



HAL
open science

Analyse stochastique des réseaux spatiaux.

Charles Bordenave

► **To cite this version:**

Charles Bordenave. Analyse stochastique des réseaux spatiaux.. Analyse fonctionnelle [math.FA]. Ecole Polytechnique X, 2006. Français. NNT: . pastel-00001902

HAL Id: pastel-00001902

<https://pastel.hal.science/pastel-00001902>

Submitted on 28 Jul 2010

HAL is a multi-disciplinary open access archive for the deposit and dissemination of scientific research documents, whether they are published or not. The documents may come from teaching and research institutions in France or abroad, or from public or private research centers.

L'archive ouverte pluridisciplinaire **HAL**, est destinée au dépôt et à la diffusion de documents scientifiques de niveau recherche, publiés ou non, émanant des établissements d'enseignement et de recherche français ou étrangers, des laboratoires publics ou privés.

THÈSE

Analyse Stochastique des Réseaux Spatiaux

présentée pour obtenir le titre de

Docteur de l'Ecole Polytechnique
spécialité : Mathématiques Appliquées

par Charles BORDENAVE

soutenue le 4 Juillet 2006, devant le jury composé de:

Messieurs	David ALDOUS	Rapporteur
	Nicholas BAMBOS	Rapporteur
	Jean-François LE GALL	Président
	Sergei FOSS	Examineur
	René SCHOTT	Examineur
	François BACCELLI	Directeur de Thèse

Remerciements / *Acknowledgements*

Ces remerciements sont tout d'abord une occasion pour moi d'exprimer ma profonde reconnaissance à François Baccelli. Sa créativité, sa rigueur scientifique et ses conseils m'ont guidé tout au long de ces trois années et ont été déterminants dans mon parcours en thèse et ses suites. Ce fut un plaisir et un honneur de découvrir la recherche sous sa bienveillante direction.

Je tiens à remercier David Aldous et Nick Bambos d'avoir accepté de lire et de rapporter ce travail. Je remercie vivement Jean-François Le Gall et René Schott d'avoir accepté de participer à mon jury de thèse. C'est un honneur pour moi d'être examiné par ses chercheurs exceptionnels.

Je remercie également Sergei Foss d'avoir accepté d'être membre du jury et pour notre longue et amicale collaboration académique. J'ai énormément appris à ses côtés et cela a été un plaisir de travailler avec lui.

Je suis très redevable à mes autres co-auteurs, Yann Gousseau, David McDonald, Marc Lelarge, Alexandre Proutière, François Roueff, Seva Vsevolod et Gian Luca Torrisi. Cette thèse a bénéficié grandement de leurs talents et de leurs connaissances académiques.

Je souhaite remercier Neil O'Connell pour ses conseils scientifiques toujours fructueux et pour le trimestre très intéressant que j'ai passé au Centre Boole de l'University College Cork.

Je tiens à remercier tous les collègues du projet TREC et du Research Lab 1 du Centre Boole, pour leurs conseils avisés, pour l'ambiance studieuse et amicale qu'ils ont su entretenir et pour toutes ces discussions éclairantes autour d'un tableau. Je remercie tout particulièrement Bartek Blaszczyszyn pour sa disponibilité exceptionnelle, et pour les bons moments passés ensemble, Thomas Bonald, Pierre Brémaud, Giovanna Carofiglo, Augustin Chaintreau, Prassana Chaporkar, Yogesh Dandhapani, Andrew Haugh, Connell Kelly, Ki-Baek Kim, Tony Metcalfe, John Moriarty, Marta Piancino, Bozidar Radunovic, Julien Reynier, Emmanuel Roy, Artyom Sapozhnikov et Minh-Anh Tran.

Je suis reconnaissant à l'INRIA et à l'École Normale Supérieure pour m'avoir donné les moyens de travailler. Je remercie également Yves Meyer et Eric Moulines pour leurs conseils bienveillants dans mes orientations universitaires et professionnelles. Je remercie Florence Barbara, Joelle Isnard, Helen Joustra, Laurence Lenormand et Valérie Mongiat pour leur gentillesse et leur aide dans les tâches administratives.

Enfin, je n'aurais pas pu venir à bout de ce travail académique sans le soutien non-académique de mes proches. Mille et un merci à Najda Laroussi.

Contents

Remerciements/ Acknowledgements	i
Introduction	ix
Part I : Geometric spanning trees	ix
Part II : Spatial random access networks	x
Part III : Spatial point processes	xi
Contributions	xii
I Geometric Spanning Trees	1
1 Navigation on a Poisson point process	3
1.1 Introduction	4
1.1.1 Navigation: definition and perspective	4
1.1.2 Directed Navigation	5
1.1.3 Navigation Tree and Navigation Graph	6
1.1.4 Poisson Point Process and Poisson Weighted Infinite Tree	6
1.1.5 Examples	7
1.1.6 Overview of the Results	9
1.1.7 Notations and Preliminaries	13
1.2 Convergence of navigation to directed navigation	13
1.2.1 Stable Functionals and Local Weak Convergence	13
1.2.2 Sketch of Application: Spatial Average	16
1.2.3 Example: Progress Distribution in the Small World	17
1.3 Path average for memoryless navigation	20
1.3.1 Finite Mean Progress	20
1.3.2 α -Stable Model	25
1.3.3 Relatively Stable Model	26
1.3.4 Scaled Progress	26
1.3.5 Average along a Path	28
1.4 Path Average for Navigation	29
1.4.1 Path Average for Regenerative Navigation	29
1.4.2 Directed Navigation on the Discrete Lattice Small World	29
1.4.3 Directed Navigation on a Small World	32
1.4.4 Navigation in a Small World	35
1.4.5 Decentralized Navigation	40
1.5 Navigation Tree Topology	43
1.5.1 Maximal Deviation, Tree topology and f -straightness	43
1.5.2 Memoryless Isotropic navigation	45
1.5.3 Proof of Theorem 1.5.5	46

1.5.4	Isotropic Regenerative Navigation	50
1.6	Shape of the Navigation Tree	51
1.6.1	Shape of Memoryless Navigation	51
1.6.2	Proof of Theorem 1.6.2 and Proposition 1.6.3	53
1.6.3	Shape of Regenerative Navigation	54
1.7	Miscellaneous	56
1.7.1	Further examples of navigation	56
1.7.2	Collection of technical Lemmas	57
1.7.3	A few results of Renewal Theory	59
2	The Radial Spanning Tree of a Poisson Point Process	61
2.1	Introduction	62
2.2	The Radial Spanning Tree	62
2.2.1	Definition	62
2.2.2	Notation	63
2.2.3	Summary of Results	64
2.3	Local Properties of the Radial Spanning Tree	65
2.3.1	Distribution of the Length of Edges	65
2.3.2	Edge Distribution	67
2.3.3	Mean Degree of a Vertex	67
2.3.4	Limit Distribution of an Edge Length	69
2.3.5	Expectation of the Number of Crossing Edges	70
2.3.6	Proof of Theorem 2.2.3	70
2.4	The Directed Path	71
2.4.1	The Underlying Markov Chain	72
2.4.2	Limit Theorems	78
2.4.3	Maximal Deviation	80
2.5	The Radial Path	80
2.5.1	Maximal Deviation of the Radial Path	81
2.5.2	Law of Large Numbers on the Radial Path	83
2.5.3	Shape of the RST	85
2.6	Spatial Averages of Edge Lengths	86
2.7	Model Extension and Open Problems	89
2.7.1	Greedy Forests	89
2.7.2	The Radial Spanning Tree of a Voronoi Cell	89
2.7.3	Some open problems	91
3	Minimal Spanning Tree and Scaling Relations	93
3.1	Introduction	94
3.2	Main steps of the proof	95
3.3	Continuum percolation far from critical radius	97
3.3.1	Proof of Lemma 3.2.1	97
3.3.2	Proof of (3.3)	98
3.3.3	Proof of Lemma 3.2.2	98
3.4	Proof of Lemma 3.2.3	99
3.4.1	Proof of Lemma 3.4.3	102
3.5	A comment on critical exponents and minimal spanning tree	103

II	Spatial Random Access Networks	105
4	Mean Field analysis	107
4.1	Introduction	108
4.2	Random back-off algorithms	109
4.3	Convergence theorems	110
4.3.1	Transient behavior	110
4.3.2	Stationary regimes	110
4.4	Proof of Theorems 4.3.1 and 4.3.2	111
4.4.1	Proof of Theorems 4.3.1 and 4.3.2	111
4.4.2	Proof of Theorem 4.3.4	115
5	A Random Access Protocol with Spatial Interactions	117
5.1	Introduction and the main result	118
5.1.1	A spatial Aloha	118
5.1.2	Model Description	118
5.1.3	Main result	120
5.2	Fluid Approximation Method	121
5.2.1	General Properties	121
5.2.2	Fluid model criterion for stability	122
5.2.3	Fluid Limit Evolution Equation	122
5.3	Properties of the Fluid Limit on the Boundary	125
5.4	Proof of Theorem 5.1.1	128
5.5	Rates of Convergence	130
5.6	Local Stability of Fluid Limits on the positive Orthant	132
5.6.1	Orbits of the fluid limits	132
5.6.2	Proof of Theorem 5.6.2	133
5.7	Extensions of the model	136
5.7.1	Random neighbourhood	136
5.7.2	Non-regular graphs with space-inhomogeneous input	137
5.7.3	Infinite Graph	137
5.7.4	Continuous Model	137
5.7.5	Shot-noise Interaction	137
6	Stability of spatial queueing systems	139
6.1	Introduction: Model description	140
6.1.1	Customers arrival point process	140
6.1.2	Server stations policy	141
6.1.3	Evolution Equation	142
6.1.4	Some Examples	142
6.2	Stability Analysis	142
6.2.1	Stability Region	142
6.2.2	Necessity for stability of Theorem 6.2.1	143
6.2.3	Sufficiency for stability of Theorem 6.2.1	144
6.2.4	Convergence toward a Stationary Solution	147
6.3	Monotone cone policies	147
6.3.1	Loynes' sequence for Monotone policies	147
6.3.2	Stability of cone policies and saturation rule	149
6.4	Spatial Allocation	151
6.4.1	Optimal Spatial Allocation	151

6.4.2	Cellular Policies	153
6.4.3	Homogeneous Networks	154
7	Spatial Capacity of Wireless Networks	157
7.1	Introduction	158
7.2	Uplink	159
7.2.1	Model description	159
7.2.2	Stochastic Model	160
7.2.3	Proof of Theorem 7.2.3	162
7.3	Downlink	166
7.3.1	Model Description	166
7.3.2	Power Allocation Algebras	167
7.3.3	Optimal Power Allocation	168
7.3.4	Proof of Theorem 7.3.5	169
7.3.5	Asymptotic Load	171
7.3.6	Proof of Theorem 7.3.10	173
7.3.7	Infinite Networks	174
7.4	Dynamic Model on the Downlink	176
7.4.1	User Arrival Process	176
7.4.2	Base Station Adaptive Policy	177
7.4.3	Canonical Example	178
7.4.4	Slow Fading and Mobility	179
III	Spatial Point Process	181
8	The dead leaves model	183
8.1	Introduction	184
8.2	Basic definitions	185
8.2.1	Closed Sets and Tessellations	185
8.2.2	Typical Cell distribution	186
8.3	The dead leaves model	187
8.3.1	Definition	187
8.3.2	Perfect simulation	189
8.3.3	Regularity properties of visible parts	189
8.4	Some characteristics of the dead leaves tessellation	190
8.4.1	Inclusion probabilities and boundary distribution	190
8.4.2	Typical relief cells	194
8.4.3	Cells intersected with a line	195
9	Monte Carlo methods for sensitivity analysis	197
9.1	Introduction	198
9.2	Preliminaries	199
9.2.1	Some notations	199
9.2.2	Analyticity and differentiability of functionals of Poisson processes	199
9.3	Rare perturbation analysis	201
9.3.1	Rare Perturbation Analysis of monotone functionals: the first order derivative	201
9.3.2	Higher order derivatives	205
9.4	Applications	211

9.4.1	Stable functionals in geometric probability	211
9.4.2	Poisson shot noise processes	211
9.4.3	Sensitivity analysis of stochastic systems described by Poisson shot noise processes	212
9.4.4	Compound Poisson processes	216
9.4.5	Optimal estimators for sensitivity analysis in the compound Poisson case	217
9.5	A Numerical Illustration	218

Appendix		221
A	The Coupling Method	221
	A.1 The Coupling Inequality	221
	A.2 Stochastic Domination	221
B	Point processes	222
	B.1 Vague convergence of locally finite measures	222
	B.2 Stationary Point Process and Palm Theory	222
	B.3 Poisson point processes and Slivnyak-Campbell Formula	224
C	Queueing Theory	225
	C.1 Loynes' Sequence for stochastic recurrences	225
	C.2 Tail Inequality in the GI/GI/ ∞	226
D	A spatial network paradigm	229

Introduction

This thesis is divided into three parts. They are independent and can be read separately. This short introduction aims at summarizing briefly the theme of each part.

Part I : Geometric spanning trees

Random graph theory has started with the celebrated work of Erdős and Rényi in the sixties. In their work, the distribution of the edges of the graph is independent and uniformly distributed on the set of pairs of vertices.

A geometric graph is a graph where the vertices are points scattered in some metric space and where the set of edges depends on the relative positions of the vertices. As an alternative of Erdős and Rényi theory, in geometric graphs, the randomness is based on the randomness of the vertex set and not anymore on the edges. The independence of the edges is often replaced by the hypothesis that the set of vertices is a Poisson point process, or in a discrete version, a regular grid with independent thinning.

This conceptual difference has an impact on the mathematical tools developed to analyze these fundamental structures. For example, the connectedness of a geometric random graphs is percolation theory, and the distribution of the neighbors of a vertex is computed thanks to stochastic geometry.

We can distinguish two classes of geometric graphs. A first class contains the graphs such that the set of neighbors of a vertex is determined thanks to the local configuration of the vertex set. For example, the graph associated to the Boolean model is built by putting an edge between two points if their distance is less than some radius R (which can be random or deterministic). Another famous example is the Delaunay triangulation. There is an edge between two vertices if there exists a closed ball containing the two vertices but no other vertices. We will refer to this graph as self-organizing graphs since only few geometrical information are needed to build the neighbors of a vertex.

The graphs obtained through a combinatorial optimization belong to the second class of geometric graphs. These graphs minimize a global functional, and the geometric information they use are therefore much more sophisticated. When the vertex set is an infinite number of points, the mere existence of these graphs is a non-trivial question. On a finite number of vertices, a celebrated example is the traveling salesman problem, that is the shortest self-avoiding path containing all vertices. Another fundamental example is the minimal spanning tree which is the tree containing all vertices and with the shortest total edge length.

In the first part of this thesis, the attention is focused on the properties of paths through random points. We fix a distinguished vertex, taken as the origin. On a connected graph, from

any vertex, there exists a family of paths leading to the origin. In first passage percolation, we examine the properties of the path minimizing the total edge length. Similarly, a path in the minimal spanning tree minimizes the maximum of the length of the edges on the path. These paths are thus obtained via an optimization procedure. There exist also self-organizing methods of selecting a path inside the family of paths leading to the origin. In this case the path is built iteratively. A simple example is as follows, in the Delaunay triangulation, at each vertex, the next vertex on the path is the neighboring vertex with has the closest direction with the origin (compass routing).

The set of paths leading to the origin builds a spanning tree of the vertex set. In Chapter 1, this tree is called the navigation tree, and we will analyze the properties of the self-organizing navigation trees. We examine the convergence of these navigation trees for the local weak convergence toward a limit forest. Our main effort will be done on the number of edges in the path leading a vertex to the origin, when this vertex is far from the origin. We will derive various asymptotic results depending on the nature of the graph. The analysis of the deviation of this path will lead us to characterize the semi-infinite self-avoiding paths of the navigation trees.

In Chapter 2 we focus our attention on the particular example of a self-organizing tree, the radial spanning tree. On this specific example, we will present also alternative proofs of the results obtained in the previous chapter. We will also use stochastic geometry tools to compute the distribution of an edge and the mean degree of a vertex.

In Chapter 3, we examine the path between two vertices in the minimal spanning tree. In order to answer a question of Aldous, we will analyze the maximal edge length in the path. This will lead us to relate some properties of the minimal spanning tree with the scaling relations in percolation.

We cannot conclude the presentation of the first part of this thesis without mentioning some applications of spanning trees in communication networks. This field of application was already present in the pioneering work of Erdős and Rényi. The vertices represent users in a network and the communication between users are performed through a path in the connection graph associated to the network. The understanding of the properties of the paths on the graph is of prime interest. The analysis of the paths obtained via a combinatorial optimization gives the best achievable bounds on the behavior of the network. For example, the flooding of the network is described by first passage percolation. Self-organizing graphs and paths have also found a new field of application with the development of large self-organized networks, such as peer to peer overlay networks or ad-hoc wireless networks. In this context, the mathematical analysis may have two major contributions: the performance analysis of current structures and the design of new networks more adapted to large scale.

Part II : Spatial random access networks

The development of wireless networks has created a variety of new problems for mathematicians. Among them, new problems are emerging in the field the stability of stochastic processes. The second part of this thesis is devoted to the stability analysis of random access protocols where a spatial interaction between the users in the system is taken into account.

In a spatial network, some sources receive or send information through a common channel. The foundations of wireless communication are given by the information theory. It is not in the scope of this thesis to explore this field, however we can point out two main features of spatial networks:

- the sources behave independently: they only share information through the common channel.

- the common channel has a spatial reuse property: two sources far away may access the channel at the same time.

Section D in Appendix is an attempt to define a general paradigm for a wide class of problems in spatial networks.

The architecture of spatial networks falls into two categories: coordinated and non-coordinated networks. In a coordinated network, there exists a set of base stations which may enforce a control policy to optimize the performance of the system. A cellular network is an example of such system. The sources are mobile users and the base stations control the access. In a non-coordinated network, there is not this hierarchical structure. The sources are left to their own and the effect of interference is not anymore tempered by a coordinated access policy. The analysis of these two category differs significantly.

Another criterion of classification relies on the probabilistic model used. The sources may be saturated or not saturated. A source is saturated if it is always present in the network: the sources have always information to send or receive. A natural question is then to understand the behavior of the network when the number of sources grows large. If the sources are not saturated, a source leaves the network when its piece of information has been received or sent. The network is filled by an arrival process of sources and a fundamental question is the stability of the system.

In Chapter 4, the sources are saturated and non-coordinated. We perform a mean-field analysis of random access protocols with exponential back-off. In particular, we prove that, as their number grows large, the sources become independent from each other. In the limit, we establish that the distribution of back-offs satisfies a differential equation.

In Chapter 5, the sources are non-coordinated and non-saturated. We present a model which captures the spatial reuse property of spatial networks. This model may be thought as a spatial version of an aloha protocol. The stability of the workload is examined. We prove that the workload properly scaled converges to its fluid limits, and we examine the differential equation satisfied by the fluid limits.

In Chapter 6, the sources are non-saturated and coordinated. We examine the stability region of a queueing system where the processing rates of the servers depend on the position of the users.

Finally, in Chapter 7, the sources are saturated and coordinated. We examine the properties of the system when the sources are distributed according to an ergodic point process on the plane.

In summary, the chapters of the second part of this thesis may be classified as follows:

	non-saturated	saturated
non-coordinated	chapter 5	chapter 4
coordinated	chapter 7	chapter 6

Part III : Spatial point processes

Point processes, used as background material in the first two parts of this thesis, are the core of the Chapters 8 and 9.

In Chapter 8, we examine the dead leaves tessellation. This model of stochastic geometry has been introduced by Matheron. We review and extend known results in the unifying framework of Palm distribution.

In Chapter 9, we derive a Monte Carlo method to simulate the derivatives of the expectation of functionals of a marked Poisson point process. The Monte Carlo simulation is based on new formulas for these derivatives. This method finds some application in geometric probability, and in the level crossing probability of Poisson shot-noise processes.

Contributions

This thesis is the result of a common work with some fellows. Each collaboration has been a great learning opportunity with these brilliant scientists.

Chapters 1 and 2 are the fruits of a joint work with François Baccelli. Chapter 1 is based on [36] and Chapter 2 on [16] and [17].

Chapter 3 is a collaboration with Marc Lelarge on a problem raised by David Aldous and pointed to us by Neil O’Connell.

Chapter 4 is a joint work with David Mac Donald and Alexandre Proutière. The corresponding paper is [39].

Chapter 5 is a long collaboration with Sergei Foss and Seva Vsevolod. This unusual work has not come to an end yet.

Chapters 6 and 7 have benefitted from discussions with François Baccelli and Bartłomiej Błaszczyszyn. Paragraph §6.3.2 is the beginning of a work with Marc Lelarge. Apart, from this paragraph, Chapter 6 is based on [38] and Chapter 7 on [37] and on the research report [35].

Chapter 8 is a joint work with Yann Gousseau and François Roueff, this chapter is contained in [40].

Finally, Chapter 9 is a collaboration with Giovanni Luca Torrisi. It is a slight extension of [41].

Part I

Geometric Spanning Trees

Chapter 1

Navigation on a Poisson point process

Résumé Sur un ensemble de points localement fini, une navigation construit un chemin sur cet ensemble qui relie un point à un autre. L'ensemble des chemins aboutissant à un point donné définit un arbre : l'arbre de navigation. Dans ce article, nous étudions les propriétés de l'arbre de navigation lorsque l'ensemble de points est un processus ponctuel de Poisson sur \mathbb{R}^d . Nous examinons la distribution de fonctionnelles stables, la convergence faible locale de l'arbre de navigation, la moyenne asymptotique d'une fonctionnelle le long d'un chemin, la forme de l'arbre de navigation et ses fins topologiques. Nous illustrons notre travail sur les graphes de type "small world" et nous y établissons de nouveaux résultats. Ce travail est motivé par des applications en géométrie computationnelle et dans les réseaux auto-organisés.

Abstract On a locally finite point set, a navigation defines a path through the point set from a point to an other. The set of paths leading to a given point defines a tree, the navigation tree. In this article, we analyze the properties of the navigation tree when the point set is a Poisson point process on \mathbb{R}^d . We examine the distribution of stable functionals, the local weak convergence of the navigation tree, the asymptotic average of a functional along a path, the shape of the navigation tree and its topological ends. We illustrate our work in the small world graphs, and new results are established. This work is motivated by applications in computational geometry and in self-organizing networks.

1.1 Introduction

1.1.1 Navigation: definition and perspective

In this chapter, we examine decentralized navigation algorithms on random graphs. Let N be a locally finite point set and O a point in \mathbb{R}^d taken as the origin sometimes denoted by 0. For $x, y \in \mathbb{R}^d$, $|x|$ will denote the Euclidian norm and $\langle x, y \rangle$ the usual scalar product. $B(X, r)$ is the open ball of radius r and center x , and $S^{d-1} = \{x \in \mathbb{R}^d : |x| = 1\}$ is the d -dimensional hyper-sphere.

Definition 1.1.1 *Assume that $O \in N$, a navigation (with root O) is a mapping \mathcal{A} from N to N such that for all X in N there exists a finite k satisfying $\mathcal{A}^k(X) = O$. A navigation on a graph $\mathcal{G} = (N, E)$ is a navigation such that $(X, \mathcal{A}(X)) \in E$.*

With a navigation with root O , we can define a navigation with root Y by $\mathcal{A}_Y(X; N) = Y + \mathcal{A}(X - Y; S_{-Y} \circ N)$ where S_x is the translation by x : if $B \subset \mathbb{R}^d$, $S_x B = \{y : y - x \in B\}$.

In this chapter we will analyze the *decentralized navigation* algorithms. For a navigation defined on a graph \mathcal{G} , a decentralized navigation is such that $\mathcal{A}_Y(X)$ depends only on X, Y and the set of vertices adjacent to X in \mathcal{G} . A navigation is always decentralized on the complete graph, so the meaning of this definition is unclear and it is not intrinsic to \mathcal{A} , we will give later a better definition.

Navigation algorithms have emerged recently in papers in four different classes of problems (at least). A first class of problem which has recently drawn much attention is the small world phenomenon. As it is pointed by Kleinberg [104], the small world phenomenon relies on the existence of shortcuts in a decentralized navigation on a small world graph. Extension and refinements of his results have been carried out by Franceschetti and Meester [68], Ganesh et al. [70], [59].

A second field of application is computational geometry. Kranakis, Singh and Urrutia [110] have introduced the compass routing (some numerous variants exist). The Ph.D. Thesis of Morin [127] gives a review of this class of problems. Computer scientists do not analyze the probabilistic properties of navigation algorithms, they rather examine if a given algorithm is a proper navigation, that is if it converges in a finite number of hops to its root.

The ideas of computational geometry may benefit the design of real world networks. A first field of application is sensor and ad-hoc networks, see for example the survey papers of Akyildiz et al. [2] and Ko and Vaidya [108]. A second application is self-organized overlay and peer-to-peer networks. Each node in the network receives a virtual coordinate in some naming space, and the messages are routed along a geometric navigation algorithm, see Plaxton, Rajaraman and Richa [135], Liebeherr, Nahas and Si [114] or Kermarrec, Massoulié and Ganesh [69].

Lastly, in the probabilistic literature a few authors have examined decentralized navigation algorithms (under other names). Baccelli, Tchoumatchenko and Zuyev [23] have analyzed a navigation on the Delaunay graph. Others examples include the Poisson Forest of Ferrari, Landim and Thorisson [64] and the Directed Spanning Forest introduced by Gangopadhyay Roy and Sarkar [71] (see also Penrose and Wade [131] and Chapter 2).

The aim of the present work is to find a unified approach to these problems.

We give three canonical examples of navigation. Among those three, only the last will draw our attention. These examples are nevertheless useful to understand the context better.

A natural navigation is the *shortest path* on a connected graph $\mathcal{G} = (N, E)$. Let g be a functional on E (g is a cost function) and let $\Pi(X, Y)$ denote the set of paths in \mathcal{G} from X to Y , i.e. the finite sequences of vertices in N (X_0, \dots, X_k) such that $X_0 = X$, $(X_i, X_{i+1}) \in E$

$0 \leq i \leq k-1$ and $X_k = Y$. Provided that it is uniquely defined the shortest path is

$$\pi^*(X, Y) = \arg \inf_{(X_0, \dots, X_k) \in \Pi(X, Y)} \sum_{i=0}^{k-1} g(X_i, X_{i+1}).$$

If $\pi^*(X, Y) = (X_0^*, \dots, X_k^*)$, the shortest path navigation is: $\mathcal{A}_Y^*(X) = X_1^*$. For $g = 1$, the shortest path is the path which minimizes the number of hops from X to Y in \mathcal{G} : it corresponds to the graph distance between X and Y . Shortest paths on specific graphs have drawn much attention. In particular Vahidi-Asl and Wierman ([155],[156]) have studied the shortest path on the Delaunay graph of a Poisson point process for $g = 1$, see also Pimentel [134]. On the complete graph of a Poisson point process and $g(X, Y) = |X - Y|^\beta, \beta > 2$ an in-depth analysis was performed by Howard and Newman in [93]. The shortest path is the continuum analog of the celebrated *first passage percolation* on the regular \mathbb{Z}^d -lattice. The shortest path navigation has poor decentralization properties, nevertheless it gives the best achievable performance of a decentralized navigation.

A *random walk* on \mathcal{G} is a decentralized navigation provided that the random walk is recurrent: the length of the path is the hitting time of Y starting from X . In the recurrent case, this hitting time is almost surely finite for all pairs (X, Y) . However, on an infinite graph, even in the recurrent case, one might expect that the walk is null recurrent: the expectation of the length is infinite. Therefore random walks will not provide interesting navigation algorithms. More efficient decentralized navigation algorithms exist.

An important decentralized navigation is the *maximal progress navigation*. If \mathcal{A} is a navigation, the progress is defined as:

$$P(X) = |X| - |\mathcal{A}(X)|.$$

An appealing class of decentralized navigation is the subclass of navigation such that the progress is non-negative for all X . On a graph $\mathcal{G} = (N, E)$, the maximal progress navigation is the navigation which maximizes the progress: $\mathcal{A}(X) = Y$ if $(X, Y) \in E$ and $|Y|$ is minimal. Note that the maximal progress navigation will not be a proper navigation on all graphs, some additional properties on the graph (or on the point set) have to be added. Some breaking ties rules should also be defined to guarantee the uniqueness of this navigation.

1.1.2 Directed Navigation

A navigation links a point X to another Y . When X is far from Y , the progress made is roughly equal to $\langle X - \mathcal{A}_Y(X), X - Y \rangle / |X - Y|$ that is the progress made along an axis with direction $Y - X$. Hence in most circumstances, we expect that a navigation behaves asymptotically as a *directed navigation*. Let $e_1 \in S^{d-1}$, a directed navigation with direction e_1 is a mapping \mathcal{A}_{e_1} from N to N such that for all X in N , $\lim_k \langle \mathcal{A}_{e_1}^k(X), e_1 \rangle = +\infty$. On a graph $\mathcal{G} = (N, E)$, a directed navigation is a directed navigation such that for all $X \in N$, $(X, \mathcal{A}_{e_1}(X)) \in E$.

As pointed above, directed navigation will appear as natural limiting objects for navigation. We will actually see later what type of convergence has to be considered.

The *directed progress* is defined as:

$$P_{e_1}(X) = \langle \mathcal{A}_{e_1}(X), e_1 \rangle - \langle X, e_1 \rangle.$$

A few examples of decentralized directed navigation may be found in the literature: directed path on the Delaunay tessellation [23], the Poisson forest [64], the directed spanning forest [71], [131].

On a graph, we also define the *maximal directed progress navigation* as the navigation which maximizes the directed progress. The maximal directed progress navigation is the limit mapping of the maximal progress navigation.

1.1.3 Navigation Tree and Navigation Graph

Assume that $O \in N$, a navigation \mathcal{A} to the origin O defines a graph: the *navigation tree* which will be denoted by $\mathcal{T}_0 = (N, E_0)$. It is defined by

$$(X, Y) \in E_0 \text{ if } \mathcal{A}(X) = Y \text{ or } \mathcal{A}(Y) = X.$$

It is easily checked that \mathcal{T}_0 is actually a tree: if there were a loop it would be contradictory with the assumption that $\mathcal{A}(X)^k = O$ for k large enough. \mathcal{T}_0 is the union of all the paths from $X \in N$ to O . Note that \mathcal{T}_0 is a *spanning tree* of N .

For a directed navigation, we define similarly the *directed navigation forest*, $\mathcal{T}_{e_1} = (N, E_{e_1})$ by

$$(X, Y) \in E_{e_1} \text{ if } \mathcal{A}_{e_1}(X) = Y \text{ or } \mathcal{A}_{e_1}(Y) = X.$$

We check similarly that \mathcal{T}_{e_1} is a forest. We will prove that \mathcal{T}_{e_1} is the natural limit of \mathcal{T}_0 for the local weak convergence of Aldous and Steele [5].

Extending the navigation tree to the origin to any point of N , we can also define the *navigation graph* $\cup_{Y \in N} \mathcal{T}_Y$ and the directed navigation graph $\cup_{e_1 \in S^{d-1}} \mathcal{T}_{e_1}$. These two graphs record the set of possible navigation from one point to another (or in a direction).

We can now state an intrinsic definition for a decentralized navigation:

Definition 1.1.2 *A navigation \mathcal{A} (to the root O) is decentralized if $\mathcal{A}(X)$ depends only of X , O and the edges adjacent to X in \mathcal{T}_0 .*

With this definition a shortest path navigation is not a decentralized algorithm, whereas a maximal progress navigation is decentralized.

1.1.4 Poisson Point Process and Poisson Weighted Infinite Tree

We will pay attention to $\mathcal{A}^k(X)$ on a locally finite point set containing X and 0 , and respectively for a directed navigation, to $\mathcal{A}_{e_1}^k(0)$ where $e_1 \in S^{d-1}$ and 0 is a point of the point set. In our analysis, we will prove convergence results for two types of probabilistic models.

The first model is the usual *Poisson point process (PPP)*, N , of intensity one on \mathbb{R}^d . We will denote: $N^0 = N + \delta_0$ and $N^{0,X} = N + \delta_X + \delta_0$. From Slyvniak Theorem, N^0 (resp. $N^{0,X}$) is a PPP on its Palm version at 0 (resp. $(0, X)$) (see in Appendix §B.3). Intuitively, N^0 (resp. $N^{0,X}$) can be understood as a PPP conditioned on having an atom at 0 (resp. atoms at 0 and X). It is not a restriction to assume that the intensity of the PPP is one, with a proper rescaling, our results extend to any positive intensity. Indeed, if $N = \sum_{n \in \mathbb{N}} \delta_{T_n}$ is a realization a PPP of intensity one, then $N_\lambda = \sum_{n \in \mathbb{N}} \delta_{\lambda^{-1/d} T_n}$ is a PPP of intensity $\lambda > 0$.

The second model is the *Poisson Weighted Infinite Tree*. Following the brilliant approach of Meester and Franceschetti in [68], we will try to understand the intrinsic behavior of a navigation through a virtual model which is the simplest possible probabilistic model. To this end we build a Poisson weighted infinite tree (PWIT) which is a slight variation of Aldous' PWIT [5]. We fix a root $X \in \mathbb{R}^d$ and define the PWIT $T^{0,X}$ as follows. The points of $N^{0,X} \setminus \{X\}$ are the vertices of first generation in T^X . $T^{0,X}$ is defined iteratively at each generation: at each vertex Y the subtree rooted at Y consisting of all descendants of Y is a PWIT $T^{0,Y}$ and the Poisson point processes are drawn independently of the others. Note that there is a vertex located at 0 at each positive generation. Thus each generation has a different copy of the origin in order to guarantee that $T^{0,X}$ is indeed a tree.

For a decentralized navigation, it is important to note that the distribution of $(X, \mathcal{A}(X))$ is the same in the PWIT $T^{0,X}$ and in the PPP $N^{0,X}$. However the joint distribution of $(\mathcal{A}^k(X))_{k \in \mathbb{N}}$ is not the same in the PWIT and the PPP. It is much simpler on the PWIT.

For a directed navigation \mathcal{A}_{e_1} , let $X_k = \mathcal{A}_{e_1}^k(X)$ and $\mathcal{F}_k = \sigma\{X_0, \dots, X_k\}$. A key feature of the PWIT is the relation

$$\mathbb{P}(X_{k+1} - X_k \in \cdot | \mathcal{F}_k) = \mathbb{P}((0, \mathcal{A}_{e_1}(0)) \in \cdot). \quad (1.1)$$

This last property is the (*spatial*) *memoryless* property of the directed navigation on the PWIT. Similarly, for a navigation \mathcal{A} and $X_k = \mathcal{A}^k(X)$, we have:

$$\mathbb{P}(X_{k+1} \in \cdot | \mathcal{F}_k) = \mathbb{P}(X_{k+1} \in \cdot | X_k), \quad (1.2)$$

the sequence $(X_k)_{k \in \mathbb{N}}$ is a Markov chain with 0 as absorbing state. With an abuse of terminology we will call also this property the *memoryless* property of a navigation on a PWIT. More generally for a navigation on a PPP, we introduce the two following definitions which are the core of this work.

Definition 1.1.3 - A navigation \mathcal{A} is a *memoryless navigation* if Equation (1.2) holds (and respectively for a directed navigation with Equation (1.1)).

- A navigation is *regenerative* if there exists a stopping-time (on a enlarged probability space) $\theta > 0$ such that \mathcal{A}^θ is a *memoryless navigation* and the distribution of $\theta(X)$ is independent of X for $|X_\theta| \geq x_0$ (and respectively for a directed navigation).

The stopping time θ will be called a *regenerative time*. If there exists a regenerative time, there exists an increasing sequence $(\theta_n), n \in \mathbb{N}$, which we will call a *regenerative sequence* such that $\theta_0 = 0$, the distribution of $(\theta_{n+1} - \theta_n)_{n \in \mathbb{N}}$ is iid and for $|X_{\theta_n}| \geq x_0$

$$\mathbb{P}(X_{\theta_{n+1}} \in \cdot | \mathcal{F}_{\theta_n}) = \mathbb{P}(X_{\theta_{n+1}} \in \cdot | X_{\theta_n}).$$

Respectively for a directed navigation, we will have $\theta_0 = 0$, the distribution of $(\theta_{n+1} - \theta_n)_n$ is iid and

$$\mathbb{P}(X_{\theta_{n+1}} - X_{\theta_n} \in \cdot | \mathcal{F}_{\theta_n}) = \mathbb{P}(X_{\theta_1} - X_0 \in \cdot).$$

A *memoryless navigation* will be much simpler to analyze. We will prove under some assumptions that a navigation on a PPP will contain a regenerative sequence, that is an embedded *memoryless navigation*. This idea is the cornerstone of this work.

All the examples of navigation algorithms we have in mind satisfy the following property:

$$\mathcal{A}(X) \text{ is } \mathcal{F}_{B(0, |X|)}^N \text{-measurable,}$$

where for a Borel set B , \mathcal{F}_B^N is the smallest σ -algebra such that the point set $N \cap B$ is measurable. A sufficient condition for this type of navigation to be *memoryless* is that for all $t \in \mathbb{N}$ and all Borel sets A :

$$\text{If } A \subset B(0, |X_k|) \text{ then } \mathbb{P}(N(A) = t | \mathcal{F}_k) = \mathbb{P}(N(A) = t), \quad (1.3)$$

in other word, $N \cap B(0, |X_k|)$ is a PPP of intensity 1.

1.1.5 Examples

Small world graphs

The *small world graph* is a graph $\mathcal{G} = (N^0, E)$ such that vertices $X \in N^0$ and $Y \in N^0$ are connected with probability $f(|X - Y|)$ independently of the other, and f is a non-increasing function with value in $[0, 1]$. We assume, as t tends to infinity, that:

$$f(t) \sim ct^{-\beta},$$

with $c > 0$ and $\beta > 0$. More formally, we add marks to N to obtain a marked point process: $\overline{N} = \sum_n \delta_{X_n, V_n}$, where $V_n = (V_{nm})_{m \in \mathbb{N}} \in [0, 1]^{\mathbb{N}}$ is independent of the collection N , $(V_{nm})_{m < n}$ is an iid sequence of uniform random variables on $[0, 1]$, $V_{nn} = 1$ and $V_{nm} = V_{mn}$. For X, Y in N , we will write $V(X, Y)$ for V_{nm} where n and m are the index of X and Y . The small world graph is defined by:

$$(X, Y) \in E \text{ if } V(X, Y) \leq f(|X - Y|).$$

Note that the degree of a vertex in the small world graph could not be infinite for small choices of β (indeed for $\beta \leq d$). The maximal progress navigation from $X \in N^0$ to 0 is defined as:

$$\mathcal{A}(X) = \arg \min\{|Y| : (X, Y) \in E\}.$$

As such, the small world graph has isolated points and navigation is ill-defined on non-connected graphs. To circumvent this difficulty three possibilities arise:

1. We enlarge slightly E to ensure a positive progress for $X \in N$. This is the approach followed by Ganesh et al. in [70], [59].
2. The marks V are not anymore independent of N , they are conditioned on the event that a positive progress is feasible at any point X of N .
3. Loops are allowed and the model is unchanged but if $\mathcal{A}(X) = X$ then a new set of neighbors for $X = \mathcal{A}(X)$ is drawn independently of everything else.

We will focus on model 2, models 1 and 3 will also be discussed. The directed navigation with direction e_1 is defined similarly,

$$\mathcal{A}_{e_1}(X) = \arg \max\{\langle Y, e_1 \rangle : (X, Y) \in E^0\}.$$

Let $\mathcal{H}_{e_1}(x) = \{y \in \mathbb{R}^d : \langle y, e_1 \rangle > \langle x, e_1 \rangle\}$, the directed navigation to be properly defined if the set of neighbors of X in \mathcal{H}_{e_1} are a.s. finite (that is $\beta > d$).

Compass Routing on Delaunay Graph

Compass Routing and its numerous variants is a popular navigation in computer science. It was introduced by Kranakis et al. in [110], see also Morin [127]. Let $\mathcal{G} = (N^0, E)$ denote a locally finite connected graph. Compass routing on \mathcal{G} to 0 is a navigation defined by

$$\mathcal{A}(X) = \arg \max\{\langle \frac{X}{|X|}, \frac{X - Y}{|X - Y|} \rangle : (X, Y) \in E\},$$

In words: $\mathcal{A}(X)$ is the neighboring point of X in \mathcal{G} which is the closest in direction to the straight line $\overline{0X}$. Compass routing is not a proper navigation on any graph, a variant of this routing called Face Routing is a proper navigation. As it is pointed by Liebeherr et al. in [114], on a Delaunay Graph Compass Routing is a proper navigation.

The associated directed navigation is naturally:

$$\mathcal{A}_{e_1}(X) = \arg \max\{\langle e_1, \frac{X - Y}{|X - Y|} \rangle : (X, Y) \in E\},$$

i.e. the direction of $(X, \mathcal{A}(X, e_1))$ is the closest from e_1 . The algorithm in Baccelli et al. [23] is closely related (but not equivalent).

Radial Navigation

For $X, Y \in N^0$, $X \neq 0$, $|Y| < |X|$ it is defined as:

$$\mathcal{A}(X) = |Y| \quad \text{if} \quad N(B(X, |X - Y|) \cap B(0, |X|)) = \emptyset.$$

$\mathcal{A}(X)$ is the closest point from X which is closer from the origin. Radial navigation has an a.s. positive progress and $\mathcal{A}(X)$ is a.s. uniquely defined. The directed navigation associated to radial navigation is: if $X, Y \in N$ and $\langle Y - X, e_1 \rangle > 0$

$$\mathcal{A}_{e_1}(X) = Y \quad \text{if} \quad N(B(X, |X - Y|) \cap \mathcal{H}_{e_1}(X)) = \emptyset.$$

That is $\mathcal{A}_{e_1}(X)$ is the closest point from X which has a larger e_1 -coordinate.

The corresponding navigation tree is the radial spanning tree and it is analyzed in the next chapter. The directed spanning forest is the directed navigation forest associated with \mathcal{A}_{e_1} . This model is examined in [71], [131] and in the next chapter.

The radial navigation will be more specifically analyzed in Chapter 2.

Road Navigation

Road navigation models a car on \mathbb{R}^d starting at a point X and driving to a destination point 0. A road $R(X, e)$ is the straight line passing through X with direction $e \in S^{d-1}$. The following model has been introduced by Baccelli (private communication).

We consider a family of probability distributions on S^{d-1} , $\{\Pi_X\}$, $X \in \mathbb{R}^d$. The starting point X is on a road R_0 with random direction $e(X)$ with distribution Π_X . It drives to the closest point on R_0 of 0: the orthogonal projection of 0 on R_0 . From this new point, say X_1 , a new road R_1 starts with direction independently drawn and distribution Π_{X_1} . The driver goes to X_2 , the closest point on R_1 of 0 and so on until it finally reaches its destination (if he ever does).

Note that if $\Pi_X(X^\perp) = 0$, where $X^\perp = \{e \in S^{d-1} : \langle e, X \rangle = 0\}$ then the road navigation has an a.s. positive progress. To be sure that the driver will finally manage to reach its destination we have to assume at least that there exists x_0 such that $\Pi_X(X/|X|) > 0$ for $|X| \leq x_0$.

Our work covers the particular case when the distribution $|\langle e(X), X/|X| \rangle|$ converges weakly as $|X|$ tends to infinity.

Generalizations of this model include higher dimensional roads (as hyperplanes) or even successive projections of the origin on more complex sets than straight lines. Note that adding more roads at each point and choosing the road with the best possible direction is already included in the original model. Road navigation is not really a navigation since its maps a point in \mathbb{R}^d to another point in \mathbb{R}^d . All the results presented for regular navigation also apply to road navigation. Road navigation is clearly memoryless.

Remark 1.1.4 In §1.7.1 (at the end of this chapter), two other examples of navigation are given.

1.1.6 Overview of the Results

In this paragraph, we illustrate some of the results with the small world navigation, Model 2. We will denote by

$$\pi_d = \frac{\pi^{d/2}}{\Gamma(d/2 + 1)} \quad \text{and} \quad \omega_{d-1} = \frac{2\pi^{d/2}}{\Gamma(d/2)},$$

the d -dimensional volume of $B(0, 1)$ and the d -dimensional surface area measure of S^{d-1} .

Local Weak Convergence of the Navigation Tree

In Section 1.2, we will state some general conditions under which the navigation tree converges to the directed navigation forest for the local weak convergence on graphs as defined by Aldous and Steele in [5].

For a graph $\mathcal{G} = (N, E)$, we define $S_x \circ \mathcal{G} = (S_x N, E)$ as the graph obtained by translating all vertices N by x and keeping the same edges.

As an example, on the small world graph, let $\mathcal{T}_{e_1}(N)$ denote the directed navigation forest built on the point set N and $\mathcal{T}_0(N)$ the navigation tree built on the point set N .

Proposition 1.1.5 *Assume $\beta > d$ in the small world graph. If $|X_n|$ tends to $+\infty$ and $X_n/|X_n|$ to e_1 then $S_{-X_n} \circ \mathcal{T}_0(N^{0, X_n})$ converges to $\mathcal{T}_{-e_1}(N^0)$ for the local weak convergence.*

Let $F_X(t) = \mathbb{P}(P(X) \leq t)$ be the distribution function of the progress at X , and for $\beta > d$, let $F(t) = \mathbb{P}(P_{e_1}(0) \leq t)$ denote the distribution function of the directed progress. we will also show how to compute these distributions using some basic stochastic geometry tools, we obtain the following proposition.

Proposition 1.1.6 *For the Model 3, assume $d \geq 2$, the following properties hold:*

1. *If $\beta > d$, as t goes to infinity:*

$$\bar{F}(t) \sim \frac{2c\omega_{d-2}}{\beta-d} t^{d-\beta} \int_0^{\pi/2} \cos^{\beta-d} \theta d\theta.$$

2. *If $\beta > d$, F_X converges weakly to F .*

3. *If $\beta = d$, let \tilde{F}_X be the distribution of $\tilde{P}(X) = -\ln(1-P(X)/X) \in [0, +\infty]$, \tilde{F}_X converges weakly to \tilde{F} with $\int \tilde{F}(s) ds = \tilde{\mu} \in (0, +\infty)$.*

4. *If $d-2 < \beta < d$, the distribution of $|\mathcal{A}(X)|/|X|^{1-\frac{d-\beta}{2}}$ converges weakly to a non degenerated distribution.*

The limit distribution in statements 3 and 4 is computed explicitly. For $d \geq 3$ and $0 < \beta < d-2$, the same method can be used to prove a convergence of the properly scaled progress. The computation for $d = 1$ is simpler and the same result holds with different constants. Finally this proposition implies a similar result on Model 2, in statement 1, it suffices to divide by $\mathbb{P}(P(0) = 0) = \exp(-\int_{\mathcal{H}_{e_1}(0)} f(y) dy)$ and statements 2, 3, and 4 hold without change.

Path Average

The path from X to 0 in the navigation tree \mathcal{T}_0 is given by a sequence of vertices $\pi(X) = (X_0 = X, \dots, X_{H(X)} = 0)$ where $H(X)$ is the generation of X in \mathcal{T}_0 :

$$H(X) = \inf\{k : \mathcal{A}^k(X) = 0\}.$$

Let g be a measurable function from $\mathbb{R}^d \times \mathbb{R}^d$ to \mathbb{R} , $G(0) = 0$ and

$$G(X) = \sum_{k=0}^{H(X)-1} g(X_k, X_{k+1}) = g(X, \mathcal{A}(X)) + G(\mathcal{A}(X)). \quad (1.4)$$

In Section 1.3, we will state the various convergence results that can be expected for Equation (1.4) for a memoryless navigation. This amounts to analyze a non-homogeneous renewal

process. In Section 1.4, analogous results for regenerative navigation will be obtained as corollaries.

In the PWIT model on the small world graph, Proposition 1.2.6 will imply a result on the convergence of $H(X)$ for all $\beta > d - 2$.

Proposition 1.1.7 *For the maximal progress navigation in the small world graph of the PWIT model,*

- If $\beta > d + 1$ and $\mu = \int rF(dr)$, a.s.

$$\lim_{|X| \rightarrow \infty} \frac{H(X)}{|X|} = \frac{1}{\mu}.$$

- If $\beta = d + 1$ a.s.

$$\lim_{|X| \rightarrow \infty} \frac{H(X) \ln |X|}{|X|} = \frac{1}{c}.$$

- If $\beta \in (d, d + 1)$

$$\liminf_{|X| \rightarrow \infty} \mathbb{E} \frac{H(X)}{|X|^{\beta-d}} > 0 \quad \text{and} \quad \limsup_{|X| \rightarrow \infty} \mathbb{E} \frac{H(X)}{|X|^{\beta-d}} < \infty.$$

- If $\beta = d$ and $\tilde{\mu}$ as in Proposition 1.2.6 a.s.

$$\lim_{|X| \rightarrow \infty} \frac{H(X)}{\ln |X|} = \frac{1}{\tilde{\mu}}.$$

- If $d - 2 < \beta < d$, a.s.

$$\lim_{|X| \rightarrow \infty} \frac{H(X)}{\ln \ln |X|} = -\frac{1}{\ln(1 - \frac{d-\beta}{2})}.$$

How to prove that a navigation is regenerative ?

In Section 1.4, we explain a general method to prove that a navigation algorithm is regenerative. This original method relies on geometric properties of the navigation and tail bounds in the GI/GI/ ∞ queue.

As an example, we will prove that the small world navigation on a PPP has good regenerative properties for $\beta \leq d$ and $\beta > d + 2$. Our method fails in the case $d < \beta \leq d + 2$.

Proposition 1.1.8 - If $\beta > d + 1$, \mathcal{A} is regenerative.

- If $\beta > d + 2$ there exists $\mu > 0$ such that a.s.

$$\lim_{|X| \rightarrow \infty} \frac{H(X)}{|X|} = \frac{1}{\mu}.$$

- If $\beta = d$ and $\tilde{\mu}$ as in Proposition 1.1.6 a.s.

$$\lim_{|X| \rightarrow \infty} \frac{H(X)}{\ln |X|} = \frac{1}{\tilde{\mu}}.$$

- If $d - 2 < \beta < d$, a.s.

$$\lim_{|X| \rightarrow \infty} \frac{H(X)}{\ln \ln |X|} = -\frac{1}{\ln(1 - \frac{d-\beta}{2})}.$$

This proposition implies that the *PWIT model gives the exact order of magnitude for $H(X)$* . It is also worth to mention that our method has enabled us to determine the exact asymptotic limit for $\beta \in (d - 2, d]$.

Path Deviation and Tree Topology

In Section 1.5, we examine the path from X to O in the navigation tree. For regenerative navigation algorithms, we establish an upper bound on the maximal deviation of this path with respect to the straight line \overline{OX} :

$$\Delta(X) = \max_{0 \leq k \leq H(X)} |X_k - \overline{X}_k|,$$

with $\overline{X}_k = \langle X_k, X/|X| \rangle X/|X|$ is the projection of X_k on the straight line \overline{OX} .

Using the terminology of Howard and Newman in [93], this bound will enable us to find conditions under which \mathcal{T}_0 is an f -straight tree. In particular, it will characterize the semi-infinite paths of the navigation tree.

On the small world navigation, we obtain the following proposition.

Proposition 1.1.9 *There exists $C \geq 1$, such that if $\gamma > C(d+1)/(\beta-d)$, then for some $\eta > 0$, there exists $C_1 > 0$ such that*

$$\mathbb{P}(\Delta(X) \geq |X|^\gamma) \leq C_1 |X|^{-d-\eta}.$$

and \mathcal{T}_0 is f -straight with $f(x) = |x|^{\gamma-1}$.

A bound for the constant C could be explicitly computed. We only point out that for a small world navigation on a PWIT, $C = 1$.

Shape of the Navigation Tree

Finally, in Section 1.6 we will state a shape theorem for regenerative navigation algorithms. We define

$$\mathcal{T}_0(k) = \{X \in N : \mathcal{A}^k(X) = 0\}.$$

We restrict our attention to the following case: a.s., $\lim_{|X| \rightarrow \infty} \frac{H(X)}{|X|} = \frac{1}{\mu}$, where $\mu > 0$ is the asymptotic directed mean progress. Under some additional assumptions, we will state that for all $\epsilon > 0$ there exists a.s. K such that if $k \geq K$:

$$N \cap B(0, (1-\epsilon)k\mu) \subset \mathcal{T}_0(k) \subset B(0, (1+\epsilon)k\mu),$$

and moreover a.s. and in L^1 :

$$\frac{|\mathcal{T}_0(k)|}{\pi_d k^d} \rightarrow \mu^d.$$

On the small world graph, we will obtain the following proposition.

Proposition 1.1.10 *Let μ (resp. $\tilde{\mu}$) as in Proposition 1.1.8 (resp. Proposition 1.1.6).*

- *There exists $C \geq 1$ such that if $\beta > (C+1)d + 2C$, for all $\epsilon > 0$ there exists a.s. K such that if $k \geq K$:*

$$N \cap B(0, (1-\epsilon)k\mu) \subset \mathcal{T}_0(k) \subset B(0, (1+\epsilon)k\mu).$$

Moreover a.s. and in L^1 :

$$\frac{|\mathcal{T}_0(k)|}{\pi_d k^d} \rightarrow \mu^d,$$

- *If $\beta = d$, for all $\epsilon > 0$ there exists a.s. K such that if $k \geq K$:*

$$N \cap B(0, e^{(1-\epsilon)k\tilde{\mu}}) \subset \mathcal{T}_0(k) \subset B(0, e^{(1+\epsilon)k\tilde{\mu}}).$$

Moreover a.s. and in L^1 :

$$\frac{\ln |\mathcal{T}_0(k)|}{k} \rightarrow d\tilde{\mu}.$$

- For $d - 2 < \beta < d$, let $\alpha = 1 - (d - \beta)/2$, for all $\epsilon > 0$ there exists a.s. K such that if $k \geq K$:

$$N \cap B(0, \exp(\alpha^{(1-\epsilon)k})) \subset \mathcal{T}_0(k) \subset B(0, \exp(\alpha^{(1+\epsilon)k})).$$

Moreover a.s. and in L^1 :

$$\frac{\ln \ln |\mathcal{T}_0(k)|}{k} \rightarrow \ln \alpha.$$

Again, a bound for the constant C could be computed. In the PWIT model $C = 1$.

1.1.7 Notations and Preliminaries

If not otherwise mentioned, if $x \in \mathbb{R}^d$, $|x|$ will denote the Euclidian norm and $\langle \cdot, \cdot \rangle$ the usual scalar product. $B(x, r)$ will denote the open ball of radius r and center x , $S^{d-1} = \{x \in \mathbb{R}^d : |x| = 1\}$ is the d -dimensional hyper-sphere. If A is a set, $|A|$ will denote the cardinal of A and \bar{A} the closure of this set for the underlying topology. The d -dimensional volume of $B(0, 1)$ is $\pi_d = \frac{\pi^{d/2}}{\Gamma(d/2+1)}$ and $\omega_{d-1} = \frac{2\pi^{d/2}}{\Gamma(d/2)}$, is the $d - 1$ -dimensional area of S^{d-1} . For $e_1 \in S^{d-1}$ and $X \in \mathbb{R}^d$, $\mathcal{H}_{e_1}(X) = \{Y : \langle Y - X, e_1 \rangle > 0\}$. If the choice of e_1 is not important will sometimes simply write $\mathcal{H}(X)$ instead of $\mathcal{H} - e_1(X)$. ℓ^0 is the set of measurable $\mathbb{R}_+ \rightarrow \mathbb{R}_+$ functions tending to 0 at $+\infty$.

If N is a countable set of points in \mathbb{R}^d with no accumulation points, we write for all bounded sets A : $N(A) = \sum_{x \in N} \mathbf{1}(x \in A)$. A set of points N of \mathbb{R}^d is said to be *non-equidistant* if there do not exist points x, y, z, t of N such that $\{x, y\} \neq \{z, t\}$ and $|x - y| = |z - t|$. We define a *nice* point set as a non-equidistant locally finite point set, a Poisson point process (PPP) of positive intensity is a.s. nice. It is good to note that on nice sets, the maximal progress navigation and the radial navigation are well defined.

Several qualitative results of the present paper involve constants. For the sake of clarity, we will use C_0 to denote a positive constant to be thought of as small and C_1 to denote a positive constant to be thought of as large. The exact value of C_0 and C_1 may change from one line to the other and we could for example write : $C_0/C_1 = C_0$. The important point is that C_0 and C_1 are constants that may depend on the dimension d but they will never depend on other parameters of the problem.

1.2 Convergence of navigation to directed navigation

1.2.1 Stable Functionals and Local Weak Convergence

In this paragraph we prove that under some conditions the navigation tree tends weakly to the directed navigation tree, for the local weak convergence. We consider a navigation \mathcal{A} with non-negative progress on a PPP N of intensity 1. Proving the convergence of the navigation tree is not a difficult task, provided that we use the right concepts.

We introduce an important class of functional, the *stable functionals*. This class was first introduced by Lee [113] and it was further developed by Penrose and Yukich (see for example [132], [133]); it is slightly modified here to suit to our framework.

Definition 1.2.1 Let $F(X, N)$ be a measurable function valued in a complete separable metric space. F is stable on N if for all $X \in \mathbb{R}^d$ there exists a random variable $R(X) > 0$ such that $F(X, N)$ is $\mathcal{F}_{B(X, R(X))}^N$ -measurable and $R(X)$ is stochastically upper bounded uniformly in X .

A graph $\mathcal{G} = (N, E)$ is a stable graph if for all $X \in N$, $V(X, N) = \{Y \in N : (X, Y) \in E\}$ (i.e. the set of vertices adjacent to X in \mathcal{G}) is a stable functional.

\mathcal{A} is the maximal progress navigation on a stable graph $\mathcal{G} = (N, E)$. (1.5)

This condition is still quite general since a navigation with a positive progress is always a maximal progress navigation on its associated navigation tree. We defined the maximal directed progress navigation with direction $e_1 \in S^{d-1}$ as

$$\mathcal{A}_{e_1}(X) = \arg \max\{\langle Y - X, e_1 \rangle : Y \in N, (X, Y) \in E\}.$$

Let \mathcal{G}^0 be the graph built on N^0 and \mathcal{G} the graph built on N . The navigation \mathcal{A} is defined on \mathcal{G}^0 and the directed navigation \mathcal{A}_{e_1} on \mathcal{G} .

Lemma 1.2.2 *Let $X \in \mathbb{R}^d \setminus \{0\}$ and $e_1 \in S^{d-1}$ with $\cos \theta = \langle X/|X|, e_1 \rangle$. Under the foregoing Assumption (1.5) there exists a function $\epsilon \in \ell^0$ with*

$$\mathbb{P}(\mathcal{A}(X) \neq \mathcal{A}_{-e_1}(X)) \leq \epsilon(|X|) + \epsilon(1/\theta). \quad (1.6)$$

Proof. By Equation (1.5) there exists $h \in \ell^0$ such that for all X , $\mathbb{P}(\rho(X) \geq t) \leq h(t)$, and

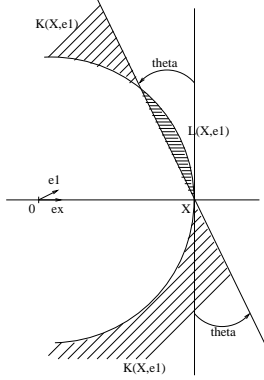

Figure 1.1: The sets $L(X, e_1)$ and $K(X, e_1)$.

$V(X, N)$ is $\mathcal{F}_{B(X, \rho(X))}^N$ -measurable. Without loss of generality we suppose $X = xe_x$, $x > 0$ and $\theta > 0$. Let $K(X, e_1) = \{Y \in \mathbb{R}^d : |Y| \geq |X|, \langle Y - X, e_1 \rangle \leq 0\}$ and $L(X, e_1) = \{Y \in \mathbb{R}^d : |Y| \leq |X|, \langle Y - X, e_1 \rangle \geq 0\}$, the sets $L(X, e_1)$ and $K(X, e_1)$ are depicted in Figure 1.1. Set $S(X) = N \cap B(X, \rho(X))$, $\tilde{\mathcal{A}}(X) = \arg \min\{|Y| : Y \in S(X)\}$ and $\tilde{\mathcal{A}}_{e_1}(X) = \arg \min\{\langle Y, e_1 \rangle : Y \in S(X)\}$. If $\rho(X) + \rho(0) < |X|$, $S(X) \cap \{K(X, e_1) \cup L(X, e_1)\} = \emptyset$ and $\tilde{\mathcal{A}}_{e_1}(X) = \tilde{\mathcal{A}}(X)$ then $\mathcal{A}_{e_1}(X) = \mathcal{A}(X)$. It follows

$$\begin{aligned} \mathbb{P}(\mathcal{A}_{-e_1}(X) \neq \mathcal{A}(X)) &\leq \mathbb{P}(\rho(X) + \rho(0) \geq |X|) + \mathbb{P}(S(X) \cap L(X, e_1) \neq \emptyset) \\ &\quad + \mathbb{P}(S(X) \cap K(X, e_1) \neq \emptyset) + \mathbb{P}(\tilde{\mathcal{A}}_{e_1}(X) \neq \tilde{\mathcal{A}}(X)). \end{aligned} \quad (1.7)$$

The first term of Equation (1.7) is easily computed : $\mathbb{P}(\rho(X) + \rho(0) \geq |X|) \leq h(|X|/2)$.

To upper bound the second term of Equation (1.7), we notice that $L(X, e_1)$ is contained in a cone of apex θ (see Figure 1.1). Let \mathcal{C}_θ be a cone issued from 0 with apex θ , we have:

$$\begin{aligned} \mathbb{P}(S(X) \cap L(X, e_1) \neq \emptyset) &\leq \mathbb{P}(N \cap \mathcal{C}_\theta \cap B(0, \theta^{-1/2}) \neq \emptyset) + \mathbb{P}(\rho(X) \geq \theta^{-1/2}) \\ &\leq 1 - \exp(-C_0 \theta^{1/2}) + h(\theta^{-1/2}). \end{aligned}$$

The third term of Equation (1.7) is upper bounded similarly. Let $K_+(X, e_1)$ be the largest half of $K(X, e_1)$; we have

$$\begin{aligned} \mathbb{P}(S(X) \cap K(X, e_1) \neq \emptyset) &\leq 2\mathbb{P}(S(X) \cap K_+(X, e_1) \neq \emptyset) \\ &\leq 2\mathbb{P}(N \cap \mathcal{C}_{\arcsin(\frac{t}{2|X|})+\theta} \cap B(0, t) \neq \emptyset) + 2\mathbb{P}(\rho(X) \geq t) \\ &\leq 2(1 - \exp(-C_0 t(\arcsin(\frac{t}{2|X|}) + \theta)) + h(t)). \end{aligned}$$

If $1/\sqrt{|X|} \leq \theta$, we choose $t = \sqrt{|X|}$ else we pick $t = 1/\sqrt{\theta}$.

It remains to bound the last term of Equation (1.7). For $Y \in B(X, \rho(X))$, let $K'(Y, X, e_1) = \{Z \in B(X, \rho(X)) : |Z| \geq |Y|, \langle Z - Y, e_1 \rangle \leq 0\}$, that is the set of points with a larger norm but a smaller projection on e_1 ; we have $K'(X, X, e_1) = K(X, e_1)$. We can then bound the last term as we have bounded the third term:

$$\begin{aligned} \mathbb{P}(\tilde{\mathcal{A}}_{e_1}(X) \neq \tilde{\mathcal{A}}(X)) &\leq \mathbb{P}(\exists Y \in S(X) : K'(Y, X, e_1) \cap N \neq \emptyset) \\ &\leq \mathbb{P}(\rho(X) \geq t) + \mathbb{P}(N(B(X, t)) \geq n) \\ &\quad + 2n\mathbb{P}(N \cap \mathcal{C}_{\arcsin(\frac{t}{2(|X|-t)})+\theta} \cap B(0, t) \neq \emptyset) \end{aligned}$$

We pick $t = \min(|X|, 1/\theta)^{1/3d}$, $n = |X|^{1/2}$, then using the inequality $\mathbb{P}(N(B(X, t)) > n) \leq \exp(-n \ln \frac{n}{C_1 t^d})$, we get the required bound. \square

Let \mathcal{T}_{e_1} denote the directed navigation forest associated to \mathcal{A}_{e_1} and \mathcal{T}_0 the navigation tree associated to \mathcal{A} . A functional is stable on a graph \mathcal{G} if it is stable on its vertex set.

Theorem 1.2.3 *Let F be a stable functional on \mathcal{T}_{-e_1} . If Equation (1.6) holds then as x tends to $+\infty$, the distribution of $F(xe_1, \mathcal{T}_0)$ converges in total variation toward the distribution of $F(0, \mathcal{T}_{-e_1})$.*

Proof. We set $X = xe_1$, $x > 0$ and we build \mathcal{T}_0 and \mathcal{T}_{-e_1} on the same PPP. For all $r > 0$, we define the event $J_t(X) = \{\mathcal{T} \cap B(X, t) = \mathcal{T}_{-e_1} \cap B(X, t)\}$. F is a stable functional on \mathcal{T}_{-e_1} for a radius $R(X)$, we have:

$$\begin{aligned} \mathbb{P}(F(X, \mathcal{T}_0) \neq F(X, \mathcal{T}_{-e_1})) &\leq \mathbb{P}(J_{R(X)}(X)^c) \\ &\leq \mathbb{P}(R(X) > t) + \mathbb{P}(J_t(X)^c) \\ &\leq \mathbb{P}(R > t) + \mathbb{P}(\cup_{Y \in N \cap B(X, t)} \mathcal{A}(Y) \neq \mathcal{A}_{-e_1}(Y)) \\ &\leq \mathbb{P}(R > t) + \mathbb{P}(N(B(X, t)) \geq n) + n\epsilon(x - t) + n\epsilon((x - t)/t), \end{aligned}$$

where we have used Equation (1.6).

For $\eta > 0$, we fix t such that $\mathbb{P}(R > t) \leq \eta$. Note also that $\mathbb{P}(N(B(X, t)) > n) \leq \exp(-n \ln \frac{n}{C_1 t^d})$. Hence taking, $n = \lfloor 1/\sqrt{f(x)} \rfloor$, we deduce that

$$\limsup_x \mathbb{P}(F(xe_1, \mathcal{T}_0) \neq F(xe_1, \mathcal{T}_{-e_1})) \leq \eta,$$

and it follows $\lim_x \mathbb{P}(F(xe_1, \mathcal{T}_0) \neq F(xe_1, \mathcal{T}_{-e_1})) = 0$.

To complete the proof, notice that \mathcal{T}_{-e_1} is stationary: $F(xe_1, \mathcal{T}_{-e_1})$ and $F(0, \mathcal{T}_{-e_1})$ have the same distribution. \square

Remark 1.2.4 It is easy to check that the vector $X - \mathcal{A}(X)$ (and hence the progress $P(X)$) or the degree at X are stabilizing functional for \mathcal{T}_{-e_1} . So are the first k segments of the path from X to the origin in \mathcal{T}_{-e_1} , for all finite k , or the subtree of the directed navigation forest rooted in X and of depth k .

Theorem 1.2.3 has to be related to the convergence of graphs as it is defined for the Objective Method (refer to [5]). Let S_x denote the natural translation on geometric graphs induced by the translation by x of point sets. As an immediate corollary we have:

Corollary 1.2.5 *If Equation (1.6) holds and if $|X_n|$ tends to $+\infty$ and $X_n/|X_n|$ to e_1 then $S_{-X_n} \circ \mathcal{T}_0(N^{0, X_n})$ converges to $\mathcal{T}_{-e_1}(N^0)$ for the local weak convergence. Moreover if $(e_1^n), n \in \mathbb{N}$ converges to e_1 then $\mathcal{T}_{e_1^n}$ converges to \mathcal{T}_{e_1} for the local weak convergence.*

1.2.2 Sketch of Application: Spatial Average

In this paragraph, we explain how to prove the convergence of the spatial average of a stable functional of the navigation tree. It is not in the scope of this paragraph to state a precise result but rather to point out the good references. In the Chapter 2, Section 2.6 a detailed analysis will be done on the radial spanning tree. Let F be a stable functional on the navigation tree with value on \mathbb{R}_+ . We consider the sum

$$T(r) = \sum_{X \in N} \mathbf{1}(X \in B(0, r)) F(X, \mathcal{T}_0).$$

We assume that the conclusion of Theorem 1.2.3 holds, that $m_X = \mathbb{E}F(X, \mathcal{T}_0)$ depends only on $|X|$ and that m_{xe_1} converges to $m = \mathbb{E}F(0, \mathcal{T}_{e_1})$. From Slyvniack-Campbell Formula (see Appendix, §B.3)

$$\mathbb{E}T(r) = \omega_{d-1} \int_0^r m_{xe_1} x^{d-1} dx,$$

With the change of variable : $t = \frac{x}{r}$, this leads to :

$$\mathbb{E} \frac{T(r)}{r^d} = \omega_{d-1} \int_0^1 t^{d-1} m_{tre_1} dt,$$

The dominated convergence theorem together with $\lim_{x \rightarrow +\infty} m_{xe_1} = m$ gives:

$$\lim_{x \rightarrow \infty} \mathbb{E} \frac{T(r)}{r^d} = \omega_{d-1} m \int_0^1 t^{d-1} dt = m\pi_d.$$

Indeed we can hope to prove a stronger result: the almost sure and weak convergence of $\frac{T(r)}{r^d}$ to $m\pi_d$, that is the convergence of $T(r) = 1/\mathbb{E}N(B(0, r)) \sum_{X \in N} \mathbf{1}(X \in B(0, r)) F(X, \mathcal{T}_0)$ toward $1/\mathbb{E}N(B(0, r)) \sum_{X \in N} \mathbf{1}(X \in B(0, r)) F(X, \mathcal{T}_{e_1})$.

The weak convergence could be derived from Theorem 2.1 of Penrose and Yukich [133]. To prove an almost sure convergence, we consider a slightly different problem, we draw independently N points uniformly and get a finite point set $F_N = \{0, X_1, \dots, X_N\}$ and we build the navigation tree $\mathcal{T}_0^{F_N}$ on the point set F_N . We define $T(F_N) = \sum_{n=1}^N F(X_n, \mathcal{T}_0^{F_N})$, assume for example that F is homogeneous of order α , $T(\lambda F) = \lambda^\alpha T(F)$ for $\lambda > 0$. $N(B(0, r))/r^d$ tends a.s. toward π_d . Thus, by homogeneity, in order to prove that $\frac{T(r)}{r^d}$ converges almost surely toward $\pi_d m$ it is necessary and sufficient to prove that $\frac{T(F_N)}{N^{(d-\alpha)/d}}$ tends to $m\pi^{\alpha/d}$. Since we have already computed the mean of $\frac{T(r)}{r^d}$, it is sufficient to prove that $\frac{T(F_N)}{N^{d-\alpha/d}}$ converges a.s. toward a constant. If T satisfies a smoothness property, this will be a consequence of Rhee and Talagrand concentration inequalities, refer to the monographs of Yukich [161] and Steele [145].

It is important to notice that spatial average and path average have no reason to be equal when the navigation is not memoryless: $\lim_{r \rightarrow \infty} 1/N(B(0, r)) \sum_{X \in B(0, r)} F(X, \mathcal{T}_{e_1})$ could differ from $\lim_{|X| \rightarrow \infty} 1/H(X) \sum_{k=0}^{H(X)-1} F(\mathcal{A}^k(X), \mathcal{T}_{e_1})$. We will illustrate this remark on the radial navigation in the next chapter.

1.2.3 Example: Progress Distribution in the Small World

In this paragraph, we give an example of a computation of the distribution of a local functional of \mathcal{T}_{e_1} and \mathcal{T}_0 .

We consider the navigation on the Small World \mathcal{A} and the directed navigation depicted \mathcal{A}_{e_1} in §1.1.5, Model 3. We will soon check that the directed navigation is defined if and only if $\beta > d$. Let F denote the distribution function of the directed progress in the Small World $P_{e_1}(0) = \langle \mathcal{A}_{e_1}(X), e_1 \rangle$ and F_X the distribution function of the progress at X in the Small World $P(X) = |X| - |\mathcal{A}(X)|$.

Lemma 1.2.6 *Assume $d \geq 2$, the following properties hold:*

1. *If $\beta > d$, as t goes to infinity:*

$$\bar{F}(t) \sim \frac{2c\omega_{d-2}}{\beta-d} t^{d-\beta} \int_0^{\pi/2} \cos^{\beta-d} \theta d\theta.$$

2. *If $\beta > d$ then for all function $\epsilon \in \ell^0$*

$$\lim_{|X| \rightarrow +\infty} \sup_{t \leq |X| \epsilon(|X|)} t^{\beta-d} |F_X(t) - F(t)| = 0.$$

3. *If $d-2 < \beta < d$, the distribution of $|\mathcal{A}(X)|/|X|^{1-\frac{d-\beta}{2}}$ converges weakly and*

$$\sup_X \mathbb{E} \left(\left| \ln \frac{|\mathcal{A}(X)|}{|X|^{1-\frac{d-\beta}{2}}} \right| \mid \mathcal{A}(X) \neq 0 \right) < \infty.$$

4. *If $\beta = d$, let \tilde{F}_X be the distribution $\tilde{P}(X) = -\ln(1 - P(X)/X) \in [0, +\infty]$, \tilde{F}_X converges weakly to \tilde{F} with $\int \tilde{F}(s) ds = \tilde{\mu} \in (0, +\infty)$. Moreover, for all ϵ in ℓ^0*

$$\lim_{|X| \rightarrow +\infty} \sup_{t \leq \ln |X| \epsilon(|X|)} e^{2t} |\tilde{F}_X(t) - \tilde{F}(t)| = 0.$$

As we will see in the next section, the weak convergence results given in statements 2, 4 and 3 of this lemma will be used to derive various limits.

For $d \geq 3$ and $0 < \beta < d-2$ the reader should be convinced that similar weak convergence results hold. To avoid longer computations, we will not try to compute the explicit scaling at which the distribution of $|\mathcal{A}(X)|$ exhibits a non-degenerated limit.

The computation for $d = 1$ is simpler and the same result holds with different constants. Note that this lemma implies a similar result on Model 2, in statement 1, it suffices to rescale by $\mathbb{P}(P(0) = 0) = \exp(-\int_{\mathcal{H}(0)} f(y) dy)$ and statements 2, 4, and 3 hold without change.

All the distributions can be computed explicitly. The distribution \tilde{F} in statement 4 is given by Equation (1.9) and the weak limit of $|\mathcal{A}(X)|/|X|^{1-\frac{d-\beta}{2}}$ has a distribution obtained in Equation (1.8).

Proof. The proof relies on explicit computations and does not involve any subtle argument, we skip most details.

Statement 1.

Let $\mathcal{G} = (N, E)$ denote the Small World graph and $V(X) = \{Y : (X, Y) \in E\}$ the set of neighbors of X in the graph G , $V(X)$ is a non-homogenous Poisson point process of intensity

$f(|X - x|)dx$. We have

$$\begin{aligned}\mathbb{P}(P(0) > t) &= \mathbb{P}(V(0) \cap \mathcal{H}(te_1) \neq \emptyset) \\ &= 1 - \exp\left(-\int_{\mathcal{H}(te_1)} f(y)dy\right) \\ &\sim \int_{\mathcal{H}(te_1)} f(y)dy,\end{aligned}$$

as t tends to infinity. Let $\Lambda_t = \int_{\mathcal{H}(te_1)} f(y)dy$, writing $y = r \cos \theta e_1 + r \sin \theta e_2$ with $\langle e_1, e_2 \rangle = 0$ and $e_2 \in S^{d-1}$, we obtain

$$\begin{aligned}\Lambda_t &= 2\omega_{d-2} \int_0^{\pi/2} \int_{t/\cos\theta}^{\infty} f(r)r^{d-1}drd\theta \\ &\sim 2\omega_{d-2} \int_0^{\pi/2} \int_{t/\cos\theta}^{\infty} cr^{d-\beta-1}drd\theta \\ &\sim 2\frac{2c\omega_{d-2}}{\beta-d} \int_0^{\pi/2} \left(\frac{t}{\cos\theta}\right)^{d-\beta}d\theta \\ &\sim \frac{2c\omega_{d-2}}{\beta-d} t^{d-\beta} \int_0^{\pi/2} \cos^{\beta-d}\theta d\theta.\end{aligned}$$

Statement 2.

We can suppose without loss of generality that $X = -xe_1$, with $x > 0$. By definition, for $t < x$:

$$\begin{aligned}\mathbb{P}(P(X) > t) &= \mathbb{P}(V(X) \cap B(0, x-t)(t) \neq \emptyset) \\ &= 1 - \mathbb{P}(0 \in V(X)) \exp\left(-\int_{B(0, x-t)} f(|X - y|)dy\right) \\ &= 1 - (1 - f(x)) \exp\left(-\int_{B(0, x-t)} f(|X - y|)dy\right)\end{aligned}$$

In \mathbb{R}^2 for $u \in (0, 1)$ and $0 \leq \theta < \arcsin(1 - u)$, the straight line with equation $y = \tan \theta$ intersects the sphere of radius u and center $(1, 0)$ at two points of respective norms $A(\theta, u)$ and $B(\theta, u)$. A direct computation leads to

$$\begin{aligned}A(\theta, u) &= \cos \theta \left(1 - \sqrt{1 - \frac{u(2-u)}{\cos^2 \theta}}\right) = \frac{u}{\cos \theta} + o\left(\frac{u}{\cos \theta}\right) \\ B(\theta, u) &= \cos \theta \left(1 + \sqrt{1 - \frac{u(2-u)}{\cos^2 \theta}}\right) = 2 \cos \theta - \frac{u}{\cos \theta} + o\left(\frac{u}{\cos \theta}\right).\end{aligned}$$

Let $\Lambda_t(x) = \int_{B(0, x-t)} f(|X - y|)dy$, we get as t, x tend to infinity and t/x tends to 0:

$$\begin{aligned}\Lambda_t(x) &= 2\omega_{d-2} \int_0^{\arcsin(1-t/x)} \int_{xA(\theta, t/x)}^{xB(\theta, t/x)} f(r)r^{d-1}drd\theta \\ &\sim 2\omega_{d-2} \int_0^{\arcsin(1-t/x)} \int_{xA(\theta, t/x)}^{xB(\theta, t/x)} cr^{d-\beta-1}drd\theta \\ &\sim \frac{2c\omega_{d-2}}{\beta-d} \int_0^{\arcsin(1-t/x)} (xA(\theta, t/x))^{d-\beta} - (xB(\theta, t/x))^{d-\beta}d\theta \\ &\sim \bar{F}(t).\end{aligned}$$

It follows also

$$\begin{aligned} |\Lambda_t(x) - \Lambda(t)| &\leq \int_{\arcsin(1-t/x)}^{\pi/2} f(r)r^{d-1}drd\theta + \int_0^{\arcsin(1-t/x)} \int_{t/\cos(\theta)}^{xA(\theta,t/x)} f(r)r^{d-1}drd\theta \\ &\quad + \int_0^{\arcsin(1-t/x)} \int_{xB(\theta,t/x)}^{\infty} f(r)r^{d-1}drd\theta. \end{aligned}$$

If $t = x^{d-\beta}\epsilon(x)$, with $\epsilon \in \ell^0$, we easily get that $t^{\beta-d}|\Lambda_t(x) - \Lambda(t)|$ tends to 0.

Statement 3.

Let $U(X) = |\mathcal{A}(X)|/x^\alpha = (x - P(X))/x^\alpha$ with $|X| = x$ and $\alpha = 1 - (d - \beta)/2 \in (0, 1)$. Let $0 < s < x^{1-\alpha}$, we have

$$\begin{aligned} \mathbb{P}(U(X) < s) &= 1 - (1 - f(x)) \exp\left(-\int_{B(0, sx^\alpha)} f(|X - y|)dy\right), \\ &= 1 - (1 - f(x)) \exp(-\Lambda_{x-sx^\alpha}(x)), \end{aligned}$$

with as x tends to $+\infty$, uniformly in $s < x^{1-\alpha'}$, $\alpha' > \alpha$:

$$\begin{aligned} \Lambda_{x-sx^\alpha}(x) &\sim 2\omega_{d-2} \int_0^{\arcsin(sx^{\alpha-1})} \int_{xA(\theta, 1-sx^{\alpha-1})}^{xB(\theta, 1-sx^{\alpha-1})} cr^{d-\beta-1}drd\theta \\ &\sim \frac{2c\omega_{d-2}}{d-\beta} \int_0^{\arcsin(sx^{\alpha-1})} (xB(\theta, 1-sx^{\alpha-1}))^{d-\beta} - (xA(\theta, 1-sx^{\alpha-1}))^{d-\beta} d\theta. \end{aligned}$$

We have $B(\theta, 1-sx^{\alpha-1}) = \cos\theta(1 + \sqrt{s^2x^{2(\alpha-1)}/\cos^2\theta - \tan^2\theta}) = \cos\theta(1 + \sqrt{s^2x^{\beta-d}/\cos^2\theta - \tan^2\theta})$ and $A(\theta, 1-sx^{\alpha-1}) = \cos\theta(1 - \sqrt{s^2x^{\beta-d}/\cos^2\theta - \tan^2\theta})$. Hence as x tends to ∞ :

$$(xB(\theta, 1-sx^{\alpha-1}))^{d-\beta} - (xA(\theta, 1-sx^{\alpha-1}))^{d-\beta} \sim 2(d-\beta)x^{d-\beta} \cos^{d-\beta}\theta \sqrt{s^2x^{\beta-d}/\cos^2\theta - \tan^2\theta}.$$

and we obtain:

$$\begin{aligned} \Lambda_{x-sx^\alpha}(x) &\sim 4c\omega_{d-2} \int_0^{\arcsin(sx^{(\beta-d)/2})} x^{d-\beta} \cos^{d-\beta}\theta \sqrt{s^2x^{\beta-d}/\cos^2\theta - \tan^2\theta} d\theta \\ &\sim 4c\omega_{d-2}s^2. \end{aligned}$$

Finally we have proved that uniformly in $s < x^{(d-\beta)/2-\eta}$ (for some $\eta > 0$):

$$\lim_{|X| \rightarrow \infty} \mathbb{P}(U(X) > s) = \exp(-4c\omega_{d-2}s^2). \quad (1.8)$$

and this concludes the proof of statement 3.

Statement 4. Similarly, we still suppose that $X = -xe_1$, with $x > 0$, let $s > 0$ and $u = 1 - \exp(-s) \in (0, 1)$:

$$\begin{aligned} \mathbb{P}(\tilde{P}(X) > s) &= \mathbb{P}(P(X) > xu) \\ &= 1 - (1 - f(x)) \exp\left(-\int_{B(0, (1-u)x)} f(|X - y|)dy\right), \end{aligned}$$

as above with $\Lambda_t(x) = \int_{B(0, x-t)} f(|X - y|)dy$:

$$\begin{aligned} \Lambda_{ux}(x) &= 2\omega_{d-2} \int_0^{\arcsin(1-u)} \int_{xA(\theta, u)}^{xB(\theta, u)} f(r)r^{d-1}drd\theta \\ &\sim 2\omega_{d-2} \int_0^{\arcsin(1-u)} \int_{xA(\theta, u)}^{xB(\theta, u)} c/rdrd\theta \\ &\sim 2c\omega_{d-2} \int_0^{\arcsin(1-u)} \ln \frac{B(\theta, u)}{A(\theta, u)} d\theta \end{aligned}$$

We define

$$\begin{aligned}\tilde{F}(s) &= 1 - \exp(-2c\omega_{d-2} \int_0^{\arcsin(\exp(-s))} \ln \frac{B(\theta, 1 - \exp(-s))}{A(\theta, 1 - \exp(-s))} d\theta) \\ &= 1 - \exp(-c \int_{B(0, \exp(-s))} |e_1 - y|^{-d} dy).\end{aligned}\tag{1.9}$$

A direct analysis shows that, as s tends to $+\infty$:

$$\tilde{F}(s) \sim 4c\omega_{d-2}e^{-2s}.\tag{1.10}$$

The statement 4 follows. \square

1.3 Path average for memoryless navigation

In this section we assume that \mathcal{A} is a memoryless navigation and we derive various results on the asymptotic of $H(X)$, the generation of X in the navigation tree \mathcal{T}_0 .

1.3.1 Finite Mean Progress

Non-Homogeneous Renewal Equation

In this paragraph, we consider Equation (1.4). We assume that the distribution of $g(X, \mathcal{A}(X))$ and $P(X)$ is invariant by rotations with center 0. Let $x > 0$, $z(x) = \mathbb{E}g(xe_1, \mathcal{A}(xe_1))$, $Z(x) = \mathbb{E}G(xe_1)$ and F_x the distribution of $P(xe_1)$. from the independence property of the memoryless navigation, we deduce immediately:

$$Z(x) = z(x) + \int_0^x Z(x-r)F_x(dr),\tag{1.11}$$

We define also the mean generation, $U(x) = \mathbb{E}H(x)$:

$$U(x) = 1 + \int_0^x U(x-r)F_x(dr),\tag{1.12}$$

Let f be a non-negative function, the f -distance between two measures μ and ν on \mathbb{R} is:

$$d_f(\mu, \nu) = \sup_{\psi: |\psi(r)| \leq f(r)} \left| \int \psi(r)\mu(dr) - \int \psi(r)\nu(dr) \right|,$$

where the supremum is taken over continuous functions with compact support. If $f = 1$, the f -distance is the usual total variation distance. We assume:

- (i) $Z(x)$ is finite for all x .
- (ii) F_x converges in f -norm to F the directed distribution of progress with $f(r) = 1 + r$.
- (iii) $\mu = \int_0^\infty rF(dr) \in (0, +\infty)$.
- (iv) z is a bounded Riemann function and $l = \lim_{x \rightarrow +\infty} z(x)$ exists and is positive.

Theorem 1.3.1 *Let $a < b$, under the foregoing assumptions, as x tends to infinity,*

$$Z(x) \sim \frac{l}{\mu}x. \quad \text{and} \quad U(x+a) - U(x+b) \rightarrow \frac{b-a}{\mu}.$$

The proof relies on the Renewal Theorem and on a few technical lemmas.

Lemma 1.3.2 *There exists a positive constant C_1 such that*

$$Z(x) \leq C_1(x + 1).$$

Proof. Let $M(x) = \sup_{0 \leq t \leq x} Z(t)$ and L an upper bound for z . $M(x)$ is finite (Assumption (i)), M is non-decreasing and

$$M(x) \leq L + \int_0^x M(x-r)F_x(dr).$$

From Assumption (ii), the sequence of measures F_x converges in total variation and $F(\{0\}) < 1$ (indeed $\mu > 0$ by Assumption (iii)). Thus we may find $x_0 \geq \rho > 0$ such that for all $x \geq x_0$, $F([0, \rho], x) \leq 1/2$. We deduce for $x \geq x_0$:

$$M(x) \leq L + \frac{1}{2}M(x) + \frac{1}{2}M(x - \rho),$$

which in turn implies:

$$M(x) \leq \frac{2L}{\rho}x + M(x_0).$$

□

Lemma 1.3.3 *Let $\delta(x) = C_1 \int_0^x (x-r+1)|F_x(dr) - F(dr)|$. δ is a bounded Riemann function and*

$$\lim_{x \rightarrow \infty} \delta(x) = 0.$$

Proof. Since $\delta(x) \leq C_1 \int_0^\infty (r+1)|F_x(dr) - F(dr)|$ this lemma follows immediately from Assumption (ii). □

We state a straightforward corollary of the Renewal Theorem as it is stated in Feller [62].

Theorem 1.3.4 *If y is a bounded Riemann function, the solution Y of the renewal equation:*

$$Y(x) = y(x) + \int_0^x Y(x-r)F(dr)$$

satisfies as x tends to infinity:

$$Y(x) \sim \frac{1}{\mu} \int_0^x y(r)dr.$$

Now we can turn to the proof of Theorem 1.3.1.

Proof. Let \tilde{Z} be the solution of the renewal equation given by:

$$\tilde{Z}(x) = z(x) + \int_0^x \tilde{Z}(x-r)F(dr).$$

Assumption (iv) and Theorem 1.3.4 (applied to $y(x) = z(x)$) imply that $\tilde{Z}(x) \sim lx/\mu$. Note also:

$$\begin{aligned} |Z(x) - \tilde{Z}(x)| &\leq \int_0^x Z(x-r)|F_x(dr) - F(dr)| + \int_0^x |Z(x-r) - \tilde{Z}(x-r)|F(dr) \\ &\leq \delta(x) + \int_0^x |Z(x-r) - \tilde{Z}(x-r)|F(dr), \end{aligned}$$

where $\delta(x)$ is a bounded Riemann function in view of Lemmas 1.3.2 and 1.3.3. From Lemma 1.3.3 and Theorem 1.3.4 (applied to $y(x) = \delta(x)$):

$$\lim_{x \rightarrow \infty} \frac{|Z(x) - \tilde{Z}(x)|}{x} = 0.$$

Hence:

$$Z(x) \sim \tilde{Z}(x) \sim \frac{l}{\mu}x.$$

It remains to prove the more precise statement on the measure U . Let \tilde{U} the solution of Equation (1.12) where F_x is replaced by F . Let g be a non-decreasing function with $g(x) \leq x$ and $g(x)/x$ tends to 0 at infinity (g will be chosen later). We set $z(x) = \mathbf{1}(a, b)(x - g(x))$ and define Z and \tilde{Z} as above. Note that $Z(x) = U(x - g(x) - a) - U(x - g(x) - b)$ (resp. for \tilde{Z} and \tilde{U}).

F cannot be arithmetic since F is the limit of a distance between two points in a PPP. Then the Renewal Theorem (first form) (§XI.1 in [62]) implies:

$$\lim_{x \rightarrow \infty} \tilde{Z}(x) = \lim_{x \rightarrow \infty} \tilde{U}(x - a) - \tilde{U}(x - b) = \frac{b - a}{\mu}. \quad (1.13)$$

Moreover, with δ as in Lemma 1.3.3:

$$\begin{aligned} |Z(x) - \tilde{Z}(x)| &\leq \int_0^x |Z(x - r)|F_x(dr) - F(dr)| + \int_0^x |Z(x - r) - \tilde{Z}(x - r)|F(dr) \\ &\leq \delta(x) + \int_0^x |Z(x - r) - \tilde{Z}(x - r)|F(dr) \\ &\leq \delta(x) + \int_0^{x-g(x)} |Z(x - r) - \tilde{Z}(x - r)|F(dr), \end{aligned}$$

indeed $Z(x - r)$ and $\tilde{Z}(x - r)$ are equal to 0 for $x - r - g(x - r) \leq a \leq 0$ and thus for $r \geq x - g(x)$.

We deduce by Equation §XI.1 (1.5) in [62]:

$$|Z(x) - \tilde{Z}(x)| \leq \int_{x-g(x)}^x \delta(r)\tilde{U}(dr). \quad (1.14)$$

Set $I_n = [n, n + 1)$, $n \in \mathbb{N}$. From Assumption (ii) $\sup_{x \in I_n} \delta(x) = m_n < \infty$, let $\tilde{\delta}(x) = \sum_n m_n \mathbf{1}(x \in I_n)$. $\tilde{\delta}$ is a bounded Riemann function and $\lim_{x \rightarrow \infty} \tilde{\delta}(x) = \lim_{n \rightarrow \infty} m_n = 0$. By Lemma 1.7.1 (at the end of this chapter), we may suppose that g has been chosen so that $\int_{x-g(x)}^x \tilde{\delta}(r)dr$ tends to 0 as x tends to infinity.

Equation §XI.1 (1.17) in [62] stated for Equation (1.14) asserts:

$$\lim_{x \rightarrow \infty} |Z(x) - \tilde{Z}(x)| \leq \frac{1}{\mu} \lim_{x \rightarrow \infty} \int_{x-g(x)}^x \tilde{\delta}(r)dr = 0.$$

The theorem follows then from Equation (1.13). \square

Remark 1.3.5 \tilde{Z} is the expectation of the weight of the path from xe_1 to $-\mathcal{H}_{e_1}(0)$ in the directed navigation tree.

Law of Large Numbers

We now prove an almost sure convergence result for $H(X)$ on the path $\pi(X)$ from X to 0 in the memoryless navigation with non-negative progress.

Proposition 1.3.6 *Assume that F_X converges weakly as $|X|$ tends to infinity to F and that (F_X) is uniformly integrable then a.s.*

$$\lim_{|X| \rightarrow +\infty} \frac{H(X)}{|X|} = \frac{1}{\mu},$$

where $\mu = \int_0^\infty rF(dr) < \infty$.

Before proving this proposition, we will state two lemmas. The first lemma will be often used.

Lemma 1.3.7 *Let \mathcal{A} is a navigation with a.s. positive progress on a PPP or a PWIT. Let $x_0 \geq 0$, $\tau(X) = \inf\{k \geq 0 : |\mathcal{A}^k(X)| \leq x_0\}$, and let $\ell(X)$ be a positive $\mathbb{R}^d \rightarrow \mathbb{R}_+$ function tending to ∞ as $|X|$ tends to ∞ . If a.s. (resp. in L^p) $\tau(X)/\ell(X)$ converges to Z then a.s. (resp. in L^p) $H(X)/\ell(X)$ converges to Z .*

Proof. We have:

$$\tau(X) \leq H(X) \leq \tau(X) + \sup_{Y \in B(0, x_0) \cap N^{0, X_{\tau(X)}}} H(Y),$$

hence it is sufficient to prove that, for s small enough:

$$\mathbb{E} \sup_{Y \in N \cap B(0, x_0)} \exp(sH(Y)) < \infty.$$

The progress is a.s. positive: $\mathcal{A}(X) \in B(0, |X|)$, it follows that for a navigation on a PPP: $\mathbb{E} \sup_{Y \in N \cap B(0, x_0)} \exp(sH(Y)) \leq \mathbb{E} \exp(sN(B(0, x_0))) < \infty$.

For a navigation on a PWIT, the proof is slightly different. The vertices in $T^{0, X}$ of first generation is a PPP, and $|\mathcal{A}(X)| \leq t(X)$ with $t(X) = \arg \sup_{Y \in N \cap B(0, |X|)} |Y|$. $C(X, t) = B(0, |X|) \setminus B(0, |X| - t)$, $t(X)$ is a stopping time for the filtration $\{\mathcal{F}_{C(X, t)}^N\}_{0 \leq t \leq |X|}$. Since $N \cap C(X, t)$ is independent of $N \cap B(0, t)$, we obtain: $\mathbb{E} \exp(sH(Y)) \leq \mathbb{E} \exp(sN(B(0, |Y|))) < \infty$ for s small enough. Let $(U_k), k \in \mathbb{N}$, be an iid sequence of r.v. with the distribution of $\exp(sN(B(0, x_0)))$. From the independency of the subtrees in a PWIT and using Wald's formula, we get

$$\mathbb{E} \sup_{Y \in N \cap B(0, x_0)} \exp(sH(Y)) \leq \mathbb{E} \sum_{k=0}^{N(B(0, x_0))} U_k = \pi_d x_0^d \mathbb{E} U_1 < \infty.$$

□

We consider the following property:

$$\text{If } \epsilon \in \ell^0 \text{ then } \lim_{|X| \rightarrow \infty} \int_0^{|X|^{\epsilon(|X|)}} |F_X(t) - F(t)| dt = 0. \quad (1.15)$$

From Markov Inequality, Property (1.15) is implied by the stronger property, for some $\alpha > 1$:

$$\text{If } \epsilon \in \ell^0 \text{ then } \lim_{|X| \rightarrow \infty} \sup_{t \leq |X|^{\epsilon(|X|)}} t^\alpha |F_X(t) - F(t)| dt = 0,$$

which has already appeared in Lemma 1.2.6. The next lemma asserts that Property (1.15) is implied by the assumptions done in Proposition 1.3.6.

Lemma 1.3.8 *If F_X converges in f -norm to F with $f(r) = r$ then Property (1.15) holds. Conversely, if F_X converges weakly to F and $\{F_X\}_{X \in \mathbb{R}^d}$ is uniformly integrable then F_X converges in f -norm to F with $f(r) = r$.*

Proof. Let $\eta > 0$, there exists x_0 such that for all X , $|X| \geq x_0$,

$$\sup_{\psi: |\psi(r)| \leq r} \left| \int \psi(r) F_X(dr) - \int \psi(r) F(dr) \right| \leq \eta.$$

Let $\Delta_X(t) = 1 - |F_X(t) - F(t)|$ and $I = \{t : F_X(t) > F(t)\}$, we have

$$\begin{aligned} \int \bar{\Delta}_X(t) dt &= \int |\bar{F}_X(t) - \bar{F}(t)| dt \\ &= \int_I \int_t^\infty F_X(dr) dt - \int_I \int_t^\infty F(dr) dt - \int_{I^c} \int_t^\infty F_X(dr) dt + \int_{I^c} \int_t^\infty F(dr) dt \\ &= \int \phi(r) F_X(dr) - \int \phi(r) F(dr) \\ &\leq \eta, \end{aligned}$$

where we have used Fubini's Theorem and set $\phi(r) = r\mathbf{1}(r \in I) - r\mathbf{1}(r \in I^c)$, $|\phi(r)| \leq r$.

We now prove the converse statement, the hypothesis imply that for all $\eta > 0$ there exists T such that for all X $\int_T^{+\infty} F_X(t) dt \leq \eta$ and $\int_T^{+\infty} F(t) dt \leq \eta$. Let $\psi(r) \leq r$, $I = \{t : F_X(t) > F(t)\}$ and $\phi(r) = r\mathbf{1}(r \in I) - r\mathbf{1}(r \in I^c)$. As above:

$$\begin{aligned} \left| \int \psi(r) F_X(dr) - \int \psi(r) F(dr) \right| &\leq \left| \int \phi(r) F_X(dr) - \int \phi(r) F(dr) \right| \\ &\leq \int |F_X(t) - F(t)| dt \\ &\leq 2\eta + \int_0^T |F_X(t) - F(t)| dt. \end{aligned}$$

and the second term tends to 0 by assumption. \square

We turn to the proof of Proposition 1.3.6.

Proof. We first assume that $\mu > 0$. Let $0 < \eta < \mu/2$ and $\epsilon(X) = 1/\sqrt{|X|}$, by Lemma 1.3.8 we may find x_0 and a function f such that if $|X| \geq x_0$:

$$\mathbf{1}(t \leq \sqrt{|X|})(\bar{F}(t) - f(t)) \leq \bar{F}_X(t) \leq \bar{F}(t) + f(t).$$

where $\int f(t) dt \leq \eta$, $f(t) \leq \bar{F}(t)$ and $\int_0^{\sqrt{|X|}} \bar{F}(t) - f(t) dt \geq \mu - 2\eta$.

Let $\tau(X) = \inf\{n : |X_n| \leq x_0\}$ and $(U_n), n \in \mathbb{N}$, (resp. $(V_n), n \in \mathbb{N}$) be an iid sequence of variables with tail distribution $1 \wedge (\bar{F} + f)$ (resp $\bar{F} - f$). We now define: $Y_n = |X| - \sum_{k=0}^{n-1} U_k$, $Z_n = |X| - \sum_{k=0}^{n-1} V_k \mathbf{1}(V_k \leq \sqrt{x_0})$,

$$\tau_+(X) = \inf\{n : |Y_n| \leq x_0\} \quad \text{and} \quad \tau_-(X) = \inf\{n : |Z_n| \geq x_0\}.$$

From Lemma 1.7.2 (at the end of this chapter):

$$\mathbf{1}(\tau(X) > n) Z_n \stackrel{st}{\leq} \mathbf{1}(\tau(X) > n) |X_n| \stackrel{st}{\leq} \mathbf{1}(\tau(X) > n) Y_n$$

We deduce that:

$$\tau_-(X) \stackrel{st}{\leq} \tau(X) \stackrel{st}{\leq} \tau_+(X). \quad (1.16)$$

We have $\mathbb{E}U_n \leq \mu + \eta$ and $\mathbb{E}V_n \mathbf{1}(V_n \leq \sqrt{x_0}) \geq \mu - 2\eta$. By the elementary renewal Theorem, a.s.:

$$\liminf_X \frac{\tau_-(X)}{|X|} \geq \frac{1}{\mu + \eta}. \quad \text{and} \quad \limsup_X \frac{\tau_+(X)}{|X|} \leq \frac{1}{\mu - 2\eta}. \quad (1.17)$$

From Equations (1.16) and (1.17) we get a.s.: $\liminf_X \tau(X)/|X| \geq 1/(\mu + \eta)$ and $\limsup_X \tau(X)/|X| \leq 1/(\mu - 2\eta)$. Then by Lemma 1.3.7, $H(X)/|X|$ tends a.s. to $1/\mu$. For $\mu = 0$, considering only $\tau_-(X)$, the same proof works. \square

1.3.2 α -Stable Model

We now turn to the case, $0 < \alpha < 1$, $c > 0$:

$$\bar{F}(t) \sim_{t \rightarrow +\infty} \frac{c}{t^\alpha}. \quad (1.18)$$

In this model, the directed progress is a.s. finite but it has an infinite mean. This case is slightly more complex than the previous. The tail of F is very large and due to some large jumps, the directed navigation differs significantly from the navigation. In view of Lemma 1.2.6, the extra assumption is

$$\text{If } \epsilon \in \ell^0 \text{ then } \lim_{|X| \rightarrow \infty} \sup_{t \leq |X|\epsilon(|X|)} t^\alpha |F_X(t) - F(t)| = 0. \quad (1.19)$$

This assumption is a uniformity assumption on the convergence of F_X to F to guarantee that the tail of F_X converges uniformly to the tail of F .

Proposition 1.3.9 *Let χ_α a random variable with α -stable distribution: $\mathbb{E} \exp(-s\chi_\alpha) = \exp(-s^\alpha)$. If Equations (1.18) and (1.19) hold then*

$$\lim_{|X| \rightarrow \infty} \mathbb{P}\left(\frac{H(X)}{|X|^\alpha} \geq t\right) \geq \mathbb{P}(\chi_\alpha^{-1/\alpha} \geq \Gamma(1-\alpha)ct)$$

and

$$\limsup_{|X| \rightarrow \infty} \frac{\mathbb{E}H(X)}{|X|^\alpha} \leq 2\frac{1-\alpha}{c}.$$

This proposition is somewhat disappointing: we have not managed to prove that $H(X)/|X|^\alpha$ converges in law. Equation (1.19) is the best convergence that we can hope to prove however it is not sufficient: directed navigation and navigation do not have the same exact asymptotic behavior.

Proof. The proof of this proposition is similar to the proof of Proposition 1.3.6. Let $\epsilon(X) \in \ell^0$ such that $|X|\epsilon(|X|)$ tends to infinity and fix $\eta \in (0, c)$. By Equation (1.19), we may find x_0 such that for all X with $|X| \geq x_0$:

$$\mathbf{1}(t \leq |X|\epsilon(|X|))(\bar{F}(t) - \eta f(t)) \leq \bar{F}_X(t) \leq \bar{F}(t) + \eta f(t), \quad (1.20)$$

where $0 \leq \eta f(t) \leq \bar{F}(t)$ and $f(t) \sim t^{-\alpha}$.

Let $\tau(X) = \inf\{n : |X_n| \leq x_0\} \leq H(X)$. Following the proof of Theorem 1.3.6 and using Lemma 1.7.5 (at the end of this chapter), the right hand side of Equation (1.20) gives:

$$\liminf_X \mathbb{P}\left(\frac{\tau(X)}{|X|^\alpha} \geq t\right) \geq \mathbb{P}(\chi_\alpha^{-1/\alpha} \geq \Gamma(1-\alpha)(c+\eta)t).$$

The proof of the left hand side of Equation (1.20) uses Lemma 1.7.7 (at the end of this chapter):

$$\limsup_X \frac{\mathbb{E}\tau(X)}{|X|^\alpha \epsilon(|X|)^{\alpha-1}} \leq \frac{1-\alpha}{c-\eta}.$$

Since this last equation holds for all function $\epsilon(|X|)$ tending to 0 at infinity we deduce:

$$\limsup_X \frac{\mathbb{E}\tau(X)}{|X|^\alpha} < \infty.$$

Then using Lemma 1.3.7 we deduce that $\limsup \mathbb{E}H(X)/|X|^\alpha < \infty$. We can go one step further, using Remark 1.7.8, we have: $\limsup_X \mathbb{E}H(X)/|X|^\alpha \leq 2(1-\alpha)/c$. Indeed, fix $\eta > 0$ and let $\epsilon_k(X) = |X|^{1/k}$, for $|X|$ large enough, for all k : $\mathbb{E}H(X)/|X|^{1/k+\alpha(k-1)/k} \leq 2(1-\alpha)/c+\eta$. (from Equation (1.69)). \square

Remark 1.3.10 If we had supposed instead that the directed progress tail was equivalent to $l(t)/t^\alpha$ for a slowly varying function l then the same type of convergence result holds with $|X|^\alpha$ replaced by $|X|^\alpha/l(|X|)$.

1.3.3 Relatively Stable Model

We now turn to a limit case for some $c > 0$:

$$\bar{F}(t) \sim_{t \rightarrow +\infty} \frac{c}{t} \quad (1.21)$$

Proposition 1.3.11 *If Equation (1.21) holds and*

$$\text{If } \epsilon \in \ell^0 \text{ then } \lim_{|X| \rightarrow \infty} \sup_{t \leq |X|\epsilon(|X|)} t|F_X(t) - F(t)| = 0, \quad (1.22)$$

then a.s.

$$\lim_{|X| \rightarrow \infty} \frac{H(X) \ln |X|}{|X|} = \frac{1}{c}$$

Proof. The proof is similar to the proof of Proposition 1.3.9. We fix a function $\epsilon(X)$ tending to 0 with $|X|\epsilon(X)$ tending to infinity. Equation (1.20) still holds with $f(t) \sim 1/t$. Using Lemmas 1.7.6 and 1.7.7, we deduce:

$$\text{a.s. } \liminf_{|X| \rightarrow \infty} \frac{H(X) \ln |X|}{|X|} \geq \frac{1}{c} \quad \text{and} \quad \limsup_{|X| \rightarrow \infty} \frac{\mathbb{E}H(X) \ln |X|\epsilon(|X|)}{|X|} \leq \frac{1}{c}$$

If $\epsilon(|X|) = |X|^{-1/n}$, we have: $\limsup \frac{\mathbb{E}H(X) \ln |X|}{|X|} \leq n/(c(n-1))$. This last equation holds for all n , hence: $\limsup \frac{\mathbb{E}H(X) \ln |X|}{|X|} \leq 1/c$. \square

1.3.4 Scaled Progress

We discuss in this paragraph cases when $P(X)$ does not converge toward an asymptotic progress but rather $|X|^{-\alpha}(|X| - P(X))$ for some $0 < \alpha \leq 1$.

Scale Free Progress

A case which has an important impact in applications is $\alpha = 1$: the *scaled distribution of progress*, $P(X)/|X|$, converges weakly to a non-degenerate limit. Following Meester and Franceschetti in [68], a navigation is *scale free* if the distribution of $P(X)/|X|$ does not depend on X . Similarly the distribution is *asymptotically scale free* if the distribution of $P(X)/|X|$ converges weakly to a non degenerate limit. Let $\tilde{P}(X) = -\ln(1 - P(X)/|X|) \in \mathbb{R}_+ \cup \{+\infty\}$ and $\tilde{F}_X(t) = \mathbb{P}(\tilde{P}(X) \leq t)$. Note that $\mathbb{P}(\tilde{P}(X) = \infty)$ may be positive. We assume that \tilde{F}_X converges weakly to some limit distribution \tilde{F} . Define for $0 \leq i < H(X) - 1$, $\tilde{P}_i = -\ln(1 - P(X_i)/|X_i|)$, we have $|X_k| = |X| \prod_{i=0}^{k-1} (1 - P(X_i)/|X_i|)$ and $\ln |X_k| = \ln |X| - \sum_{i=0}^{k-1} \tilde{P}_i$. The corresponding path in $\mathbb{R} \cup \{-\infty\}$ is $\tilde{\pi}(X) = \{\ln |X|, \ln |X| - \tilde{P}_0, \dots, -\infty\}$. Let $\tau(X) = \sup\{n : \ln |X_n| < 0\}$, from Lemma 1.3.7 a.s. $\tau(X)$ and $H(X)$ are equivalent as $|X|$ tends to infinity (provided that they tend to infinity). We may apply Proposition 1.3.6 to the path $\tilde{\pi}(X)$ up to $\ln |X_{\tau(X)}|$. We deduce the following proposition.

Proposition 1.3.12 *If \tilde{F}_X converges weakly to \tilde{F} as $|X|$ tends to infinity and (\tilde{F}_X) is uniformly integrable then a.s.*

$$\lim_{|X| \rightarrow +\infty} \frac{H(X)}{\ln |X|} = \frac{1}{\tilde{\mu}},$$

where $\tilde{\mu} = \int s\tilde{F}(ds) < \infty$.

Subcritical Case

We study the case when $(|X| - P(X))|X|^{-\alpha}$ is non-degenerate for some $0 < \alpha < 1$. Let $U(X) = |\mathcal{A}(X)||X|^{-\alpha} = (|X| - P(X))|X|^{-\alpha}$.

Proposition 1.3.13 *Assume that $\sup_{X \in \mathbb{R}^d} \mathbb{E}(|\ln U(X)| | U(X) \neq 0) < +\infty$ then a.s.*

$$\lim_{|X| \rightarrow +\infty} \frac{H(X)}{\ln \ln |X|} = -\frac{1}{\ln \alpha}.$$

Note that the proposition does not require any weak convergence of $U(X)$ toward a non-degenerate limit. The following proof is perhaps longer than necessary.

Proof. For $1 \leq k \leq H(X)$, let $U_k = |X_k||X_{k-1}|^{-\alpha}$. If $k < H(X)$, $\ln |X_k| = \alpha^k \ln |X| + \sum_{i=1}^k \alpha^{k-i} \ln U_i$, hence:

$$\ln |X_k| = \alpha^k \ln |X| + R_k, \quad (1.23)$$

with $|R_k| \leq Z_k = \sum_{i=1}^k \alpha^{k-i} |\ln U_i|$. With the convention that $Z_k = 0$ for $k \geq H(X)$, $(Z_k, X_k), k \in \mathbb{N}$, is a Markov chain and

$$Z_{k+1} = \alpha Z_k + |\ln U_{k+1}|.$$

Let $0 < \beta < 1 - \alpha$, by assumption there exists C_1 such that $\sup_{X \in \mathbb{R}^d} \mathbb{E} \mathbf{1}(U(X) \neq 0) |\ln U(X)| \leq C_1$ (with the convention " $0 \times \infty = 0$ "). It follows

$$\begin{aligned} \mathbb{E}(\mathbf{1}(H(X) > k+1)(Z_{k+1} - Z_k) | Z_k = z) &\leq -(1 - \alpha)z + C_1 \\ &\leq -\beta z + C_1 \mathbf{1}(z \in C), \end{aligned} \quad (1.24)$$

with $C = \{z \in \mathbb{R}_+ : z \leq C_1/(1 - \alpha - \beta)\}$. Equation (1.24) is a geometric drift condition on a Markov chain (see (V4), p371 in Meyn and Tweedie [123]). Let $K = \inf\{k \geq 1 : Z_k \in C\}$, by Theorem 15.2.5 in [123], for some $s > 0$,

$$\sup_{z \in C} \mathbb{E}(e^{s(K \wedge H(X))} | Z_0 = z) < \infty. \quad (1.25)$$

Set $x_0 = \exp(1 + C_1/(1 - \alpha - \beta))$, by Lemma 1.3.7, it is sufficient to show that a.s.

$$\lim_{|X| \rightarrow +\infty} \frac{\tau(X)}{\ln \ln |X|} = -\frac{1}{\ln \alpha},$$

where $\tau(X) = \inf\{k \geq 0 : |X_k| \leq x_0\}$. We fix $\epsilon > 0$ and let $(X^n), n \in \mathbb{N}$, be a sequence in \mathbb{R}^d such that $|X^n|$ tends to infinity. We define $K(n, \epsilon) = \lfloor -(1 + \epsilon)(\ln \ln |X^n|)/(\ln \alpha) \rfloor$ and $K'(n, \epsilon) = H(X) \wedge \inf\{k \geq K(n, \epsilon) : Z_k \in C\}$. From Borel-Cantelli Lemma and Equation (1.25), a.s. for n large enough $K'(n, \epsilon/3) \leq 2K(n, \epsilon/3) \leq K(n, \epsilon)$. Therefore for n large enough, from Equation (1.23):

$$\ln |X_{K(n, \epsilon)}| \leq \ln |X_{K'(n, \epsilon/3)}| \leq (\ln |X^n|)^{-\epsilon/3} + C_1/(1 - \alpha - \beta) \leq \ln x_0,$$

and it follows that a.s.

$$\limsup_X \frac{\tau(X)}{\ln \ln |X|} \leq -\frac{1}{\ln \alpha}.$$

The same computation can be done with $K(n, -\epsilon)$ to get a lower bound. \square

1.3.5 Average along a Path

We have so far taken interest only in $H(X)$, more generally we may try to find some almost sure convergence results for

$$G(X) = \sum_{i=0}^{H(X)-1} g(X_i, X_{i+1}) = g(X, \mathcal{A}(X)) + G(\mathcal{A}(X)).$$

$H(X)$ is the case $g = 1$. This is straightforward to generalize our results to $G(X)$. The same analysis can be done and we obtain for example:

Lemma 1.3.14 *Assume that $H(X)$ tends almost surely to infinity, that $(g(X, \mathcal{A}(X)))_{X \in \mathbb{R}^d}$ converges weakly as $|X|$ tends to infinity and $(g(X, \mathcal{A}(X)))_{X \in \mathbb{R}^d}$ is uniformly integrable then a.s.:*

$$\lim_{|X| \rightarrow \infty} \frac{G(X)}{H(X)} = \nu(g),$$

where $\nu(g) = \lim_{|X| \rightarrow +\infty} \mathbb{E}g(X, \mathcal{A}(X))$.

The proof of this lemma is omitted since it is identical to the proof of Proposition 1.3.6.

It is possible to get a convergence result even when no weak convergence holds.

Lemma 1.3.15 *Assume that $H(X)$ tends almost surely to infinity, that $\nu(g) = \lim_{|X| \rightarrow +\infty} \mathbb{E}g(X, \mathcal{A}(X))$ exists and that $\sup_{X \in \mathbb{R}^d} \mathbb{E}|g(X, \mathcal{A}(X))|^2$ is finite, then a.s.*

$$\lim_{|X| \rightarrow \infty} \frac{G(X)}{H(X)} = \nu(g).$$

Proof. As above \mathcal{F}_n denotes the σ -algebra generated by X_0, \dots, X_n . Since $\mathbb{E}(|g(X_k, X_{k+1})|^2) < M < \infty$, from Theorem VII.9.3 of Feller [62] a.s.

$$\lim_{n \rightarrow +\infty} \frac{1}{n} \sum_{k=0}^{H(X)-1} g(X_k, X_{k+1}) - \mathbb{E}(g(X_k, X_{k+1}) | \mathcal{F}_k) = 0. \quad (1.26)$$

For a memoryless navigation $\mathbb{E}(g(X_k, X_{k+1}) | \mathcal{F}_k) = \mathbb{E}(g(X_k, X_{k+1}) | X_k)$, thus our assumption implies a.s. $\lim_{|X| \rightarrow +\infty} \mathbb{E}(g(X_k, X_{k+1}) | \mathcal{F}_k) = \nu(g)$ and consequently a.s.:

$$\lim_{|X| \rightarrow +\infty} \frac{1}{H(X)} \sum_{k=0}^{H(X)-1} \mathbb{E}(g(X_k, X_{k+1}) | \mathcal{F}_k) = \nu(g). \quad (1.27)$$

Equations (1.26) and (1.27) lead to:

$$\lim_{|X| \rightarrow +\infty} \frac{G(X)}{H(X)} = \lim_{|X| \rightarrow +\infty} \frac{1}{H(X)} \sum_{k=1}^{H(X)} g(X_k, X_{k+1}) = \nu(g).$$

□

Remark 1.3.16 If the assumptions of the lemma hold with $g(X, Y) = |X| - |Y|$, then, since $g(X, \mathcal{A}(X)) = P(X)$, we obtain, a.s.:

$$\frac{|X|}{H(X)} \rightarrow \mu.$$

This is an alternative proof for the convergence of $H(X)/|X|$ (under different conditions).

1.4 Path Average for Navigation

We now turn to a more challenging question: the analysis of decentralized navigation on a PPP. The analysis in the PWIT or in a memoryless navigation was greatly simplified by the fact that the progress $P(X_k)$ was depending on the past history $\mathcal{F}_k = \sigma(X_0, \dots, X_k)$ through the sole position of X_k . This property enabled us to rewrite the path as a non-homogeneous random walk.

As it pointed in [59] there is a technical issue to cope with in a navigation \mathcal{A} on the PPP: the dependency structure is much more complicated. In the Small World navigation for example, if $\mathcal{A}(X) = Y$ then it implies that there are (stochastically) fewer points of N^0 in $B(0, |Y|)$. So the navigation along these edges will not have the nice property of the navigation on the PWIT. We will circumvent this difficulty by a coupling argument, more precisely we will prove that the navigation in the Small World is regenerative.

1.4.1 Path Average for Regenerative Navigation

In this paragraph, we exhibit some sufficient conditions for a regenerative navigation to have converging path averages. Let \mathcal{A} be a regenerative navigation and θ its regenerative time: \mathcal{A}^θ is a memoryless navigation. We define $P(X) = |X| - |\mathcal{A}(X)|$ and $P^\theta(X) = |X| - |\mathcal{A}^\theta(X)|$. Let $\theta_0 = 0$, $\theta_1 = \theta$ and $\theta_k = \theta(X_{k-1})$, for $k \geq 1$. We define $H^\theta(X) = \inf\{k \geq 0 : \mathcal{A}^{\theta_k}(X) = 0\}$. The next lemma is elementary but nevertheless useful.

Lemma 1.4.1 *Let $\ell(X)$ be a positive $\mathbb{R}^d \rightarrow \mathbb{R}_+$ function tending to ∞ as $|X|$ tends to ∞ . We assume:*

1. $H^\theta(X)/\ell(X)$ tends a.s. to $1/\mu$, $\mu > 0$.
2. $\mathbb{E}\theta = \bar{\theta} < \infty$.

Then the following limit holds a.s.

$$\lim_{|X| \rightarrow +\infty} \frac{H(X)}{\ell(X)} = \frac{\bar{\theta}}{\mu}.$$

Proof. Note that $\theta_{H^\theta(X)-1} < H(X) \leq \theta_{H^\theta(X)}$ hence:

$$\frac{\theta_{H^\theta(X)-1}}{\ell(X)} < \frac{H(X)}{\ell(X)} \leq \frac{\theta_{H^\theta(X)}}{\ell(X)}.$$

Let $\tilde{\mathcal{A}} = \mathcal{A}^\theta$, we can apply Lemma 1.3.14 to $g(X, \tilde{\mathcal{A}}(X)) = \theta(X)$: we get that $\theta_{H^\theta(X)}/H^\theta(X)$ converges almost surely to $\bar{\theta}$. \square

This simple lemma states that the behavior on regenerative navigation relies on the behavior of its embedded memoryless navigation.

1.4.2 Directed Navigation on the Discrete Lattice Small World

The aim of this paragraph is pedagogical: on the simplest example we build a regenerative sequence. The point set N is a thinned 1-dimensional lattice. More precisely, let $(U_i), i \in \mathbb{Z}$, be a sequence of iid Bernoulli random variable, $\mathbb{P}(U_i = 1) = p > 0$. A point $i \in \mathbb{Z}$ is in N if $U_i = 1$:

$$N = \sum_{i \in \mathbb{Z}} U_i \delta_i.$$

The connection graph $\mathcal{G} = (N, E)$ is a Small World graph: vertices i and j are connected with probability: $|i - j|^{-\beta}$, $\beta > 1$, independently of the other conditioned on the event that i has at least one neighbor on its right. Let $(V_{ij}), i < j, i, j \in \mathbb{Z}$, be a sequence of random variable on $[0, 1]$ and $V_{ij} = V_{ji}$, $V_{ii} = 0$. There is an edge between i and j if $V_{ij} \leq |i - j|^{-\beta}$. We consider a maximal directed progress navigation to the right:

$$\mathcal{A}(i) = \sup\{j \in N : (i, j) \in E\} = \sup\{j \in N : V_{ij} \leq |i - j|^{-\beta}\}.$$

We assume that $(V_{ij}), i < j, i, j \in \mathbb{Z}$ is independent and uniformly distributed conditioned on the event: $\Omega = \cup_i \Omega_i$ and $\Omega_i = \{\sum_{j \geq 1} U_j \mathbf{1}(V_{ij} \leq |j - i|^{-\beta}) > 0\}$. In the computations $(\tilde{V}_{ij}), i < j, i, j \in \mathbb{Z}$ will denote a sequence of iid variables uniform on $[0, 1]$. We have $\mathbb{P}(\sum_{j \geq 1} U_j \mathbf{1}(\tilde{V}_{ij} \leq |j - i|^{-\beta}) > 0) = 1 - \prod_{j \geq 1} (1 - \frac{p}{j^\beta}) = \lambda^{-1}$.

As above the directed progress is defined by $P(i) = \mathcal{A}(i) - i > 0$. For $t \geq 1$:

$$\begin{aligned} \mathbb{P}(P(i) = t) &= \lambda \mathbb{P}(\{U_t \mathbf{1}(\tilde{V}_{i,i+t} \leq t^{-\beta}) = 1\} \cap_{k \geq t+i+1} \{U_k \mathbf{1}(\tilde{V}_{ik} > |k - i|^{-\beta}) = 0\}) \\ &= \lambda \frac{p}{t^\beta} \prod_{j > t} (1 - \frac{p}{j^\beta}) \end{aligned}$$

From similar computations, we also obtain for $\beta > 1$, as t tends to infinity:

$$\mathbb{P}(P(i) \geq t) = 1 - \lambda \left(1 - \prod_{j < t} (1 - \frac{p}{j^\beta})\right) \prod_{j \geq t} (1 - \frac{p}{j^\beta}) \sim \frac{p}{\beta - 1} t^{1-\beta}. \quad (1.28)$$

It follows that $P(i)$ is almost surely finite for $\beta > 1$ and that $\mathbb{E}P(i)$ is finite for $\beta > 2$.

We define $X_0 = 0$, $X_k = \mathcal{A}^k(0)$, $P_k = P(X_k) = X_{k+1} - X_k$. Let $N_j = N \cap [j + 1, +\infty] - j$, $N_{X_k} = \sum_{i \geq 1} U_{X_k+i} \delta_i$, N_{X_k} is the future of the navigation sequence. In particular $N_0 = \sum_{i \geq 1} U_i \delta_i$, where (U_i) are iid Bernoulli variable. The distribution of $N_{X_k}, k \geq 1$, is not as simple as the distribution of N_0 : X_k and $(U_i)_{i > X_k}$ are correlated: *the navigation is anticipating with respect to the natural spatial filtration*.

Consider the same navigation on \mathbb{Z} with the same V_{ij} : $\bar{\mathcal{A}}(i) = \sup\{j \in \mathbb{Z} : V_{ij} \leq |i - j|^{-\beta}\}$. Similarly, we can compute the distribution of $\bar{P}(i) = \bar{\mathcal{A}}(i) - i$. It is important to notice that $\bar{P}(i) \geq P(i)$ and for $t \in \mathbb{N}$:

$$\mathbb{P}(\bar{P}(i) = P(i)) = \lambda p \quad \text{and} \quad \mathbb{P}(\bar{P}(i) - P(i) \geq t) \leq C_1 t^{2(1-\beta)}, \quad (1.29)$$

for some positive constant C_1 . The first equality comes from the fact that $\mathbb{P}(\bar{P}(i) = P(i)) = \mathbb{P}(U_{\bar{\mathcal{A}}(i)} = 1) = \lambda \mathbb{P}(U_{\bar{\mathcal{A}}(i)} = 1, \sum_{j > i} U_j \tilde{V}_{ij} > 0) = \lambda p$. The second inequality in Equation (1.29) stems for the fact that $\bar{\mathcal{A}}(i) = \max(\mathcal{A}(i), \mathcal{A}^*(i))$, where $\mathcal{A}^*(i)$ is the ancestor of i in the dual point set: $U_i^* = 1 - U_i$. As in Equation (1.28), the tail of $\mathcal{A}^*(i) - i$ is equivalent to $(1 - p)t^{1-\beta}/(\beta - 1)$. For $t \geq 1$, a direct computation leads to $\mathbb{P}(\bar{P}(i) - P(i) \geq t) = \mathbb{P}(\mathcal{A}^*(i) - \mathcal{A}(i) \geq t) = \mathbb{P}(\sum_{j \geq t} (1 - U_{\mathcal{A}(i)+j}) \mathbf{1}(\tilde{V}_{0, \mathcal{A}(i)+j} \leq |\mathcal{A}(i) + j|^{-\beta}) > 0) \leq C_1 t^{2(1-\beta)}$, indeed on the event $\{U_j = 0\}$, V_j and \tilde{V}_j have the same distribution.

Let $X_0 = Y_0 = 0$, $Y_k = \bar{\mathcal{A}}(X_{k-1})$. \mathcal{F}_k is σ -algebra generated by the variables $(X_1, Y_1), \dots, (Y_k, X_k)$

Theorem 1.4.2 *If $\beta > 2$, \mathcal{A} is regenerative: there exists a.s. a $\{\mathcal{F}_k\}_{k \in \mathbb{N}}$ -stopping time $\theta \geq 1$ such that:*

$$N_{X_\theta} | \mathcal{F}_\theta \stackrel{\mathcal{L}}{=} N_0.$$

If $\beta > 3$, $\mathbb{E}\theta < \infty$.

This theorem may appear weird: the process X_k is anticipating but there exists a stopping time θ which guarantee a regenerative property. This paradox vanishes if we remind that θ is a stopping time with respect to the filtration *in time* \mathcal{F}_k and includes the variable Y_k which looks forward X_k *in space*. \mathcal{F}_k is thus the horizon of spatial anticipation at time k .

In order to prove Theorem 1.4.2, we will use a coupling between X and Y .

Lemma 1.4.3 *Assume that there exists an a.s. finite time $\theta \in \mathbb{N}^*$ such that*

$$X_\theta = \max_{k \leq \theta} Y_k,$$

then θ is a regenerative time.

Proof. Let $Z_n = \max_{k \leq n} Y_k$. By definition $Y_n = \sup\{j \in \mathbb{Z} : V_{X_n, j} \leq |i - j|^{-\beta}\}$ hence $Z_n = \sup\{j \geq Z_{n-1} : V_{X_n, j} \leq |i - j|^{-\beta}\}$.

Assume now that $X_\theta = Z_\theta, \theta \geq 1$: $N_{X_\theta} = \sum_{i \geq 1} U_{X_\theta+i} \delta_i = \sum_{i \geq 1} U_{Z_\theta+i} \delta_i$. Let $I = \{i_1, \dots, i_n\}$ be a finite subset in $\mathbb{N} \setminus \{0\}$ and $N(I) = \sum_{i \in I} U_i$. The smallest σ -algebra such that N_j is measurable is the σ -algebra generated by the collection $(N(j+I) = t), I \subset \mathbb{N} \setminus \{0\}, t \in \mathbb{N}$. It thus suffices to prove $\mathbb{P}(N(X_\theta + I) = t | \mathcal{F}_\theta) = \mathbb{P}(N(I) = t)$ for all finite subsets I of $\mathbb{N} \setminus \{0\}$ and $t \in \mathbb{N}$. To this end, we write:

$$\begin{aligned} \mathbb{P}(N(X_\theta + I) = t | \mathcal{F}_\theta) &= \mathbb{P}(N(Z_\theta + I) = t, \bigcap_{0 \leq l \leq \theta} \bigcap_{j \in I} \{V_{X_l, j+Z_\theta} > (j + Z_\theta - X_l)^{-\beta}\} | \mathcal{F}_\theta) \\ &= \mathbb{P}(N(Z_\theta + I) = t | \bigcap_{0 \leq l \leq \theta} \bigcap_{j \in I} \{V_{X_l, j+Z_\theta} > (j + Z_\theta - X_l)^{-\beta}\}, \mathcal{F}_\theta) \\ &= \mathbb{P}(N(I) = t) \end{aligned} \tag{1.31}$$

Equation (1.30) holds since for all $j > 0$, $\mathbb{P}(\bigcap_{0 \leq l \leq n} \{V_{X_l, j+Z_n} > (j + Z_n - X_l)^{-\beta}\}) = 1$ and Equation (1.31) comes from the fact that, given $\bigcap_{0 \leq l \leq n} \{V_{X_l, j+Z_n} > (j + Z_n - X_l)^{-\beta}\}$, U_{j+Z_n} is a Bernoulli variable with parameter p . \square

We need a natural definition to compare two point sets. Let $N^1 = \sum_{i \geq 1} U_i^1 \delta_i$ and $N^2 = \sum_{i \geq 1} U_i^2 \delta_i$ we say that $N^1 \stackrel{st}{\leq} N^2$ if for all finite subset of positive integers I and $t \in \mathbb{N}$: $\mathbb{P}(\sum_{i \in I} U_i^1 \geq t) \leq \mathbb{P}(\sum_{i \in I} U_i^2 \geq t)$.

Lemma 1.4.4

$$N_{X_k} | \mathcal{F}_k \stackrel{st}{\leq} N_0. \tag{1.32}$$

Proof. Let I be a subset of $\mathbb{N} \setminus \{0\}$, as in the proof of Lemma 1.4.3, we write:

$$\begin{aligned} \mathbb{P}(N(X_k + I) = t | \mathcal{F}_k) &= \mathbb{P}(N(X_\theta + I) = t, \bigcap_{0 \leq l \leq k} \bigcap_{j \in I} \{V_{X_l, j+X_k} > (j + X_k - X_l)^{-\beta}\} | \mathcal{F}_k) \\ &\leq \mathbb{P}(N(X_k + I) = t | \bigcap_{0 \leq l \leq k} \bigcap_{j \in I} \{V_{X_l, j+X_k} > (j + X_k - X_l)^{-\beta}\}, \mathcal{F}_k) \\ &\leq \mathbb{P}(N(I) = t), \end{aligned}$$

indeed, as already pointed, for $j > 0$ given $\bigcap_{0 \leq l \leq k} \{V_{X_l, j+X_k} > (j + X_k - X_l)^{-\beta}\}$, U_{j+X_k} is a Bernoulli variable with parameter p . \square

We can now prove Theorem 1.4.2.

Proof. Let $Z_n = \max_{k \leq n} Y_k$ and $W_n = Z_n - X_n \geq 0, W_0 = 0$. By Lemma 1.4.3 it suffices to prove that there exists a time $\theta \geq 1$ such that $W_\theta = 0$. We rewrite W_n as:

$$\begin{aligned}
W_n &= \max_{1 \leq i \leq n} (Y_i - X_n) \\
&= \max_{1 \leq i \leq n} ((Y_i - X_i) + (X_i - X_n)) \\
&= \max_{1 \leq i \leq n} ((Y_i - X_i) - \sum_{k=i}^{n-1} P_k),
\end{aligned}$$

(where by convention $\sum_{k=n}^{n-1} \cdot = 0$). We note that $P_k \geq 1$. Let $(\sigma_k)_{k \in \mathbb{N}}$ be a sequence of iid copies of variables with distribution Y_1 , we deduce:

$$W_n \stackrel{st}{\leq} \left(\max_{2 \leq i \leq n-1} (\sigma_{i-1} - \sum_{k=i-1}^{n-1} 1) \right)^+$$

That is W_n is upper bounded by the largest residual service time in a GI/GI/ ∞ queue (see Appendix C.2). By Lemma C.2: for $\beta > 2$, θ is a.s. finite, and for $\beta > 3$, $\mathbb{E}\theta < \infty$. \square

As a consequence of Theorem 1.4.2 we have the following:

Corollary 1.4.5 *If $\beta > 3$, there exists a constant $\mu > 0$ such that:*

$$\frac{\mathcal{A}^k(0)}{k} \rightarrow \mu.$$

Proof. Assume $\beta > 3$, by Theorem 1.4.2 there exists an increasing sequence $(\theta_n), n \in \mathbb{N}, \theta_0 = 0, \theta_1 = \theta, \theta_{n+1} - \theta_n$ is iid and $\mathbb{E}(\theta_{n+1} - \theta_n) < \infty$. This sequence satisfies: $N_{X_{\theta_n}} \stackrel{\mathcal{L}}{=} N_0$. We define:

$$P_k^\theta = X_{\theta_{k+1}} - X_{\theta_k} = \sum_{l=\theta_k}^{\theta_{k+1}-1} P_l.$$

The sequence $(P_k^\theta), k \in \mathbb{N}$, is iid.

$$\mathbb{P}(P_n \geq t | \mathcal{F}_n) \leq \mathbf{1}(t \geq W_n) \bar{F}(t) + \mathbf{1}(t < W_n). \quad (1.33)$$

As t tends to infinity, from Equation (1.28), we have $\bar{F}(t) = \mathbb{P}(P_0 \geq t) \sim \frac{p}{\beta-1} t^{1-\beta}$. It follows

$$\mathbb{E}P_0^\theta \leq \mathbb{E}\theta \mathbb{E}P_0 + \mathbb{E} \sum_{l=0}^{\theta-1} W_l < \infty.$$

Therefore, Corollary 1.4.5 follows from the strong of law of large numbers. \square

Our method fails for $\beta \in (1, 3)$. For example for $1 < \beta < 2$, we expect that $\mathcal{A}^k(0)$ is of order of magnitude $k^{1/(\beta-1)}$. Nevertheless, this approach paves the way to proofs of asymptotic results to directed navigation on PPP.

1.4.3 Directed Navigation on a Small World

In this paragraph, we extend the results established on the discrete lattice to Poisson Point Processes on \mathbb{R}^d . The method is exactly the same but the coupling is different.

We recall the model introduced in §1.1.5. The navigation graph if $\mathcal{G} = (N^0, E)$, N is PPP on \mathbb{R}^d . We mark N to obtain a marked point process: $\bar{N} = \sum_n \delta_{X_n, V_n}$, where $V_n = (V_{ni})_{i \in \mathbb{N}} \in$

$[0, 1]^{\mathbb{N}}$. For X, Y in N , we will write $V(X, Y)$ for V_{ni} where n and i are the index of X and Y . Let f be a measurable function from \mathbb{R}_+ to $[0, 1]$ such that for a constant $c > 0$ and $\beta > d$:

$$f(t) \sim_{t \rightarrow +\infty} \frac{c}{t^\beta}.$$

The Small World Graph is defined by:

$$(X, Y) \in E \text{ if } V(X, Y) \leq f(|X - Y|).$$

We fix a direction e_1 in S^{d-1} . The maximal progress navigation from $X \in N$ to 0 is defined as:

$$\mathcal{A}_{e_1}(X) = \arg \max\{\langle Y, e_1 \rangle : (X, Y) \in E\}.$$

We define $\mathcal{H}(X) = \{x \in \mathbb{R}^d : \langle x - X, e_1 \rangle > 0\}$, the directed progress is positive if $\mathcal{A}(X, e_1) \in \mathcal{H}(X)$. We assume that the marks $(V_{ij}), i < j, i, j \in \mathbb{N}$ are independent and uniformly distributed conditioned on the event: $\Omega = \{\forall X \in N : \int_{\mathcal{H}(X)} \mathbf{1}(V(X, x) \leq |x - X|^{-\beta}) N(dx) > 0\}$.

Let F be the distribution of the directed progress: $P_{e_1}(X) = \langle X, e_1 \rangle - \langle \mathcal{A}(X, e_1), e_1 \rangle$ (which does not depend on e_1). In this section $P_{e_1}(X)$ will be denoted for short by $P(X)$ and $P_k = P(X_k, e_1)$

The aim of this section is to prove the following theorem:

Theorem 1.4.6 *The following assertions holds:*

- If $\beta > d + 1$, \mathcal{A} is regenerative.
- If $\beta > d + 2$, there exists a constant $\mu > 0$ such that:

$$\frac{\langle \mathcal{A}^k(0), e_1 \rangle}{k} \rightarrow \frac{m}{u}.$$

The remaining part of this subsection is devoted to the proof of Theorem 1.4.6. The proof is analog to the proof in the lattice case.

Proof. The set of neighbors of X in G is denoted by $V(X)$. It is a thinning a N and $V(X)$ is a non-homogeneous Poisson point process with intensity: $f(|X - x|)dx$ conditioned on $\{V(X) \cap \mathcal{H}(X) \neq \emptyset\}$. In the next computation $\tilde{V}(X)$ will denote a PPP of intensity $f(|X - x|)dx$ obtained by an independent thinning of N . If A is a Borel set in $\mathcal{H}(X)$, $0 \notin A$ then $\mathbb{P}(\tilde{V}(X)(A) = 0) = \exp(-\int_A f(|X - x|)dx)$ and $\mathbb{P}(V(X)(A) = 0) = \mathbb{P}(\tilde{V}(X)(A) = 0) \mathbb{P}(\tilde{V}(X)(\mathcal{H}(X) \cap A^c) > 0) / \mathbb{P}(\tilde{V}(X)(\mathcal{H}(X)) > 0)$. We then write:

$$\begin{aligned} \mathbb{P}(N(A) = k | A \subset \mathcal{H}(X_1)) &= \mathbb{P}(\tilde{V}(X)(A) = 0 | N(A) = k) \mathbb{P}(N(A) = k) / \mathbb{P}(\tilde{V}(X)(A) = 0) \\ &= \left(1 - \frac{\int_A f(|X - x|)dx}{|A|}\right)^k \frac{|A|^k}{k!} \exp(-|A| + \int_A f(|X - x|)dx) \\ &= (|A| - \int_A f(|X - x|)dx)^k \frac{1}{k!} \exp(-|A| + \int_A f(|X - x|)dx). \end{aligned}$$

In other words: $N \cap \mathcal{H}(X_1)$ is a Poisson point process of intensity: $(1 - f(|X - x|))dx$. Since f tends to 0, far from X_1 , the distribution $N \cap \mathcal{H}(X_1)$ and $N \cap \mathcal{H}(0)$ are close. We formalized this idea with the next lemma.

Lemma 1.4.7 *For all X there exists a random variable $Y(X) \geq \langle X, e_1 \rangle + P(X)$ such that for all Borel sets A with $A \subset \mathcal{H}(Y(X)e_1)$, $t \in \mathbb{N}$:*

$$\mathbb{P}(N(A) = t | Y(X)) = \mathbb{P}(N(A) = t). \tag{1.34}$$

$$\mathbb{P}(Y(X) - \langle X, e_1 \rangle \geq t) \leq C_1 t^{d-\beta}. \tag{1.35}$$

This lemma states that there exists an a.s. finite length $Y(X)$ such that beyond $Y(X)$, N given X_1 is distributed as an homogeneous PPP.

Proof. $N \cap \mathcal{H}(X + P(X)e_1)$ is a PPP of intensity $(1 - f(|X - x|))dx$. We build a coupling to retrieve a PPP of intensity 1. Let $\tilde{V}(X)$ be a PPP with intensity $f(|X - x|)dx$ and independent of N . Since $\tilde{V}(X) \cap \mathcal{H}(X + P(X)e_1)$ and $N \cap \mathcal{H}(X + P(X)e_1)$ are independent: $(\tilde{V}(X) + N) \cap \mathcal{H}(X + P(X)e_1)$ is a PPP of intensity 1 on $\mathcal{H}(X + P(X)e_1)$. $\tilde{V}(X)$ is a.s. a finite point set. Let $\rho(X)$ be the radius of the smallest ball containing $\tilde{V}(X)$, we have:

$$\mathbb{P}(\rho(X) \geq t) = 1 - \exp\left(-\int_{B(0,t)^c} f(x)dx\right) \leq C_1 t^{d-\beta}.$$

We define:

$$Y(X) = \langle X, e_1 \rangle + \max(P(X), \rho(X)),$$

and clearly Equation (1.35) holds. If A is a Borel set in $\mathcal{H}(Y(X)e_1)$ then $(\tilde{V}(X) + N)(A) = N(A)$. Since $(\tilde{V}(X) + N) \cap \mathcal{H}(X + P(X)e_1)$ is a PPP of intensity 1, we deduce Equation (1.34). \square

We build a non-increasing sequence (Z_k) such that for $A \subset \mathcal{H}(Z_k e_1)$,

$$\mathbb{P}(N(A) = t | X_0, \dots, X_k, Z_k) = \mathbb{P}(N(A) = t). \quad (1.36)$$

We set $Z_1 = Y_1 = Y(X)$, from Lemma 1.4.7, given Z_1 , $N \cap \mathcal{H}(Z_1 e_1)$ is a PPP of intensity 1. $N \cap \mathcal{H}(X_2)$ is a thinning of N . Hence, given Z_1 and X_2 , $N \cap \mathcal{H}(\max(X_2, Z_1 e_1))$ is a PPP $(1 - f(|X_1 - x|))dx$. As in the proof of Lemma 1.4.7, let $\tilde{V}(X_1)$ be a PPP with intensity $f(|X_1 - x|)dx$ and independent of N . Let ρ_1 denotes the smallest ball which contains $\tilde{V}(X_1)$, and $Y_2 = \langle X_1, e_1 \rangle + \max(\rho_1, P_1)$. We define:

$$Z_2 = \max(Y_1, Y_2).$$

Equation (1.36) for $k = 2$. More generally we define iteratively, $Y_k = \max(\langle X_{k-1}, e_1 \rangle + \rho_{k-1}, \langle X_k, e_1 \rangle)$, and $Z_k = \max_{l \leq k} Y_l$. Equation (1.36) holds for this sequence. Let \mathcal{F}_k be σ -algebra generated by $((X_1, Y_1), \dots, (X_k, Y_k))$. Since ρ_k is independent of N we have

$$\mathbb{P}(Y_k - \langle X_k, e_1 \rangle \geq t | \mathcal{F}_k) \leq \mathbb{P}(\rho_k \geq t) \leq C_1 t^{d-\beta}. \quad (1.37)$$

The coupling we have build for a PPP on \mathbb{R}^d is different for the coupling that we have used on the \mathbb{Z} lattice. Let $N_X = N \cap \mathcal{H}(X) - X$. We endow the set of point processes of the natural partial order relation: $N_1 \stackrel{st}{\leq} N_2$ if for all Borel sets A and $t \in \mathbb{N}$, $\mathbb{P}(N_1(A) \geq t) \leq \mathbb{P}(N_2(A) \geq t)$. The next Lemma is similar to Lemma 1.4.4.

Lemma 1.4.8

$$N_{X_k} | \mathcal{F}_k \stackrel{st}{\leq} N_0 \quad (1.38)$$

and consequently for some $C_0 > 0$,

$$(i) \mathbb{P}(P_k \geq 1 | \mathcal{F}_k) \geq C_0. \quad .$$

$$(ii) \mathbb{P}(Y_k = \langle X_k, e_1 \rangle | \mathcal{F}_k) \geq C_0.$$

Proof. Equation (1.38) is a direct consequence of the fact that N_{X_k} is a non-homogeneous PPP of intensity $\prod_{l=0}^{k-1} (1 - f(|x + X_k - X_l|)) \leq 1$.

Assertion (i) stems from the fact that the progress is a.s. positive. Indeed, let $\mathcal{A}'(X) = \arg \min\{\langle Y, e_1 \rangle : Y \in N \cap \mathcal{H}(X), (X, Y) \in E\}$. The set of vertices in $V(X)$ is a.s. finite hence a.s. $\langle \mathcal{A}'(X) - X, e_1 \rangle > 0$. A direct computation shows that $\mathbb{P}(\langle \mathcal{A}'(0), e_1 \rangle > t)$ is positive for all

t . From Equation (1.38), there are stochastically fewer points in N_{X_k} given \mathcal{F}_k than in a PPP of intensity 1. We thus have the lower bound $\mathbb{P}(P_k \geq t | \mathcal{F}_k) \geq \mathbb{P}(\langle \mathcal{A}'(0), e_1 \rangle > t)$.

Statement (ii) follows from:

$$\mathbb{P}(Y_k = \langle X_k, e_1 \rangle | \mathcal{F}_k) \geq \mathbb{P}(\rho_k \leq 1) \mathbb{P}(P_k \geq 1 | \mathcal{F}_k) \geq C_0.$$

□

Note that Equation (1.37) and Statement (ii) in Lemma 1.4.8 imply that there exists a variable σ such that:

$$Y_k - X_k | \mathcal{F}_k \stackrel{st}{\leq} \sigma, \quad \mathbb{P}(\sigma = 0) > 0 \quad \text{and} \quad \mathbb{P}(\sigma \geq t) \leq C_1 t^{d-\beta}. \quad (1.39)$$

As in the lattice case, we define $W_n = Z_n - \langle X_n, e_1 \rangle \geq 0$, $W_0 = 0$. With the convention that inf over an empty set is $+\infty$, let $\theta_0 = 0$, $\theta_{n+1} = \inf\{k > \theta_n : W_k = 0\}$. We have:

$$W_n \leq \left(\max_{2 \leq i \leq n-1} (\sigma_{i-1} - \sum_{k=i-1}^{n-1} \tau_k) \right)^+,$$

where $(\sigma_k)_{k \in \mathbb{N}}$ is a sequence of iid copies of σ given in Lemma 1.4.7 and $(\tau_k)_{k \in \mathbb{N}}$ is a sequence of iid copies of τ with $\mathbb{P}(\tau = 1) = 1 - \mathbb{P}(\tau = 0) = C_0$, as in Lemma 1.4.8, Assertion (i). W_n is upper bounded by the largest residual service time in a GI/GI/ ∞ queue (see Appendix C.2). The remainder of the proof is then as in Corollary 1.4.5. □

1.4.4 Navigation in a Small World

Main Result

We continue our analysis to the model 2 introduced in §1.1.5. As in the §1.4.3, let F be the distribution of the directed progress: $P_{e_1}(X) = \langle X, e_1 \rangle - \langle \mathcal{A}(X, e_1), e_1 \rangle$ and F_X the distribution of the progress $P(X) = |X| - |\mathcal{A}(X)|$. Let $H(X)$ be the generation of X that is: $H(X) = \inf\{k \geq 0 : \mathcal{A}^k(X) = 0\}$. Let $X_k = \mathcal{A}^k(X)$ and $P_k = P(X_k) = |X_k| - |X_{k+1}|$.

Theorem 1.4.9 - *If $\beta > d + 1$, \mathcal{A} is regenerative.*

- *If $\beta > d + 2$ and μ as in Theorem 1.4.6 a.s.*

$$\lim_{|X| \rightarrow \infty} \frac{H(X)}{|X|} = \frac{1}{\mu}.$$

- *If $\beta = d$, a.s. and $\tilde{\mu}$ as in Lemma 1.2.6 a.s.*

$$\lim_{|X| \rightarrow \infty} \frac{H(X)}{\ln |X|} = \frac{1}{\tilde{\mu}}.$$

- *If $d - 2 < \beta < d$, a.s.*

$$\lim_{|X| \rightarrow \infty} \frac{H(X)}{\ln \ln |X|} = -\frac{1}{\ln(1 - \frac{d-\beta}{2})}.$$

In view of Lemma 1.2.6 this theorem is of the same type than the convergence results we have proved in the PWIT. The *PWIT approximation* gives the exact order of magnitude for $H(X)$. It is also worth to mention that our method has enabled us to determine the exact asymptotic limit for $\beta \in (d - 2, d]$.

Proof of Theorem 1.4.9: $\beta > d$

Step One: Regenerative Sequence

For $\beta > d + 2$, we build a sequence (θ_n) of stopping time on an enlarged filtration of (X_0, \dots, X_n) . The proof is close to the proof of Theorem 1.4.6. We will only focus on the differences.

Lemma 1.4.10 *For all X there exists a random variable $0 \leq Y(X) \leq |X| - P(X)$ such that for all Borel sets A with $A \subset B(0, Y(X))$, $t \in \mathbb{N}$:*

$$\mathbb{P}(N(A) = t | Y(X)) = \mathbb{P}(N(A) = t). \quad (1.40)$$

Moreover for all X :

$$\mathbb{P}(|X| - Y(X) \geq t) \leq C_1 t^{d-\beta}. \quad (1.41)$$

$N \cap B(0, X_1)$ is a Poisson point process of intensity: $(1 - f(|X - x|))dx$ (under its Palm version at 0). The proof uses the same coupling than Lemma 1.4.7.

Proof. Let $\tilde{V}(X)$ be a PPP with intensity $f(|X - x|)dx$ and independent of N . Since $\tilde{V}(X) \cap B(0, |X| - P(X))$ and $N \cap B(0, |X| - P(X))$ are independent: $(\tilde{V}(X) + N) \cap B(0, |X| - P(X))$ is a PPP of intensity 1 on $B(0, |X| - P(X))$ in its Palm version at 0. $\tilde{V}(X)$ is a.s. a finite point set. Let $\rho(X)$ be the radius of the smallest ball containing $\tilde{V}(X)$, we have for a some $C_1 > 0$ (not depending on X):

$$\mathbb{P}(\rho(X) \geq t) = 1 - \exp\left(-\int_{B(0,t)^c} f(x)dx\right) \leq C_1 t^{d-\beta}.$$

We then define: $Y(X) = (|X| - \max(P(X), \rho(X)))^+$. □

Let ρ_k denote the smallest ball which contains $\tilde{V}(X_k)$, where $\tilde{V}(X_k)$ is a PPP with intensity $f(|X_k - x|)dx$ and independent of N . We define $Y_0 = |X|$ and $Y_k = (\min(|X_{k-1}| - \rho_k, |X_k|))^+$ and \mathcal{F}_k be σ -algebra generated by $(X_1, Y_1), \dots, (X_k, Y_k)$, Let $Z_0 = |X|$ and

$$Z_k = \min(Z_{k-1}, |X_{k-1}| - \rho_k, |X_k|) = \min_{0 \leq l \leq k} Y_l.$$

For $A \subset B(0, Z_k)$, we have:

$$\mathbb{P}(N(A) = t | \mathcal{F}_k) = \mathbb{P}(N(A) = t). \quad (1.42)$$

The next lemma is the analog of Lemma 1.4.8.

Lemma 1.4.11 *For all Borel set $A \subset B(0, |X_k|)$, $t \in \mathbb{N}$:*

$$\mathbb{P}(N(A) \geq t | \mathcal{F}_k) \leq \mathbb{P}(N(A) \geq t). \quad (1.43)$$

and consequently:

$$(i) \text{ if } |X_k| \geq 2, \mathbb{P}(P_k \geq 1 | \mathcal{F}_k) \geq C_0,$$

$$(ii) \text{ if } |X_k| \geq 2, \mathbb{P}(X_{k+1} = Y_{k+1} | \mathcal{F}_k) \geq C_0.$$

Proof. We omit most the proof which is similar to the proof of Lemma 1.4.8. We only explain statement (i). Let $\mathcal{A}'(X) = \arg \max\{|Y| : Y \in N \cap B(0, |X|), (X, Y) \in E\}$. The progress is a.s. positive and the set of vertices in $V(X)$ is a.s. finite. Hence $|X| - |\mathcal{A}'(X)| > 0$ and a direct computation shows that $\mathbb{P}(|X| - |\mathcal{A}'(X)| \geq 1) \geq \mathbb{P}(V(X) \cap (B(0, |X|) \setminus B(0, |X| - 1)) = \emptyset) > C_0$ for $|X| \geq 2$. From Equation (1.43), there are stochastically fewer points in $N \cap B(0, |X_k|)$ given

\mathcal{F}_k than in a PPP of intensity 1. We thus have the lower bound, for all $t \geq 0$ $\mathbb{P}(P_k \geq t | \mathcal{F}_k) \geq \mathbb{P}(|X| - |\mathcal{A}'(X)| \geq t | X = X_k)$. \square

Since ρ_k and X_k are independent, $\mathbb{P}(|X_k| - Y_k \geq t | \mathcal{F}_k) \leq \mathbb{P}(\rho_k \geq t) \leq C_1 t^{d-\beta}$. This last equation and statement (ii) in Lemma 1.4.11 imply that there exists a variable σ such that, if $|X| \geq 2$:

$$(Y_k - X_k) | \mathcal{F}_k \stackrel{st}{\leq} \sigma, \quad \mathbb{P}(\sigma = 0) > 0 \quad \text{and} \quad \mathbb{P}(\sigma \geq t) \leq C_1 t^{d-\beta}. \quad (1.44)$$

Exactly as in the lattice case, we define $W_n = |X_n| - Z_n \geq 0$, $W_0 = 0$ and for $n \geq H(X)$, $W_n = 0$. We have:

$$W_n \stackrel{st}{\leq} \left(\max_{2 \leq i \leq n-1} (\sigma_{i-1} - \sum_{k=i-1}^{n-1} \tau_k) \right)^+, \quad (1.45)$$

where $(\sigma_k)_{k \in \mathbb{N}}$ is a sequence of iid copies of σ given in Equation (1.44) and $(\tau_k)_{k \in \mathbb{N}}$ is a sequence of iid copies of τ with $\tau = 1$ with probability C_0 and 0 otherwise, as in Lemma 1.4.11.

By Equation (1.45), W_n is upper bounded by the largest residual service time in a GI/GI/ ∞ queue (see Appendix C.2). Let \tilde{W}_n be the right hand side of Equation (1.45) and $\theta = \inf\{k \geq 1 : \tilde{W}_k = 0\}$. By Lemma C.2 (in Appendix): if $\beta > d + 1$, θ is a.s. finite and if $\beta > d + 2$: $\mathbb{E}\theta < \infty$. By Equation (1.42), θ is a regenerative time for the the small world navigation.

Step Two: Embedded memoryless navigation

\mathcal{A}^θ is a memoryless navigation (for $|X| \geq 2$). We define:

$$P^\theta(X) = |X| - |X_\theta| = \sum_{k=0}^{\theta-1} P_k.$$

$$\mathbb{P}(P_k \geq t | \mathcal{F}_k) \leq \bar{F}_X(t) \mathbf{1}(t \geq W_k) + \mathbf{1}(t < W_k), \quad (1.46)$$

where $W_k \stackrel{st}{\leq} M$, $\mathbb{P}(M \geq t) \leq C_1 t^{1-(\beta-d)}$ and $\bar{F}_X(t) \leq C_1 t^{d-\beta}$. If $(U_k)_{k \in \mathbb{N}}$ denotes an iid sequence of variables such that $\mathbb{P}(U_k \geq t) = 1 \wedge C_1 t^{\beta-d}$ with U_k independent of \mathcal{F}_k , we have from Equation (1.46):

$$P^\theta(X) \stackrel{st}{\leq} Q = \sum_{k=0}^{\theta-1} (U_k + W_k).$$

We have $\mathbb{E}Q = \mathbb{E}\theta \mathbb{E}U + \mathbb{E} \sum_0^\theta W_k < \infty$ (from cycle formula, see Baccelli and Brémaud §3.1 [20]). It follows also that $(P^\theta(X))_{X \in \mathbb{R}^d}$ is uniformly integrable.

The next step is to identify $\lim_{|X| \rightarrow \infty} \mathbb{E}P^\theta(X)$. For the directed navigation with direction e_1 , the same regenerative time θ was defined and Theorem 1.4.6 gives:

$$\mathbb{E}P_{e_1}^\theta(0) = \mu \mathbb{E}\theta.$$

$P_{e_1}^\theta(X)$ is a stabilizing functional of the small world graph and the distribution of $P_{e_1}^\theta(0)$ does not depend on e_1 . Hence from Theorem 1.2.3, $P^\theta(X)$ converges weakly to $P_{e_1}^\theta(0)$. Since $(P^\theta(X))_{X \in \mathbb{R}^d}$ is uniformly integrable, we obtain:

$$\lim_{|X| \rightarrow \infty} \mathbb{E}P^\theta(X) = \mathbb{E}P_{e_1}^\theta(0) = \mu \mathbb{E}\theta.$$

Thus we can apply Proposition 1.3.6 and Lemma 1.4.1 and we deduce that $H(X)/|X|$ tends a.s. to $1/\mu$.

Proof of Theorem 1.4.9: $\beta = d$

We define the scaled free progress as $\tilde{P}_k = -\ln(1 - P_k/|X_k|)$. We have $\ln|X_k| = \ln|X| - \sum_{i=0}^{k-1} \tilde{P}_i$. We follow step by step the proof of the case $\beta > d$ with a major difference: we need to consider scaled variables. We need also to be careful with the event $\{\tilde{P}(X) = \infty\} = \{P(X) = |X|\}$: in this paragraph, we will use the convention " $\ln \frac{0}{0} = 0$ ". We define $Y(X) = \min(|\mathcal{A}(X)|, \sup\{t : B(0, t) \cap \tilde{V}(X) = \emptyset\})$, where $\tilde{V}(X)$ is a PPP intensity $f(|x - X|)$ and independent of everything else, as in Lemma 1.4.10 we obtain:

Lemma 1.4.12 *There exists a random variable $0 \leq Y(X) \leq |\mathcal{A}(X)|$ such that for all Borel sets A with $A \subset B(0, Y(X))$, $t \in \mathbb{N}$:*

$$\mathbb{P}(N(A) = t | Y(X)) = \mathbb{P}(N(A) = t).$$

Moreover for all X :

$$\mathbb{P}(\ln \frac{|\mathcal{A}(X)|}{Y(X)} \geq s | Y(X) > 0) \leq C_1 \exp(-2s).$$

We define the sequence (Y_k) and (Z_k) as previously. Equation (1.42) still holds, and the analog of Lemma 1.4.11 reads:

Lemma 1.4.13 *For all Borel sets $A \subset B(0, |X_k|)$, $t \in \mathbb{N}$:*

$$\mathbb{P}(N(A) \geq t | \mathcal{F}_k) \leq \mathbb{P}(N(A) \geq t).$$

At this point of the proof an obstacle shows up, $\mathbb{P}(P_k \geq 1 | \mathcal{F}_k) \geq C_0 > 0$ does not implies the same statement on the scaled progress \tilde{P}_k . To circumvent this problem, we define the event:

$$\Omega_\epsilon = \{\forall X \in \mathbb{R}^d : N^0 \cap B(0, |X|) \geq \epsilon |X|^d\}.$$

It is easy to check that $\mathbb{P}(\Omega_\epsilon) > 0$ for $\epsilon < \epsilon_0$ and $\lim_{\epsilon \rightarrow 0+} \mathbb{P}(\Omega_\epsilon) = 1$.

Let $\mathbb{P}_\epsilon(\cdot)$ denote the conditional probability given Ω_ϵ . Under \mathbb{P}_ϵ , Lemmas 1.4.12 and 1.4.13 still hold. Moreover since a point in $B(0, t|X|)$ is at most at distance $(1+t)|X|$ of $|X|$, we have:

$$\begin{aligned} \mathbb{P}_\epsilon(\tilde{P}_k \geq 1 | \mathcal{F}_k) &= \mathbb{P}(P_k \geq |X_k| e^{-1} | \mathcal{F}_k) \\ &\geq 1 - (1 - (1 - f((1 + e^{-1})|X|)))^{\epsilon |X|^d} \\ &\geq 1 - \exp(-\epsilon |X|^d f((1 + e^{-1})|X|)), \end{aligned}$$

where we have used the assumption that f is non-increasing. Then, since $f(t) \sim ct^{-d}$ we deduce that there exists x_0 such that for all $X \in \mathbb{R}^d$, $|X| \geq x_0$:

$$\mathbb{P}_\epsilon(\tilde{P}_k \geq 1 | \mathcal{F}_k) \geq C_\epsilon.$$

Similarly, by Lemma 1.4.12 and 1.4.13, there exists a r.v. σ such that:

$$P_\epsilon(\ln \frac{|X_{k+1}|}{Y_{k+1}} \geq s | \mathcal{F}_k, Y_{k+1} > 0) \leq \mathbb{P}(\sigma \geq s) \quad \text{with} \quad \mathbb{P}_\epsilon(\sigma = 0) > 0 \quad \text{and} \quad \mathbb{P}_\epsilon(\sigma \geq s) \leq C_1 \exp(-2s). \quad (1.47)$$

We define $H'(X) = \inf\{k \geq 0, Y_k = 0\}$. $H(X)/\ln|X|$ converges a.s. is equivalent to $H'(X)/\ln|X|$ converges a.s.. Indeed ρ_k is independent of X_k and $|X_{H'(X)}| \leq \rho_{H'(X)}$, hence $|H'(X) - H(X)| \leq N(B(0, \rho_{H'(X)}))$. For $n \leq H'(X)$, $W_n = \ln(|X_n|/Z_n) \geq 0$, we have

$$W_{n+1} = \max(W_n - \ln \frac{|X_n|}{|X_{n+1}|}, \ln \frac{|X_{n+1}|}{Y_{n+1}}),$$

and it follows

$$W_n \stackrel{st}{\leq} \left(\max_{2 \leq i \leq n-1} (\sigma_{i-1} - \sum_{k=i-1}^{n-1} \tau_k) \right)^+, \quad (1.48)$$

where $(\sigma_k)_{k \in \mathbb{N}}$ is a sequence of iid copies of σ given in Equation (1.47) and $(\tau_k)_{k \in \mathbb{N}}$ is a sequence of iid copies of τ with $\mathbb{P}_\epsilon(\tau \geq 1) \geq C_\epsilon$. W_n is upper bounded by the largest residual service time in a GI/GI/ ∞ queue (see Appendix C.2). Let θ be the first positive time at which the queue appearing on the left hand side of Equation (1.48) is empty. By Lemma C.1 (in Appendix): θ is a.s. finite and for some $C_\epsilon > 0$:

$$\mathbb{E}_\epsilon \exp(C_\epsilon \theta) < \infty. \quad (1.49)$$

We define $\tilde{P}^\theta(X) = \sum_{k=0}^{\theta-1} \tilde{P}_k$. Using Equations (1.49), (1.46) and Lemma 1.2.6, we deduce that for all $0 < \epsilon < \epsilon_0$, $(\mathbf{1}(\tilde{P}^\theta(X) < \infty) \tilde{P}^\theta(X))_{X \in \mathbb{R}^d}$ is uniformly integrable. We assume for the while that \tilde{P}^θ converges weakly and we define $\tilde{\mu}_\epsilon = \lim_{|X| \rightarrow \infty} \mathbb{E}_\epsilon \tilde{P}^\theta(X) / \mathbb{E}_\epsilon(\theta)$. From Proposition 1.3.12 we obtain

$$\mathbb{P}_\epsilon - a.s. \quad \lim_{|X| \rightarrow \infty} \frac{H(X)}{\ln |X|} = \frac{1}{\tilde{\mu}_\epsilon},$$

Since $\Omega_\epsilon \subset \Omega_{\epsilon'}$ for $\epsilon > \epsilon'$, $\tilde{\mu}_\epsilon$ does not depend on ϵ , and we drop the ϵ in its expression, $\tilde{\mu}_\epsilon = \tilde{\mu}'$. Notice also that $\{\Omega_{1/n}\}_{n \in \mathbb{N}}$ is an increasing sequence of events and $\cup_n \Omega_{1/n} = \Omega$, so finally

$$\mathbb{P} - a.s. \quad \lim_{|X| \rightarrow \infty} \frac{H(X)}{\ln |X|} = \frac{1}{\tilde{\mu}'},$$

It remains to prove that \tilde{P}^θ converges weakly. For simplicity, we will only consider Model 3, with obvious change, the proof applies also to Model 2. We cannot apply Theorem 1.2.3 and instead we prove this fact directly. Let $\tilde{F}_{k,X}$ denote the distribution of $\tilde{P}_k(X)$. Lemma 1.2.6 asserts that $\tilde{F}_{0,X}$ converges weakly to \tilde{F} given by Equation (1.9). As already pointed, $N \cap B(0, |X_1|)$ is a Poisson Point process of intensity $\lambda_{X_0}(y) dy = (1 - f(|X_0 - y|)) dy$. We thus have

$$\mathbb{P}(\tilde{P}_1(X) \geq s | \mathcal{F}_1) = 1 - (1 - f(|X_1|)) \exp\left(- \int_{B(0, |X_1| e^{-s})} f(|X_1 - y|) \lambda_{X_0}(y) dy\right),$$

with the change of variable $z = y/|X_1|$ and $e_i = X_i/|X_i|$, we end up with:

$$\mathbb{P}(\tilde{P}_1(X) \geq s | \mathcal{F}_1) = 1 - (1 - f(|X_1|)) \exp\left(- \int_{B(0, e^{-s})} |X_1|^d f(|X_1| |e_1 - z|) (1 - f(|X_1| |e_0 e^{\tilde{P}_0} - z|)) dz\right),$$

Since $|X_1| = |X| e^{-\tilde{P}_0}$, $\mathbb{P}(\tilde{P}_0(X) + \tilde{P}_1(X) \geq s)$ is equal to:

$$1 - \mathbb{E}(1 - f(|X| e^{-\tilde{P}_0})) \exp\left(- \int_{B(0, e^{-s - \tilde{P}_0})} e^{-d\tilde{P}_0} |X|^d f(e^{-\tilde{P}_0} |X| |e_1 - z|) (1 - f(|X| |e_0 - z e^{-\tilde{P}_0}|)) dz\right),$$

Letting $|X|$ tends to infinity and finally we deduce that:

$$\tilde{P}_0(X) + \tilde{P}_1(X) \Rightarrow \tilde{Q}_0 + \tilde{Q}_1,$$

where $(\tilde{Q}_k)_{k \in \mathbb{N}}$ is an iid sequence of variables with common distribution function \tilde{F} . Similarly for all $n \in \mathbb{N}$ we have:

$$\sum_{k=0}^{n-1} \tilde{P}_k(X) \Rightarrow \sum_{k=0}^{n-1} \tilde{Q}_k.$$

From Wald's Formula, $\mathbb{E}_\epsilon \sum_{k=0}^{\theta-1} \tilde{Q}_k = \mathbb{E}_\epsilon \theta \mathbb{E} \tilde{Q}_1$. Since the sequence $(\sum_{k=0}^{\theta-1} \tilde{P}_k(X))$ is uniformly integrable we deduce that $\lim_{|X| \rightarrow \infty} \mathbb{E} \sum_{k=0}^{\theta-1} \tilde{P}_k(X) = \mathbb{E}_\epsilon \theta \mathbb{E} \tilde{Q}_1$ and it follows

$$\tilde{\mu} = \tilde{\mu}'.$$

Proof of Theorem 1.4.9: $d - 2 < \beta < d$

The proof follows from Proposition 1.3.13 and the argument used in the case $\beta = d$. Let $\alpha = 1 - (d - \beta)/2$, we define for $1 \leq k \leq H(X)$, $U_k = |X_k|/|X_{k-1}|^\alpha$ and $U_k = 0$ for $k > H(X)$.

Let $\rho_k = |X_k| - \sup\{t : B(0, t) \cap \tilde{V}(X_k) = \emptyset\}$, where $\tilde{V}(X_k)$ is a PPP intensity $f(|x - X_k|)$ and independent of everything else. We define the sequences (Y_k) and (Z_k) as usual : $Y_k = \min((|X_{k-1}| - \rho_{k-1})^+, |X_k|)$ and $Z_k = \min_{k \leq l} Y_l$. Let $s > 0$, we have:

$$\begin{aligned} \mathbb{P}(\ln \frac{|X_1|}{|Y_1|} \geq s | Y_1 > 0) &\leq \mathbb{P}(\ln \frac{|X_1|}{(|X| - \rho_0)^+} \geq s | Y_1 > 0) \\ &\leq \mathbb{P}(\ln U_1 - \ln \frac{(|X| - \rho_0)^+}{|X|^\alpha} \geq s | Y_1 > 0) \\ &\leq \mathbb{P}(|\ln U_1| \geq s | X_1 \neq 0) + \mathbb{P}(|\ln \frac{|X| - \rho_0}{|X|^\alpha}| \geq s | \rho_0 < |X|) \\ &\leq C_1 \exp(-C_0 s^2). \end{aligned}$$

Let $H'(X) = \inf\{k \geq 1 : Y_k = 0\}$ and $W_n = \ln(|X_n|/Z_n) \geq 0$. The remainder of the proof is as in §1.4.4 with obvious changes.

1.4.5 Decentralized Navigation

How to prove that a navigation is regenerative ?

In this paragraph we generalize the coupling method used in the small world graph to other navigation. We will only explain under which type of conditions our method applies to other navigation schemes. We consider a navigation \mathcal{A} on a PPP N which satisfies the hypothesis of Theorem 1.2.3. The associated directed navigation is denoted by \mathcal{A}_{e_1} , and we assume that the distribution of $P_{e_1}(0) = \langle \mathcal{A}_{e_1}(0) - 0, e_1 \rangle$ does not depend on e_1 (the directed progress distribution is isotropic). We define $H(X) = \inf\{k : \mathcal{A}^k(X) = 0\}$ and as usual our aim is to prove that a.s.

$$\frac{H(X)}{|X|} = \frac{1}{\mu},$$

with $\mu = \lim_{k \rightarrow \infty} \frac{\mathbb{E}\langle \mathcal{A}_{e_1}^k(0), e_1 \rangle}{k} \in (0, +\infty)$. To do so, we will try to answer the following question:

Under which conditions a navigation is regenerative ?

Step One : Regenerative time on the directed navigation.

We define $X_0 = 0$ and $X_k = \mathcal{A}_{e_1}^k(0)$, $P_{e_1, k} = P_{e_1}(X_k)$. Let $E(X) = (X, \mathcal{A}_{e_1}(X))$ be the edge vector and $E_k = E(X_k)$. $\mathcal{H}(X) = \{Y : \langle Y - X, e_1 \rangle > 0\}$ and $N_X = N \cap \mathcal{H}(X) - X$.

The first assumption is:

- (i) If N_0 is a PPP of intensity $\lambda(x)dx$, $N_{\mathcal{A}_{e_1}(0)}$ is a PPP of intensity $(1 - \phi_{E(0)}(x))\lambda(x - \mathcal{A}_{e_1}(0))$, with $x \mapsto \phi_{E(0)}(x)$ measurable and taking value in $[0, 1]$.

Let $Y_0 = 0$ and $\mathcal{F}_0 = \sigma\{X_0, Y_0\}$, by induction we define a non-decreasing sequence Y_k and a filtration \mathcal{F}_k . Let $\tilde{V}(0)$ be a PPP with intensity $\phi_{E_0}(x)dx$ and independent of N given E_0 . Then $(\tilde{N}^0 + N_{X_1})$ is a PPP of intensity 1 on $\mathcal{H}(0)$. Our coupling method will only work if $\tilde{V}(0)$ is an a.s. finite set. We will assume for each k :

- (ii) For some $\alpha > 2$, $\mathbb{E}((\int_{\mathcal{H}(0)} \phi_{E_k}(x)dx)^\alpha | \mathcal{F}_k) \leq C_1$.

From assumption (ii), $\tilde{V}(0)$ is a.s. a finite point set. Let ρ_0 be the radius of the smallest ball containing $\tilde{V}(0)$, we have:

$$\mathbb{P}(\rho_0 \geq t) = 1 - \mathbb{E} \exp\left(- \int_{B(0,t)^c \cap \mathcal{H}(0)} \phi_{E_0}(x) dx\right) \leq C_1 t^{-\alpha}.$$

We define:

$$Y_1 = \max(\langle X_0, e_1 \rangle + \rho_0, \langle X_1, e_1 \rangle) \quad \text{and} \quad \mathcal{F}_1 = \mathcal{F}_0 \vee \sigma\{X_1, Y_1\}.$$

Using Assumption (ii), we have, for $t > 0$:

$$\mathbb{P}(Y_1 - \langle X_1, e_1 \rangle > t) \leq \mathbb{P}(\rho_0 > t) \leq C_1 t^{-\alpha}$$

Similarly

$$\mathbb{P}(Y_1 = \langle X_1, e_1 \rangle) \geq \mathbb{E} \exp\left(- \int_{\mathcal{H}(0)} \phi_{E_0}(x) dx\right) \geq \exp(-C_1) = C_0.$$

Now if A is a Borel set in $\mathcal{H}(Y_1 e_1)$ then $(S_{X_1} \tilde{V}(0) + N)(A) = N(A)$ where $S_x N = \sum_n \delta_{T_n+x}$ if $N = \sum_n \delta_{T_n}$. Since $(\tilde{V}(0) + N_{X_1}) \cap \mathcal{H}(Y_1 e_1 - X_1)$ is a PPP of intensity 1, we deduce:

$$N_{Y_1 e_1} | \mathcal{F}_1 \stackrel{\mathcal{L}}{=} N_0.$$

Assume now that we have built a sequence $(Y_k)_{0 \leq k \leq n-1}$ and a filtration $(\mathcal{F}_k)_{0 \leq k \leq n-1} = \bigvee_{k=0}^{n-1} \sigma\{X_k, Y_k\}$ such that for all $k \leq n-1$:

$$N_{Z_k e_1} | \mathcal{F}_k \stackrel{\mathcal{L}}{=} N_0 \quad \text{with} \quad Z_k = \max_{0 \leq l \leq k} Y_l. \quad (1.50)$$

$$0 \leq (Y_k - \langle X_k, e_1 \rangle) | \mathcal{F}_k \stackrel{st}{\leq} \sigma \quad \text{with} \quad \mathbb{P}(\sigma > t) \leq C_1 t^{-\alpha} \quad \text{and} \quad \mathbb{P}(\sigma = 0) > C_0. \quad (1.51)$$

From Assumption (i), N_{X_n} is a PPP of intensity $\lambda_n(x) dx$ where:

$$\lambda_n(x) = (1 - \phi_{E_n}(x)) \lambda_{n-1}(x - X_n + X_{n-1}) = \prod_{k=0}^n (1 - \phi_{E_k}(x - X_n + X_k)).$$

Let $\tilde{V}(n-1)$ be a PPP with intensity $\phi_{E_n}(x) \lambda_{n-1}(x - X_n + X_{n-1}) dx$ and independent of N given (E_n, \mathcal{F}_{n-1}) . $(\tilde{V}(n-1) + N) \cap \mathcal{H}(X_n)$ is a PPP of intensity $\lambda_{n-1}(x - X_n + X_{n-1}) dx$. We define ρ_{n-1} as the radius of the smallest ball containing $\tilde{V}(n-1)$ and:

$$Y_n = \max(\langle X_{n-1}, e_1 \rangle + \rho_{n-1}, \langle X_n, e_1 \rangle) \quad \text{and} \quad \mathcal{F}_n = \mathcal{F}_{n-1} \vee \sigma\{X_n, Y_n\}.$$

Since $\lambda_{n-1} \leq 1$, we check as we did for $k=1$ that the tail inequality in Equation (1.51) holds for $k=n$. Moreover we have:

$$\mathbb{P}(Y_n = \langle X_n, e_1 \rangle | \mathcal{F}_{n-1}) \geq \mathbb{E} \exp\left(- \int_{\mathcal{H}(0)} \phi_{E_{n-1}}(x) dx\right) | \mathcal{F}_{n-1} \geq C_0.$$

Equation (1.50) follows also from the same reasoning. Indeed assume that A is a Borel set in $\mathcal{H}(Z_n e_1)$ then $(S_{X_n} \tilde{V}(n-1) + N)(A) = N(A)$ and we conclude as we did for $n=1$.

Step Two : Embedded memoryless directed navigation.

At this point, we introduce a new assumption:

(iii) For some positive constants C_0, C_1 : $\mathbb{P}(P_{e_1, k} \geq C_1 | \mathcal{F}_k) \geq C_0$

We then have built a sequence $(Y_k)_{0 \leq k \leq n-1}$ satisfying Equations (1.50) and (1.51). As usual, we define $W_n = \langle X_n, e_1 \rangle - Z_n \geq 0$, and let $\theta = \inf\{k \geq 1 : W_k = 0\}$ (with the convention that \inf over an empty set is $+\infty$). We have:

$$W_n \stackrel{st}{\leq} \left(\max_{2 \leq i \leq n-1} (\sigma_{i-1} - \sum_{k=i-1}^{n-1} \tau_k) \right)^+,$$

where $(\sigma_k)_{k \in \mathbb{N}}$ is a sequence of iid copies of σ and $(\tau_k)_{k \in \mathbb{N}}$ is a sequence of iid copies of τ with $\mathbb{P}(\tau = C_1) = C_0$ and $\mathbb{P}(\tau = 0) = 1 - C_0$, as it is given by Assumption (iii). By Lemma C.2 (in Appendix): θ is a.s. finite and $\mathbb{E}\theta < \infty$. The directed navigation is thus regenerative, let $P_{e_1}^\theta(0) = \sum_{k=0}^{\theta-1} P_{e_1, k}$, from the strong law of large numbers, a.s.

$$\frac{\langle \mathcal{A}_{e_1}^k(0), e_1 \rangle}{k} \rightarrow \mu \quad \text{where} \quad \mu = \mathbb{E}P_{e_1}^\theta(0)/\mathbb{E}\theta.$$

Note at this point that μ is positive but may be infinite.

Step Three: Navigation

Now we turn back to the navigation from X to 0, $X_0 = X$, $X_k = \mathcal{A}(X)^k$ and $P_k = X_{k+1} - X_k$. $N^{0, X}$ is a PPP in its Palm version at $(0, X)$. We assume that the set of assumptions (i), (ii) and (iii) extends to the navigation as well:

(i') If $N \cap B(0, |X|)$ is a PPP of intensity $\lambda(x)dx$, $N \cap B(0, |\mathcal{A}(X)|)$ is a PPP of intensity $(1 - \phi_{E(X)}(x))\lambda(x - \mathcal{A}(X) + X)$.

(ii') $\mathbb{E}((\int_{B(0, |X|)} \phi_{E_k}(x)dx)^\alpha | \mathcal{F}_k) \leq C_1$.

(iii') For $|X| \geq x_0$, $\mathbb{P}(P_k \geq C_1 | \mathcal{F}_k) \geq C_0$.

As we previously did, we define by iteration $Y_0 = |X|$ and $Y_k = \min(|X_{k-1}| - \rho_k, |X_k|)$, where ρ_k is the radius of the smallest ball containing $\tilde{V}(k-1)$ a PPP with intensity $\phi_{E_k}(x)\lambda_{k-1}(x - X_k + X_{k-1})dx$ and independent of N given (E_k, \mathcal{F}_{k-1}) . Let $Z_k = \min(Z_{k-1}, Y_k) = \min_{0 \leq l \leq k} Y_l$ and $W_n = |X_n| - Z_n$. As long as $|X| \geq x_0$, $W_n \stackrel{st}{\leq} (\max_{2 \leq i \leq n-1} (\sigma_{i-1} - \sum_{k=i-1}^{n-1} \tau_k))$, we define θ as the first positive time at which the GI/GI/ ∞ queue is empty. By Lemma C.2 (in Appendix), $\mathbb{E}\theta < \infty$. We have proved that the navigation is regenerative. Then we introduce:

$$P^\theta(X) = |X| - |X_\theta| = \sum_{k=0}^{\theta-1} P_k.$$

From Theorem 1.2.3, $P^\theta(X)$ converges weakly to $P_{e_1}^\theta(0)$. The following assumption guarantee that the convergence holds also in L^1

(iv) $P^\theta(X)$ is uniformly integrable.

It remains to apply Proposition 1.3.6 and Lemma 1.4.1, we finally obtain:

$$a.s. \quad \frac{H(X)}{|X|} \rightarrow \frac{1}{\mu}.$$

Example of Application: Radial Navigation

Radial navigation is an example of application of our method. In dimension 2, the radial navigation is regenerative and θ , its regenerative time satisfies: $\mathbb{E} \exp(s\theta) < \infty$ for all $s > 0$.

Assumptions (i) and (i') hold with

$$\phi_{E(0)}(x) = \mathbf{1}(x \in B(X - \mathcal{A}(X), |X - \mathcal{A}(X)|)).$$

Indeed, on a nice point set N , $Y = \mathcal{A}(X)$ if and only if $|Y| < |X|$ and $N \cap B(0, |X|) \cap B(X, |X - Y|) = \emptyset$.

Let \mathcal{A}_{e_1} denote the directed radial navigation and $X_k = \mathcal{A}_{e_1}^k(0)$. In order to prove assumptions (ii) and (ii'), notice that:

$$\int_{\mathcal{H}(0)} \phi_{E_k}(x) dx = \int \mathbf{1}(x \in \mathcal{H}(0) \cap B(X_k - X_{k+1}, |X_k - X_{k+1}|)) dx \leq \pi_d |X_k - X_{k+1}|^d. \quad (1.52)$$

Let $D_n = \mathcal{H}(0) \cup_{l=0}^{k-1} B(X_k - X_n, |X_k - X_{k+1}|)$, N_{X_n} is a PPP of intensity $\lambda_n(x) dx = (1 - \mathbf{1}(x \in D_n)) dx$. We assume that the dimension d is 2. We define the cones $c_\alpha = \{x = (r, \theta) \in \mathbb{R}^2 : \theta \in [0, \alpha]\}$ for $\alpha > 0$, and $c_\alpha = \{x = (r, \theta) \in \mathbb{R}^2 : \theta \in (\alpha, 0]\}$ for $\alpha < 0$. The following lemma is proved in Chapter 2.

Lemma 1.4.14 *For all n ,*

$$c_{\frac{\pi}{6}} \subset D_n \quad \text{or} \quad c_{-\frac{\pi}{6}} \subset D_n.$$

This lemma implies in particular that:

$$P(|X_k - X_{k+1}| \geq t | \mathcal{F}_k) \leq e^{-\frac{\pi t^2}{12}}.$$

From Equation (1.52), we deduce, for all $s \in \mathbb{R}$:

$$\mathbb{E}(\exp(s \int_{\mathcal{H}(0)} \phi_{E_k}(x) dx) | \mathcal{F}_k) < \infty.$$

This last equation implies assumptions (ii) and (ii'). It remains to check that assumptions (iii) and (iii') hold. Let $x = (r, \theta)$, expressed in polar coordinates with basis $(0, e_1)$, $r > 0$, $\theta \in [0, \pi/2]$. The set D_k has the following property: if $x \in D_k$ then for all $0 \leq \alpha \leq \theta$, $(r, \alpha) \in D_k$ (and resp. if $\theta \in [-\pi/2, 0]$ for all $\theta \leq \alpha \leq 0$). This last property implies that $P_{e_1, k} | \mathcal{F}_k \stackrel{st}{\geq} P_{e_1, 0}$ (see Chapter 2 for details). Assumptions (iii) and (iii') follow.

1.5 Navigation Tree Topology

1.5.1 Maximal Deviation, Tree topology and f -straightness

We turn back to a navigation \mathcal{A} with a non-negative progress and we assume that an associated directed navigation \mathcal{A}_{e_1} exists for all $e_1 \in \mathbb{R}^d$. Let $X_k = \mathcal{A}^k(X)$, $P_k = |X_k| - |X_{k+1}|$, $H(X) = \inf\{k : \mathcal{A}^k(X) = 0\}$, $\mathcal{F}_k = \sigma\{X_0, \dots, X_k\}$ and let $\overline{X}_k = \langle X_k, X/|X| \rangle X/|X|$ be the projection of X_k on the straight line $\overline{0X}$. The path from X to 0 in the navigation tree \mathcal{T}_0 is denoted by $\pi(X) = \{X_0, X_1, \dots, 0\}$. $\pi(X)$ may be seen as a piecewise linear curve in \mathbb{R}^d . The maximal deviation of this curve is defined by

$$\Delta(X) = \max_{0 \leq k \leq H(X)} |X_k - \overline{X}_k|. \quad (1.53)$$

To understand the intrinsic structure of \mathcal{T}_0 we need to characterize its *ends*. An end is a semi-infinite self-avoiding path in \mathcal{T}_0 , starting from the origin: $(0 = X_0, X_1, \dots)$. The set of ends of a tree is the set of distinct semi-infinite, self-avoiding paths (two semi-infinite paths are not distinct if they share an infinite sub-path). A semi-infinite path $(0 = X_0, X_1, \dots)$ has an asymptotic direction if $X_n/|X_n|$ has a limit in the unit sphere S^{d-1} . Following Howard and Newman in [93], some properties of the semi-infinite self-avoiding paths in \mathcal{T}_0 follows from tail bounds on $\Delta(X)$.

For $X \in N$, let $\Pi_{out}(X)$ be the set of offspring of X in the \mathcal{T}_0 , namely the set $X' \in N$ such that $X \in \pi(X')$. We now state a definition introduced in [93].

Definition 1.5.1 *Let $f \in \ell^0$, a tree is said to be f -straight at the origin, if for all but finitely many vertices :*

$$\Pi_{out}(X) \subset C(X, f(|X|)),$$

where for all $X \in \mathbb{R}^d$ and $\epsilon \in \mathbb{R}^+$, $C(X, \epsilon) = \{Y \in \mathbb{R}^d : \theta(X, Y) \leq \epsilon\}$ and $\theta(X, Y)$ is the angle (in $[0, \pi]$) between X and Y .

The following result shows how to relate f -straightness to $\Delta(X)$.

Proposition 1.5.2 *Let \mathcal{T} be a random spanning tree on a PPP with an atom at 0. Let $\gamma \in (0, 1)$ and $\eta > 0$, if $\mathbb{P}(\Delta(X) \geq |X|^\gamma) \leq C_1|X|^{-d-\eta}$ and $\sup_{X \in \mathbb{R}^d} \mathbb{E}|X - \mathcal{A}(X)|^r < \infty$ for some $r > (d+1)/\gamma$ then \mathcal{T} is f -straight at the origin for $f(x) = |x|^{\gamma-1}$.*

Proof. We first prove that the number K of points T_n of N such that $\Delta(T_n) \geq |T_n|^\gamma$ is a.s. finite. From Slivnyak-Campbell's Formula :

$$\begin{aligned} \mathbb{E}K &= \mathbb{E} \sum_{T_n \in N} \mathbf{1}(\Delta(T_n) \geq |T_n|^\gamma) \\ &= \omega_{d-1} \int_0^\infty P(\Delta(x) \geq |x|^\gamma) x^{d-1} dx \\ &\leq \omega_{d-1} \int_0^\infty x^{d-1} \min(1, C_1 x^{-d-\eta}) dx < \infty. \end{aligned}$$

We define

$$B_{\gamma,x} = \{\exists X \in N : |X| \leq 2x \text{ and } |X - \mathcal{A}(X)| > x^\gamma\}.$$

Using the inequalities $\mathbb{P}(N(B(0, x)) \geq t) \leq \exp(-t \ln(t/(e\pi_d x^d)))$ and $\sup_{X \in \mathbb{R}^d} \mathbb{E}|X - \mathcal{A}(X)|^r \leq C_1$, we have

$$\begin{aligned} \mathbb{P}(B_{\gamma,x}) &\leq \mathbb{P}(N(B(0, 2x)) \geq e^2 \pi_d 2^d x^d) + e^2 \pi_d 2^d x^d \frac{\mathbb{E}|X - \mathcal{A}(X)|^r}{x^{r\gamma}} \\ &\leq \exp(-e^2 \pi_d 2^d x^d) + e^2 C_1 \pi_d 2^d x^{d-r\gamma} \\ &\leq C_1 x^{d-r\gamma} \end{aligned}$$

From Borel-Cantelli Lemma, it follows that there is some finite random x_0 so that for $X \in N \setminus B(0, x_0)$, $|X - \mathcal{A}(X)| \leq |X|^\gamma$. The rest of the proof uses the same argument as Lemma 2.7 of [93] (with $1 - \delta$ replaced by γ). \square

f -straight trees have a simple topology described by Proposition 2.8 of [93] and restated in Proposition 1.5.3.

Proposition 1.5.3 *Let \mathcal{T} be an f -straight spanning tree on a PPP. The following set of properties holds almost surely:*

- every semi-infinite path has an asymptotic direction,
- for every $u \in S^{d-1}$, there exists at least one semi-infinite path with asymptotic direction u ,
- the set of u 's of S^{d-1} such that there is more than one semi-infinite path with asymptotic direction u is dense in S^{d-1} .

In the following subsection we prove under some assumptions that \mathcal{T}_0 is f -straight with $f(x) = x^{1-\gamma}$.

1.5.2 Memoryless Isotropic navigation

We start with the simplest case in order to illustrate the method used to derive bounds on

$$\mathbb{P}(\Delta(X) \geq |X|^\gamma).$$

We assume in this paragraph that the navigation is memoryless with non-negative progress.

Let $e_1, e_2 \in S^{d-1}$, we define $\mathbb{U}(e_1, e_2) = \{R \in \mathbb{U} : R(e_2) = e_1\}$, where \mathbb{U} is the orthogonal group of \mathbb{R}^d .

Definition 1.5.4 A navigation \mathcal{A} is isotropic if for all e_1, e_2 in S^{d-1} , $x \geq 0$ and $R \in \mathbb{U}(e_1, e_2)$:

$$R\mathcal{A}(xe_2) \stackrel{\mathcal{L}}{=} \mathcal{A}(xe_1),$$

Note that if we consider $X \neq 0$ and e_1, e_2 in S^{d-1} with $\langle e_i, X/|X| \rangle = 0$ for $i = 1, 2$, the definition implies that $\langle \mathcal{A}(X), e_1 \rangle \stackrel{\mathcal{L}}{=} \langle \mathcal{A}(X), e_2 \rangle$. We can apply this fact to $e_1 = -e_2$ and we deduce

$$\mathbb{E}\langle \mathcal{A}(X), e_1 \rangle = 0.$$

All the navigation algorithms we have introduced are isotropic.

Theorem 1.5.5 Let $\gamma \in (1/2, 1)$, if the navigation is isotropic, memoryless, with non-negative progress and:

- $\mathcal{A}(xe_1) - xe_1$ converges weakly to $\mathcal{A}_{-e_1}(0)$ as x tends to $+\infty$.
- $\sup_{X \in \mathbb{R}^d} \mathbb{E}|X - \mathcal{A}(X)|^r < \infty$ with $r > (d+1)/\gamma$
- For $|X| \geq x_0$, $\mathbb{P}(P(X) \geq c) \geq \epsilon$ with $x_0, c, \epsilon > 0$.

Then for some $\eta > 0$, there exists C_1 such that

$$\mathbb{P}(\Delta(X) \geq |X|^\gamma) \leq C_1 |X|^{-d-\eta}.$$

and \mathcal{T}_0 is f -straight with $f(x) = |x|^{\gamma-1}$.

The second statement follows immediately from the first and Proposition 1.5.2. We will see in the proof of Theorem 1.5.5 that we may pick any η in $(0, r - (d+1)/\gamma)$, thus as an immediate corollary, we have:

Corollary 1.5.6 If the navigation is isotropic, memoryless and with non-negative progress and:

- $\mathcal{A}(xe_1) - xe_1$ converges weakly to $\mathcal{A}_{-e_1}(0)$ as x tends to $+\infty$.
- $\sup_{X \in \mathbb{R}^d} \mathbb{E}|X - \mathcal{A}(X)|^r < \infty$ for all $r > 1$.
- For $|X| \geq x_0$, $\mathbb{P}(P(X) \geq c) \geq \epsilon$ with $x_0, c, \epsilon > 0$.

Then for all $\epsilon > 0$ and $n \in \mathbb{N}$, there exists C_1 such that

$$\mathbb{P}(\Delta(X) \geq |X|^{1/2+\epsilon}) \leq C_1 |X|^{-n}.$$

and \mathcal{T}_0 is f -straight with $f(x) = |x|^{-1/2+\epsilon}$.

1.5.3 Proof of Theorem 1.5.5

Navigation in a cone

We fix $\gamma > 1/2$ and we assume first that there exists $0 < \alpha < \pi/2$ such that

$$\mathcal{A}(X) - X \in \mathcal{C}(\alpha, -X/|X|), \quad (1.54)$$

where $\mathcal{C}(\alpha, e_1) = \{Y \in \mathbb{R}^d \setminus \{0\} : \cos \alpha \leq \langle e_1, Y/|Y| \rangle\} \cup \{0\}$ (that is the cone with apex α and direction e_1).

Let $e_1, e_2 \in S^{d-1}$ with $\langle e_1, e_2 \rangle = 0$ and we assume that $X = |X|e_1$. We take interest to

$$U_k = \langle X_k, e_1 \rangle \quad \text{and} \quad V_k = \langle X_k, e_2 \rangle.$$

Let $F = \text{vect}(e_1, e_2)$, X_k^F the orthogonal projection of X_k on F , and $(\cos \theta_k, \sin \theta_k)$ the coordinates of the projection of $X_k^F/|X_k^F|$ on the basis (e_1, e_2) . Let $R_k \in \mathbb{U}$ such that $R_k X_k = |X_k|e_1$ and $e_2^k = R_k^{-1}e_2$. We define $p_k = \langle X_k^F - X_{k+1}^F, X_k/|X_k| \rangle$ and $q_k = \langle X_{k+1}^F - X_k^F, e_2^k \rangle$ (see figure 1.2). We have $p_k \geq 0$ (since the navigation has non-negative progress, $X_{k+1} \in \overline{B(0, |X_k|)}$) and

$$\begin{aligned} V_{k+1} &= V_k + q_k \cos \theta_k - p_k \sin \theta_k \\ U_{k+1} &= U_k - p_k \cos \theta_k - q_k \sin \theta_k \\ \tan \theta_k &= V_k/U_k. \end{aligned} \quad (1.55)$$

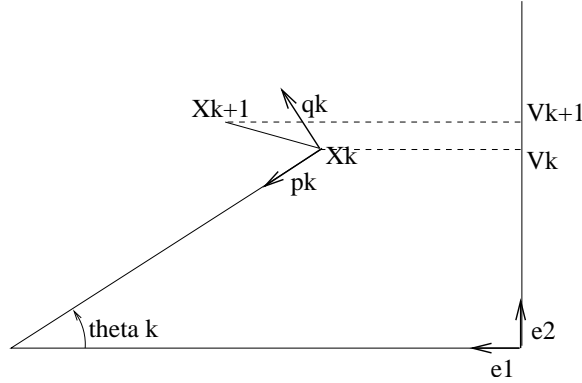

Figure 1.2: q_k, p_k, θ_k and V_k

If the navigation is isotropic and memoryless then the distribution of p_k and q_k depends only on $|X_k|$. From the isotropy we also have that $\mathbb{E}(q_k \cos \theta_k | \mathcal{F}_k) = \cos \theta_k \mathbb{E}(q_k | \mathcal{F}_k) = 0$. Let $V'_k = V_{k \wedge K}$ with

$$K = \inf\{k : V_k < 0 \text{ or } |U_k| \leq x^\gamma \tan \alpha\},$$

K is a $\{\mathcal{F}_k\}_{k \in \mathbb{N}}$ -stopping time. Since $\theta_k \in (0, \pi)$ for $k < K$ we have:

$$\mathbb{E}(V'_{k+1} | \mathcal{F}_k) = V'_k - \sin \theta_k \mathbb{E}(p_k | \mathcal{F}_k) \leq V'_k,$$

and for $k \geq K$, $\mathbb{E}(V'_{k+1} | \mathcal{F}_k) = V'_k = V_k$. Therefore $(V'_k)_{k \in \mathbb{N}}$ is a supermartingale (for the filtration $\{\mathcal{F}_k\}_{k \in \mathbb{N}}$). Let $S_0 = 0$, $S_n = \sum_{k=0}^{n-1} q_k$ and $M_n = \max_{0 \leq k \leq n} S_k$. $(S_k)_{k \in \mathbb{N}}$ is a martingale with mean 0.

Lemma 1.5.7 *If $k \leq K$ and $M_k \leq x^\gamma$,*

$$V_k \leq S_k.$$

Proof. We prove this result by iteration, by symmetry we can suppose that $0 \leq \theta_k < \pi/2$. Since $X - \mathcal{A}(X) \in \mathcal{C}(\alpha, X/|X|)$, $|q_k| \leq p_k \tan \alpha$. Notice also that if $M_k \leq x^\gamma$ and $k \leq K$ then $\tan \theta_k = V_k/U_k \leq x^\gamma/(\tan \alpha x^\gamma) \leq 1/\tan \alpha$. By Equation (1.55), it is sufficient to prove that for $\tan \theta \in [0, 1/\tan \alpha)$ and $|q| \leq p \tan \alpha$

$$q \cos \theta - p \sin \theta \leq q$$

If $q \geq 0$, there is nothing to prove. If $q \leq 0$ then we have to check that $|q| \leq p \sin \theta / (1 - \cos \theta)$. However since $|q| \leq p \tan \alpha \leq p / \tan \theta \leq p \sin \theta / (1 - \cos \theta)$ since $1/\tan \theta = \cos \theta / \sin \theta \leq \sin \theta / (1 - \cos \theta)$. \square

Lemma 1.5.8 *Let $r' < r$, for all $t > 0$, there exists $C_t > 0$ such that*

$$\mathbb{P}(M_n \geq n^\gamma t) \leq C_t n^{1-\gamma r'}.$$

Proof. This lemma is a consequence of Theorem 3.1 Equation (3.3) of Gut [84] (see also Theorem 2 in Baum and Katz [27]). This theorem is stated for a sum of independent variables but it applies to our case also. Indeed, we have the following two key features:

1. $(|q_k|)_{k \in \mathbb{N}}$ is stochastically bounded by an iid sequence $(Z_k)_{k \in \mathbb{N}}$ with $\mathbb{P}(Z_k \geq t | \mathcal{F}_k) \leq C_1 t^{-r}$, thus $\mathbb{E} Z^{r'} < \infty$.
2. $(q_k)_{k \in \mathbb{N}}$ are nearly independent: if $n, m, k \neq l \in \mathbb{N}$, $\mathbb{E} q_k^{2n+1} q_l^m = 0$ and $\mathbb{E} |q_k^{2n} q_l^{2m}| \leq \mathbb{E} Z^{2n} \mathbb{E} Z^{2m}$.

Since the proofs of Gut, Baum and Katz rely only Markov inequality and truncation, their results apply to our case. \square

Lemma 1.5.9 *For a memoryless navigation, if for $|X| \geq x_0$, $\mathbb{P}(P(X) \geq c) \geq \epsilon > 0$ then for all $\mu < c\epsilon$, there exist constants C_1 and C_0 such that:*

$$\mathbb{P}(H(X) \geq |X|/\mu) \leq C_1 \exp(-C_0 |X|).$$

Proof. Let $\tau(X) = \inf\{k : |X_k| \leq x_0\}$ and $(B_k), k \in \mathbb{N}$ be an iid sequence of Bernoulli variables with $\mathbb{P}(B_1 = 0) = 1 - \epsilon$ and $\mathbb{P}(B_1 = 1) = \epsilon$. We write $1/\mu = 1/\mu' + \eta$, for $\eta > 0$ and $\mu' < c\epsilon$, we have:

$$\begin{aligned} \mathbb{P}(H(X) \geq |X|/\mu) &\leq \mathbb{P}(N(B(0, x_0) \geq \eta |X|) + \mathbb{P}(\tau(X) \geq |X|/\mu') \\ &\leq \mathbb{P}(N(B(0, x_0) \geq \eta |X|) + \mathbb{P}\left(\sum_{k=0}^{\lfloor |X|/\mu' \rfloor - 1} B_k < |X| - x_0\right) \\ &\leq \mathbb{P}(N(B(0, x_0) \geq \eta |X|) + \mathbb{P}\left(\sum_{k=0}^{\lfloor |X|/\mu' \rfloor - 1} B_k < |X|/c\right) \\ &\leq C_1 \exp(-C_0 |X|) \end{aligned}$$

where we have the inequality $\mathbb{P}(N(B(0, x_0)) \geq t) \leq \exp(-t \ln(t/(e\pi_d x_0^d)))$ and Hoeffding's inequality: for $t < n\epsilon$, $\mathbb{P}(\sum_{k=0}^{n-1} B_k < t) \leq 2 \exp((t - n\epsilon)^2/(2n))$. \square

We are now in position to conclude the proof of Theorem 1.5.5 when Equation (1.54) holds.

For $l < n$, let $S_{l,n} = \sum_{k=l}^{n-1} q_k$, $S_{l,l} = 0$, $M_n = \max_{0 \leq k \leq n} S_k$ and $m_n = \max_{0 \leq k \leq n} -S_k = |\min_{0 \leq k \leq n} S_k|$. Finally, we define

$$K' = \inf\{k : |U_k| \leq x^\gamma \tan \alpha\}$$

A slight variation of Lemma 1.5.7 gives if $k \leq K'$, $m_n \leq x^\gamma$ and $M_n \leq x^\gamma$: $V_k \leq \max_{0 \leq l \leq k} S_{l,k} \leq S_k + m_k$. Hence

$$\mathbb{P}(\max_{0 \leq k < K'} V_k \geq x^\gamma, K' \leq n) \leq \mathbb{P}(M_n \geq x^\gamma/2) + \mathbb{P}(m_n \geq x^\gamma/2). \quad (1.56)$$

Note also that changing (q_k) into $(-q_k)$ in Lemma 1.5.8 gives $\mathbb{P}(m_n \geq n^\gamma t) \leq C_t n^{1-\gamma r'}$. From the isotropy of the navigation, we get:

$$\begin{aligned} \mathbb{P}(\Delta(X) \geq \frac{x^\gamma}{\sqrt{d} \cos \alpha}) &\leq 2d \mathbb{P}(\sup_{k \geq 0} V_k \geq \frac{x^\gamma}{\cos \alpha}) \\ &\leq 2d \mathbb{P}(\max_{0 \leq k < K'} V_k \geq x^\gamma) \end{aligned} \quad (1.57)$$

$$\begin{aligned} &\leq 2d \mathbb{P}(\max_{0 \leq k < K'} V_k \geq x^\gamma, K' \leq x/\mu) + 2d \mathbb{P}(H(X) \geq x/\mu) \\ &\leq C_1 x^{1-\gamma r'} + C_1 \exp(-C_0 x) \end{aligned} \quad (1.58)$$

Equation (1.57) stems from the following fact: if $|U_k| \leq x^\gamma \tan \alpha$ and $|V_k| \leq x^\gamma$ then (since $\mathcal{A}(X) \in B(0, |X|)$) $V_{k+1} \leq \sqrt{U_k^2 + V_k^2} \leq x^\gamma / \cos \alpha$. In Equation (1.58) we have used Equation (1.56), Lemma 1.5.8 and Lemma 1.5.9. If r' is close enough to r we have $\gamma r' - 1 > d$ and this concludes the proof of Theorem 1.5.5 when Equation (1.54) holds.

General Case

The general case is a consequence of the previous case. Indeed there exists α_x such that with $|X| = x > 0$:

$$\mathbb{P}(\mathcal{A}(X) - X \in \mathcal{C}(\alpha_x, -X/x)) \geq \frac{1}{2}, \quad (1.59)$$

where $\mathcal{C}(\alpha, e_1)$ was defined after Equation (1.54). We assume that α_x is the minimum angle such that Equation (1.59) holds.

Lemma 1.5.10

$$\alpha = \sup_{x > 0} \alpha_x < \frac{\pi}{2}.$$

Proof. Let $X = -x e_1$, $x > 0$ and \mathcal{A}_{e_1} the associated directed navigation of \mathcal{A} , $\mathcal{A}(X) - X$ converges weakly to $\mathcal{A}_{e_1}(0)$. The directed navigation has non-negative progress and there exists $\beta \in [0, \pi/2)$ such that $\mathbb{P}(\mathcal{A}_{e_1}(0) \in \mathcal{C}(\beta, e_1)) \geq 3/4$. Hence for $x \geq x_1$ large enough: $\alpha_x \leq \beta < \pi/2$.

For $x \leq x_0$, $\mathbb{P}(N^0(B(0, x)) > 1) \leq 1/2$ hence $\alpha_x = 0$.

It remains to treat the case $x_0 < x < x_1$. Let $L(x, \beta) = B(0, x) \cap \{X + \mathcal{C}^c(\beta, e_1)\}$, it appears easily that $|L(x, \beta)| \leq |L(x_1, \beta)| \leq C_1 \beta x_1^d$ and

$$\begin{aligned} \mathbb{P}(\mathcal{A}(X) - X \notin \mathcal{C}(\beta, e_1)) &\leq \mathbb{P}(N(L(x, \beta) \cap B(0, t)) > 0) \\ &\leq C_1 \beta x_1^d. \end{aligned}$$

Therefore for β large enough $\mathbb{P}(\mathcal{A}(X) - X \in \mathcal{C}(\beta, e_1)) \geq \frac{1}{2}$ and this concludes the proof. \square

Now we define $\theta = \inf\{k \geq 1 : X_k - X_{k-1} \in \mathcal{C}(\alpha, e_1)\}$ where α was defined in Lemma 1.5.10. From Lemma 1.5.10, θ is dominated by a geometric variable with parameter $1/2$. We then consider:

$$\tilde{\mathcal{A}}(X) = \mathcal{A}^\theta(X).$$

\tilde{A} is an isotropic navigation with non-negative progress moreover it satisfies Equation (1.54) holds. We will denote by $\tilde{\cdot}$ a variable defined in the previous paragraph for \tilde{A} . For example

$$\tilde{K} = \inf\{k : \tilde{V}_k < 0 \text{ or } |\tilde{U}_k| \leq x^\gamma \tan \alpha\}.$$

Let $r' < r'' < r$ A rough bound and a use of Markov inequality gives:

$$\begin{aligned} \mathbb{P}(|\tilde{A}(X) - X| \geq t) &\leq \mathbb{P}(\theta > n) + \mathbb{P}\left(\sum_{k=0}^{n-1} |X_{k+1} - X_k| \geq t\right) \\ &\leq 2^{-n} + \sum_{k=0}^{n-1} \mathbb{P}(|X_{k+1} - X_k| \geq t/n) \\ &\leq 2^{-n} + C_1 n^{r+1} t^{-r} \\ &\leq C_1 t^{-r''}, \end{aligned}$$

by picking $n = \lfloor c \ln t / \ln 2 \rfloor$. We deduce that for all $r' < r$:

$$\sup_{X \in \mathbb{R}^d} \mathbb{E}|\tilde{A}(X) - X|^{r'} < \infty.$$

We can thus apply Theorem 1.5.5 to \tilde{A} and we get:

$$\mathbb{P}(\tilde{\Delta}(X) \geq |X|^\gamma) \leq C_1 |X|^{-d-\eta},$$

this last inequality does not lead directly to the desired result. We circumvent this difficulty by introducing a new variable:

$$\bar{V}_k = \max_{\theta_k \leq l < \theta_{k+1}} V_l - V_{\theta_k} = \max_{\theta_k \leq l < \theta_{k+1}} V_l - \tilde{V}_k,$$

where $\theta_0 = 0$, $\theta_1 = 1$ and $\theta_{k+1} = \inf\{l > \theta_k : X_l - X_{l-1} \in \mathcal{C}(\alpha, e_1)\}$. We have:

Lemma 1.5.11 *Let $r'' < r'$, for all $t > 0$ there exists a constant C_t such that:*

$$\mathbb{P}\left(\max_{0 \leq k < n} \bar{V}_k \geq tn^\gamma\right) \leq C_t n^{1-\gamma r''}$$

Proof. The proof uses always the same type of rough stochastic bounds. Using Hölder inequality, we have:

$$\begin{aligned} \mathbb{E}|\bar{V}_k|^{r''} &\leq \sum_{n=1}^{\infty} \mathbb{E} \mathbf{1}(\theta_k \geq n) |V_{\theta_k+n} - V_{\theta_k+n-1}|^{r''} \\ &\leq \sum_{n=1}^{\infty} (\mathbb{P}(\theta_k \geq n))^{1-r''/r'} (\mathbb{E}|V_{\theta_k+n} - V_{\theta_k+n-1}|^{r'})^{r''/r'} \\ &\leq \sum_{n=1}^{\infty} 2^{-(n-1)(1-r''/r')} (\mathbb{E}|X_{\theta_k+n} - X_{\theta_k+n-1}|^{r'})^{r''/r'} \\ &\leq C_1, \end{aligned}$$

indeed, for $n \geq 1$, $|X_{\theta_k+n} - X_{\theta_k+n-1}|^{r'}$ is given X_{θ_k+n-1} independent of θ_k . We thus have uniformly in X : $\mathbb{P}(\bar{V}_k \geq t | \mathcal{F}_k) \leq \mathbb{P}(Z_k \geq t)$ with $(Z_k)_{k \in \mathbb{N}}$ is an iid sequence and

$$\mathbb{P}(Z_k \geq t | \mathcal{F}_k) = 1 \wedge C_1 t^{-r''}.$$

The final step follows from elementary inequalities:

$$\begin{aligned}
\mathbb{P}(\max_{0 \leq k < n} \bar{V}_k \geq tn^\gamma) &\leq \mathbb{P}(\max_{0 \leq k < n} Z_k \geq tn^\gamma) \\
&\leq 1 - \prod_{k=0}^{n-1} \mathbb{P}(Z_k \geq tn^\gamma) \\
&\leq 1 - (1 - C_1 t^{-r''} n^{-\gamma r''})^n \\
&\leq 1 - \exp(-C_1 t^{-r''} n^{1-\gamma r''}) \\
&\leq C_1 t^{-r''} n^{1-\gamma r''}.
\end{aligned}$$

for n large enough. We then relax the assumption on n by increasing C_1 . □

The end of the proof is as in the previous paragraph:

$$\begin{aligned}
\mathbb{P}(\Delta(X) \geq 2x^\gamma) &\leq \mathbb{P}(\tilde{\Delta}(X) \geq x^\gamma) + \mathbb{P}(\max_{0 \leq k < x/\mu} \bar{V}_k \geq x^\gamma) + \mathbb{P}(\tilde{H}(X) \geq x/\mu) \\
&\leq C_1 x^{1-\gamma r''}
\end{aligned}$$

1.5.4 Isotropic Regenerative Navigation

With Theorem 1.5.5, we have treated so far the case of memoryless navigation. For isotropic regenerative navigation a similar result holds. Let \mathcal{A} be a regenerative navigation with regenerative time θ : \mathcal{A}^θ is a memoryless navigation. We define:

$$L^\theta(X) = \max_{0 \leq k < \theta} |X_k - X|.$$

We have the following corollary of Theorem 1.5.5.

Corollary 1.5.12 *Let $\gamma \in (1/2, 1)$, if the navigation is isotropic, regenerative, with non-negative progress and*

- $\sup_{X \in \mathbb{R}^d} \mathbb{E} L^\theta(X)^r < \infty$ with $r > (d+1)/\gamma$
- For $|X| \geq x_0$, $\mathbb{P}(P(X) \geq c) \geq \epsilon$ with $x_0, c, \epsilon > 0$.

Then for some $\eta > 0$, there exists C_1 such that

$$\mathbb{P}(\Delta(X) \geq |X|^\gamma) \leq C_1 |X|^{-d-\eta}.$$

and \mathcal{T}_0 is f -straight with $f(x) = |x|^{1-\gamma}$.

Proof. The proof as already being done in §1.5.3. Indeed, let e_1, e_2 in S^{d-1} with $\langle e_1, e_2 \rangle = 0$ and $X = x e_1$, $x > 0$. We define $V_k = \langle X_k, e_2 \rangle$ and $\tilde{\mathcal{A}}(X) = \mathcal{A}^\theta(X)$. We may apply Theorem 1.5.5 to $\tilde{\mathcal{A}}$ and as in §1.5.3, let $\bar{V}_k = \max_{\theta_k \leq l < \theta_{k+1}} V_l - V_{\theta_k} \leq L^\theta(X_{\theta_k})$. Lemma 1.5.11 holds and we conclude similarly. □

The next corollary is a consequence of Corollary 1.5.6.

Corollary 1.5.13 *If the navigation is isotropic, regenerative, with non-negative progress and*

- $\sup_{X \in \mathbb{R}^d} \mathbb{E} L^\theta(X)^r < \infty$ for all $r \geq 1$.
- For $|X| \geq x_0$, $\mathbb{P}(P(X) \geq c) \geq \epsilon$ with $x_0, c, \epsilon > 0$.

Then for all $\epsilon > 0$ and $n \in \mathbb{N}$, there exists C_1 such that

$$\mathbb{P}(\Delta(X) \geq |X|^{1/2+\epsilon}) \leq C_1 |X|^{-n},$$

and \mathcal{T}_0 is f -straight with $f(x) = |x|^{-1/2+\epsilon}$.

A simple way to bound $L^\theta(X)$ is to note that for $r \in \mathbb{N}$:

$$L^\theta(X)^r \leq \left(\sum_{k=1}^{\theta} |X_k - X_{k-1}| \right)^r \leq \theta^{r-1} \sum_{k=1}^{\theta} |X_k - X_{k-1}|^r.$$

As an application, for the navigation on the small world graph with connection function $f(r) \sim cr^{-\beta}$, using a couple of times Holder inequality, we obtain:

Corollary 1.5.14 *For $\beta > d$, there exists $C \geq 1$ such that if $\gamma > C(d+1)/(\beta-d)$, then for some $\eta > 0$, there exists C_1 such that*

$$\mathbb{P}(\Delta(X) \geq |X|^\gamma) \leq C_1 |X|^{-d-\eta}.$$

and \mathcal{T}_0 is f -straight with $f(x) = |x|^{\gamma-1}$.

Note that a bound for the constant C could be explicitly computed. We only point out that for a Small World navigation on a PWIT, $C = 1$.

Proof. For $\beta > d$, the small world navigation is isotropic regenerative with non-negative progress. Moreover we have $\mathbb{P}(|X - \mathcal{A}(X)| \geq t) \leq C_1 ct^{d-\beta}$, similarly the tail of θ is bounded by a constant times $t^{2+d-\beta}$. We then use Equation (1.5.4) and Holder inequality. \square

1.6 Shape of the Navigation Tree

1.6.1 Shape of Memoryless Navigation

Another interesting feature is the set of points at tree-distance less than k from the origin $\mathcal{T}_0(k) = \{X \in N : \mathcal{A}^k(X) = 0\}$. The set of assumptions under consideration is:

$$(A1.6.2) \left\{ \begin{array}{l} (i) \quad \mathcal{A} \text{ is a memoryless navigation with non-negative progress.} \\ (ii) \quad \sup_{X \in \mathbb{R}^d} \mathbb{E} P(X)^r < \infty \text{ for some } r > d+2 \\ (iii) \quad F_X \text{ converges weakly to } F \text{ with } \mu = \int rF(dr) > 0. \end{array} \right.$$

Theorem 1.6.1 *Under the foregoing Assumption (A1.6.2), for all $\epsilon > 0$ there exists a.s. K such that if $k \geq K$:*

$$N \cap B(0, (1-\epsilon)k\mu) \subset \mathcal{T}_0(k) \subset B(0, (1+\epsilon)k\mu). \quad (1.60)$$

Moreover a.s. and in L^1 :

$$\frac{|\mathcal{T}_0(k)|}{\pi_d k^d} \rightarrow \mu^d, \quad (1.61)$$

In other words, the navigation tree generated by a PPP inside a ball grows linearly with the number of points. The main aim of this section is to prove Theorem 1.6.1, and in particular the fact that G_k/k^2 a.s. tends to a constant when k tends to ∞ . In the literature, this constant is known as the *volume growth*. The intuition behind Theorem 1.6.1 is as follows: from Proposition 1.3.6, a point k hops away from the origin is asymptotically at Euclidean distance $D_k \sim k\mu$ from the origin. The ball of radius D_k contains $\pi_d D_k^d$ points in N asymptotically. In order to prove Theorem 1.6.1, we need an estimate of the tail of the fluctuations of $H(X)$ around its mean. The proof of the next theorem is the heart of the proof of Theorem 1.6.1.

Theorem 1.6.2 *Under the foregoing Assumption (A1.6.2), let $r' < r$, for all $\nu < \mu$, there exists a positive constant C_1 :*

$$\text{if } |X| < n\nu - 1 \text{ and } n \geq 1, \quad \mathbb{P}(H(X) > n) \leq C_1 n(n\nu - |X|)^{-r'}.$$

Similarly for $\nu > \mu$:

$$\text{if } |X| > 1 + n\nu \text{ and } n \geq 1, \quad \mathbb{P}(H(X) < n) \leq C_1 n(|X| - n\nu)^{-r'}.$$

In particular if $\nu > \mu$, consider $n = \lfloor x/(2\nu) \rfloor$, we obtain:

$$P(H(X) > \frac{x}{\nu}) \leq C_1 |X|^{1-r'}, \quad (1.62)$$

(and similarly for $\nu < \mu$).

Strengthening the assumptions of Theorem 1.6.2, we naturally obtain:

Proposition 1.6.3 *Under the foregoing Assumption (A1.6.2), with (ii) replaced by:*

$$(ii') \sup_{X \in \mathbb{R}^d} \mathbb{E} \exp(sP(X)) < \infty \text{ for some } s > 0,$$

for all $\nu < \mu$, there exists positive constants C_0, C_1 :

$$\text{if } |X| < n\nu \text{ and } n \geq 1, \quad \mathbb{P}(H(X) > n) \leq C_1 e^{-C_0(n\nu - |X|)}.$$

Similarly for $\nu > \mu$:

$$\text{if } |X| > n\nu \text{ and } n \geq 1, \quad \mathbb{P}(H(X) < n) \leq C_1 e^{-C_0(n\nu - |X|)}.$$

We first prove Theorem 1.6.1.

Proof. We define $G_k = |\mathcal{T}_0(k)| = \sum_{X \in N} \mathbf{1}(H(X) \leq k)$, G_k is the size of the ball of center 0 and radius k for the graph-distance in \mathcal{T}_0 . We start with the proof of Equation (1.61), let $\epsilon \in (0, 1)$, we write

$$\begin{aligned} |G_k - N^0(B(0, \mu k))| &\leq \sum_{X \in N} \mathbf{1}(X \notin B(0, \mu k) \cap H(X) \leq k) \\ &\quad + \sum_{X \in N} \mathbf{1}(X \in B(0, \mu k) \cap H(X) > k) \\ &\leq \sum_{X \in N} \mathbf{1}(X \notin B(0, (1+\epsilon)\mu k) \cap H(X) \leq k) \\ &\quad + N(B(0, (1+\epsilon)\mu k) \setminus B(0, (1-\epsilon)\mu k)) \\ &\quad + \sum_{X \in N} \mathbf{1}(X \in B(0, (1-\epsilon)\mu k) \cap H(X) > k) \\ &\leq I_k + J_k + L_k. \end{aligned}$$

From Slyvniak-Campbell's formula and using Equation (1.62) for $\nu = \mu(1 + \epsilon/2)$:

$$\begin{aligned} \mathbb{E}I_k &= \int_{\mathbb{R}^d \setminus B(0, (1+\epsilon)\mu k)} \mathbb{P}(H(X) \leq k) dX \\ &\leq \omega_{d-1} \int_{(1+\epsilon)\mu k}^{\infty} C_1 x^{1-r'} x^{d-1} dx \\ &\leq C_1 k^{d-r'+1}. \end{aligned}$$

From the Borel Cantelli Lemma, we obtain that almost surely $I_k = 0$ for k large enough. Similarly, let $\nu = (1 - \epsilon/2)\mu$, we get:

$$\begin{aligned} \mathbb{E}L_k &= \int_{B(0, (1-\epsilon)\mu k)} \mathbb{P}(H(X) \geq k) dX \\ &\leq \omega_{d-1} \int_0^{(1-\epsilon)\mu k} C_1 k(k\nu - x)^{-r'} x^{d-1} dx \\ &\leq \frac{\omega_{d-1} C_1 2^{r'}}{(k\epsilon\mu)^{r'-1}} \int_0^{(1-\epsilon)\mu k} x^{d-1} dx \\ &\leq C_1 \epsilon^{1-r'} k^{d-r'+1}. \end{aligned}$$

We deduce that almost surely $L_k = 0$ for k large enough.

The ergodic properties of the PPP imply that

$$\frac{J_k}{k^d} = \frac{N(B(0, (1+\epsilon)\mu k) \setminus B(0, (1-\epsilon)\mu k))}{k^d}$$

converges almost surely and in mean toward $2d\pi_d(\mu\epsilon)^{d-1}$ (notice that $N(B(0, (1+\epsilon)\mu k) \setminus B(0, (1-\epsilon)\mu k))$ is not an increasing sequence of convex sets, to prove this convergence, we need to use the independency properties of the PPP). We thus have proved that for all $\epsilon > 0$, almost surely,

$$\limsup_k \frac{|G_k - N(B(0, \mu k))|}{k^d} \leq 2d\pi_d(\mu\epsilon)^{d-1}.$$

Hence, almost surely,

$$\lim_k \frac{G_k}{k^d} = \lim_k \frac{N(B(0, \mu k))}{k^d} = \pi_d \mu^d.$$

The convergence in L^1 convergence is a consequence of Scheffe's Lemma.

Equation (1.60) holds since we have seen that a.s. for k large enough I_k and L_k are both equal to 0. I_k is the cardinal of $\mathcal{T}(k) \cap B(0, p+\epsilon)^c$ and L_k is the cardinal of $\mathcal{T}(k)^c \cap B(0, p-\epsilon)$. \square

1.6.2 Proof of Theorem 1.6.2 and Proposition 1.6.3

We now turn to the proof of Theorem 1.6.2.

As usual let $X_k = \mathcal{A}^k(X)$ and $H(X) = \inf\{k : X_k = 0\}$. For $1 \leq k \leq H(X)$, we define the progress: $P_k(X) = |X_{k-1}| - |X_k|$ and for $k \geq H(X)$, $P_k(X) = 0$. We fix $r' < r'' < r$.

Case $\nu < \mu$.

There exists $\nu' > 0$ such that $\nu' < \nu < \mu$ and $|X| < \nu'n - 1$. Since $(P(X))$ is uniformly integrable, there exists x_0 such that:

$$\text{if } |X| \geq x_0 \text{ then } \mathbb{E}P(X) \geq \nu. \quad (1.63)$$

Let $l < n$ we have:

$$\begin{aligned} \mathbb{P}(H(X) > n) &= \mathbb{P}\left(\sum_{k=0}^{n-1} P_k < |X|\right) \\ &\leq \mathbb{P}(N(B(0, x_0)) > l) + \mathbb{P}\left(\sum_{k=0}^{n-l-1} P_k < |X| - x_0\right) \\ &\leq \exp(-l \ln \frac{l}{e\pi^d x_0^d}) + \mathbb{P}\left(\sum_{k=0}^{n-l-1} P_k - \mathbb{E}(P_k|\mathcal{F}_k) < |X| - x_0 - \sum_{k=0}^{n-l-1} \mathbb{E}(P_k|\mathcal{F}_k)\right) \\ &\leq \exp(-l \ln \frac{l}{e\pi^d x_0^d}) + \mathbb{P}\left(\sum_{k=0}^{n-l-1} P_k - \mathbb{E}(P_k|X_k) < |X| - (n-l)\nu\right), \end{aligned} \quad (1.64)$$

where in Equation (1.64) we have used Equation(1.63) together with Assumption (i): $\mathbb{E}(P_k|\mathcal{F}_k) = \mathbb{E}(P_k|X_k)$ and

$$\left\{ \sum_{k=0}^{n-l-1} P_k < |X| - x_0 \right\} \subset \bigcup_{0 \leq k \leq n-l-1} \left\{ |X_k| \geq x_0 \right\} \subset \bigcup_{0 \leq k \leq n-l-1} \left\{ \mathbb{E}(P_k|X_k) \geq \nu \right\}.$$

We define $Y_k = P_k - \mathbb{E}(P_k|X_k)$, we notice by Assumption (ii):

$$\mathbb{E}Y_k = 0 \quad \text{and} \quad \mathbb{E}|Y_k|^r \leq C_1.$$

The sequence $(Y_k)_{k \in \mathbb{N}}$ is not independent however, it is nearly independent:

1. $(|Y_k|)_{k \in \mathbb{N}}$ is stochastically dominated by an iid sequence $(Z_k)_{k \in \mathbb{N}}$ with $\mathbb{E}Z_k^{r''} < \infty$.

2. If $p, q \in \mathbb{N}$ and $k \neq l$ then $\mathbb{E}Y_k^{2p+1}Y_l^q = 0$ and $\mathbb{E}Y_k^{2p}Y_l^{2q} \leq \mathbb{E}Z_k^{2p}\mathbb{E}Z_l^{2q}$.

We can thus apply Lemma 1.7.3 which is stated for iid variables but still holds since it is based only on truncation and a systematic use of Markov inequalities. We obtain if $m \geq 1$ and $\nu - |X|/m > t_0, t_0 > 0$:

$$\mathbb{P}\left(\sum_{k=0}^{m-1} P_k - \mathbb{E}(P_k|X_k) < |X| - m\nu\right) \leq C_1 m(m\nu - |X|)^{-r'},$$

Hence, using this last inequality in Equation (1.64), and considering $l = \lfloor (\nu'/\nu - 1)n \rfloor$ we get, (since $(n-l)\nu \geq n\nu' > |X|$)

$$\mathbb{P}(H(X) > n) \leq \exp(-C_0 n) + C_1 n(n\nu' - |X|)^{-r'}, \quad (1.65)$$

then since $n \geq (n\nu' - |X|)/\nu'$, we obtain our result (with ν' instead on ν).

Case $\nu > \mu$. This case is slightly simpler, there exists x_1 such that:

$$\text{if } |X| \geq x_1 \text{ then } \mathbb{E}P(X) \leq \nu. \quad (1.66)$$

Following the same computation as in the case $\nu < \mu$

$$\begin{aligned} \mathbb{P}(H(X) \leq n) &= \mathbb{P}\left(\sum_{k=0}^{n-1} P_k = |X|\right) \\ &\leq \mathbb{P}\left(\sum_{k=0}^{n-1} P_k > |X| - x_1\right) \\ &\leq \mathbb{P}\left(\sum_{k=0}^{n-1} P_k - \mathbb{E}(P_k|\mathcal{F}_k) > |X| - x_1 - \sum_{k=0}^{n-1} \mathbb{E}(P_k|\mathcal{F}_k)\right) \\ &\leq \mathbb{P}\left(\sum_{k=0}^{n-1} P_k - \mathbb{E}(P_k|X_k) > |X| - n\nu\right) \\ &\leq C_1 n(|X| - n\nu)^{-r'}, \end{aligned} \quad (1.67)$$

where we have used the same argument and Lemma 1.7.3.

Proposition 1.6.3

The proof of Proposition is identical. It suffices to use Lemma 1.7.4 instead of Lemma 1.7.3 in Equations (1.65) and (1.67).

1.6.3 Shape of Regenerative Navigation

We extend Theorems 1.6.1 and 1.6.2 to regenerative navigation. Let \mathcal{A} be a regenerative navigation and θ its associated regenerative time. We define $P^\theta(X) = |X| - |X_\theta| = |X| - |\mathcal{A}^\theta(X)|$, the assumptions are as follows

$$(A1.6.3) \quad \begin{cases} (i) & \mathcal{A} \text{ is a regenerative navigation with non-negative progress.} \\ (ii) & \sup_{X \in \mathbb{R}^d} \mathbb{E}P^\theta(X)^r < \infty \text{ and } \mathbb{E}\theta^r < \infty \text{ for some } r > d + 2 \\ (iii) & F_X \text{ converges weakly to } F \text{ with } \int rF(dr) > 0. \end{cases}$$

We denote by $\bar{\theta} = \lim_{|X| \rightarrow \infty} \mathbb{E}\theta(X)$ and $\mu = 1/\bar{\theta} \int rF(dr) > 0$. From Proposition 1.3.6 and Lemma 1.4.1, as $|X|$ tends to infinity a.s. $H(X)/|X| \rightarrow \mu$. Not surprisingly, we obtain the next two results as corollaries of Theorems 1.6.1 and 1.6.2.

Corollary 1.6.4 *Under the foregoing Assumption (A1.6.3), let $r' < r$, for all $\nu < \mu$, there exists a positive constant C_1 :*

$$\text{if } |X| < n\nu - 1 \text{ and } n \geq 1, \quad \mathbb{P}(H(X) > n) \leq C_1 n(n\nu - |X|)^{-r'}.$$

Similarly for $\nu > \mu$:

$$\text{if } |X| > 1 + n\nu \text{ and } n \geq 1, \quad \mathbb{P}(H(X) < n) \leq C_1 n(|X| - n\nu)^{-r'}.$$

Corollary 1.6.5 *Under the foregoing Assumption (A1.6.3), the conclusions of Theorem 1.6.1 hold for \mathcal{A} .*

Corollary 1.6.5 follows from Corollary 1.6.4 exactly as Theorem 1.6.2 implies Theorem 1.6.1. We now prove corollary 1.6.4.

Proof. Let (θ_k) denote the regenerative sequence, $\tilde{\mathcal{A}}(X) = \mathcal{A}^\theta(X)$ and $H^\theta(X) = \inf\{k : X_{\theta_k} = 0\} = \sup\{k : \tilde{\mathcal{A}}^k(X) = 0\}$.

We assume first that $|X| < n\nu - 1$ and $\nu < \mu$. We may find $0 < \delta < \bar{\theta}$ such that $\nu' = \nu\bar{\theta}/\delta < \mu$ and $|X| < \nu'n - 1$. We get

$$\begin{aligned} \mathbb{P}(H(X) > n) &\leq \mathbb{P}(H^\theta(X) > \frac{n}{\delta}) + \mathbb{P}(\theta_{\lfloor \frac{n}{\delta} \rfloor} < n) \\ &\leq \mathbb{P}(H^\theta(X) > \frac{n}{\delta}) + \mathbb{P}\left(\sum_{k=0}^{\lfloor \frac{n}{\delta} \rfloor - 1} \theta_{k+1} - \theta_k < n\right) \\ &\leq \mathbb{P}(H^\theta(X) > \frac{n}{\delta}) + \mathbb{P}\left(\left|\sum_{k=0}^{\lfloor \frac{n}{\delta} \rfloor - 1} (\theta_{k+1} - \theta_k - \bar{\theta})\right| > n(1 - \bar{\theta}/\delta) - 1\right) \end{aligned} \quad (1.68)$$

We may apply Theorem 1.6.2 to $\tilde{\mathcal{A}}$ and $\tilde{\nu} = \nu'\bar{\theta} < \mu\bar{\theta}$ since we have $|X| < n\nu' - 1 < (\frac{n}{\delta})(\nu'\bar{\theta}) - 1$. The first term in the latter inequality (1.68) is thus bounded by $C_1 n/\delta(n\nu'\bar{\theta}/\delta - |X|)^{-r'} = C_1 n/\delta(n\nu - |X|)^{-r'}$. We can also apply Lemma 1.7.3 to the sequence of iid variables $Y_k = \theta_{k+1} - \theta_k - \bar{\theta}$. Thus we may upper bound the second term in Equation (1.68) by $C_1(1 - \bar{\theta}/\delta - 1/n)^{-r'} n^{1-r'}$ for n large enough to guarantee $1 - \bar{\theta}/\delta - 1/n > t_0$ with $0 < t_0 < 1 - \bar{\theta}/\delta$. Finally we obtain (since $n \geq (n\nu - |X|)/\nu$) for n large enough:

$$\mathbb{P}(H(X) > n) \leq C_1 n(n\nu - |X|)^{-r'}.$$

By increasing suitably C_1 we obtain the result for all $n \geq 1$. □

Similarly, as a consequence Proposition 1.6.3, we obtain the following corollary.

Corollary 1.6.6 *Under the foregoing Assumption (A1.6.3), with (ii) replaced by:*

$$(ii') \sup_{X \in \mathbb{R}^d} \mathbb{E} \exp(sP^\theta(X)) < \infty \text{ and } \mathbb{E} \exp(s\theta) < \infty \text{ for some } s > 0,$$

for all $\nu < \mu$, there exists positive constants C_0, C_1 :

$$\text{if } |X| < n\nu \text{ and } n \geq 1, \quad \mathbb{P}(H(X) > n) \leq C_1 e^{-C_0(n\nu - |X|)}.$$

Similarly for $\nu > \mu$:

$$\text{if } |X| > n\nu \text{ and } n \geq 1, \quad \mathbb{P}(H(X) < n) \leq C_1 e^{-C_0(n\nu - |X|)}.$$

As an example, for the small world navigation, we easily get:

Corollary 1.6.7 - For $\beta > d$, there exists $C \geq 1$ such that if $\beta > (C + 1)d + 2C$, then the conclusions of Corollaries 1.6.4 and 1.6.5 hold true with μ computed in Theorem 1.4.6.

- For $\beta = d$, let $\tilde{\mu}$ be as in Theorem 1.4.9, for all $\epsilon > 0$ there exists a.s. K such that if $k \geq K$:

$$N \cap B(0, \exp((1 - \epsilon)k\tilde{\mu})) \subset \mathcal{T}_0(k) \subset B(0, \exp((1 + \epsilon)k\tilde{\mu})).$$

Moreover a.s. and in L^1 :

$$\frac{\ln |\mathcal{T}_0(k)|}{k} \rightarrow d\tilde{\mu}.$$

- For $d - 2 < \beta < d$, let $\alpha = 1 - (d - \beta)/2$, for all $\epsilon > 0$ there exists a.s. K such that if $k \geq K$:

$$N \cap B(0, \exp(\alpha^{(1-\epsilon)k})) \subset \mathcal{T}_0(k) \subset B(0, \exp(\alpha^{(1+\epsilon)k})).$$

Moreover a.s. and in L^1 :

$$\frac{\ln \ln |\mathcal{T}_0(k)|}{k} \rightarrow \ln \alpha.$$

1.7 Miscellaneous

1.7.1 Further examples of navigation

Ray Navigation

This navigation is built up artificially from the directed navigation introduced by Ferrari et al. in [64] to obtain their Poisson forest. The main interest of this navigation is that its mathematical analysis is fairly simple, indeed this navigation is memoryless for a PPP.

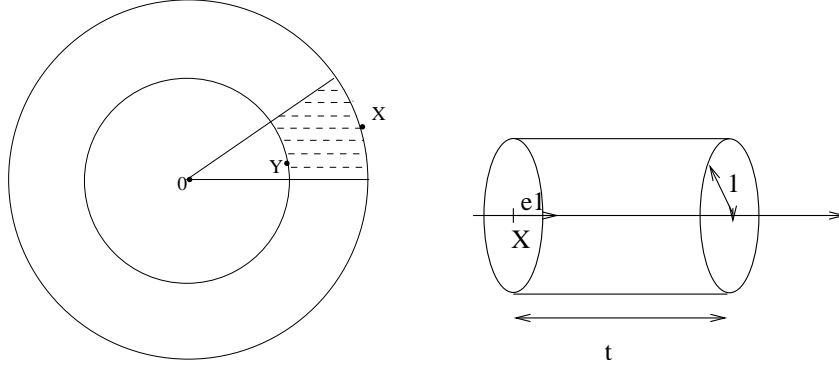

Figure 1.3: *Left:* $\mathcal{A}(X) = Y$ if the dashed region has no point (dim. 2). *Right:* $R(X, t)$ in dim. 3.

For $X \in \mathbb{R}^d \setminus \{0\}$ and $t \in \mathbb{R}_+$, let $\mathcal{C}(X) = \{Y \in \mathbb{R}^d : |Y| < |X|, 0 \leq \langle X, Y \rangle \leq |X||Y| \cos(2\pi \wedge |X|^{-1})\}$. $\mathcal{C}(X)$ is a cone intersected with $B(0, X)$ tuned to guarantee that for $|X| \geq 1$, $\overline{\mathcal{C}(X)} \cap \partial B(0, |X|)$ is a calotte on S^{d-1} with $(d - 1)$ -Lebesgue measure the volume of the unit ball in \mathbb{R}^{d-1} (i.e. $\pi^{d/2}/\Gamma(d/2 + 1)$). If $0 \in N$, the ray navigation from 0 to X is defined as (see Figure 1.3):

$$\mathcal{A}(X) = |Y| \quad \text{if } |Y| < |X| \text{ and } \mathcal{C}(X) \cap \overline{B(0, |X| - |Y|)}^c \cap N = \emptyset.$$

Let $R(X, t)$ denote the open cylinder of height $t > 0$ with direction e_1 generated by a $(d - 1)$ -dimensional ball of center X and radius 1 orthogonal to e_1 (see Figure 1.3). The directed navigation introduced by Ferrari et al. is:

$$\mathcal{A}_{e_1}(X) = |Y| \quad \text{if } \langle Y - X, e_1 \rangle > 0 \text{ and } R(X, \langle Y - X, e_1 \rangle) \cap N = \emptyset.$$

Hierarchical Navigation

In view of applications, it is interesting to consider more sophisticated navigation algorithms, for example the closest point between the ancestor given by a radial navigation and a small world navigation.

A more appealing model is as follows. We divide our locally finite point set N into point sets N_1 and N_2 . If $X \in N_1$ then a navigation \mathcal{A}_1 is performed on the point set N and if $X \in N_2$ then a navigation \mathcal{A}_2 is performed.

We consider the following example, in a network there are two types of vertices, N_1 and N_2 . Vertices in N_1 are highly connected whereas vertices in N_2 are poorly connected. The intensity of N_1 is much smaller than the intensity of N_2 . Let $G_D = (N_1 \cup N_2, E_D)$ be the Delaunay graph on $N_1 \cup N_2$ and $G_{SW} = (N_1, E_{SW})$ denote a small world graph on N_1 . In a wireless communication scenario, E_D could be a wireless link (short) and E_{SW} a wired link (long), N_2 is the set of wireless users in an ad-hoc network and N_1 the set of entry points to a wired networks. A maximal progress navigation is performed on the graph $G = (N, E_D \cup E_{SW})$. A hierarchical structure naturally appears, a navigation from $X \in N_2$ to $0 \in N_2$ will probably start by short links on G_D until it finally reaches a point in N_1 then long links on G_{SW} are followed until the path gets close of the destination. Then the path ends with a sequence of short links on G_D to its destination.

It is of course possible to combine more general navigation schemes by dividing N into k point sets.

1.7.2 Collection of technical Lemmas

Lemma 1.7.1 *Let f be a measurable non-negative function and $\lim_{x \rightarrow +\infty} f(x) = 0$. There exists a measurable positive non-decreasing function $g(x)$ with $\lim_{x \rightarrow \infty} g(x) = \infty$ such that:*

$$\lim_{x \rightarrow +\infty} \int_x^{x+g(x)} f(y) dy = 0.$$

Proof. Let $F(x) = \sup_{y \geq x} f(y)$, F satisfies the same hypothesis than f and F is non-increasing. If $F(x) = 0$ for x large enough any function g will work. Otherwise $F(x) > 0$ and the function $g(x) = 1/\sqrt{F(x)}$ trivially satisfies all the requirements. Indeed:

$$\int_x^{x+g(x)} f(y) dy \leq g(x)F(x) \leq \sqrt{F(x)}.$$

□

Lemma 1.7.2 *Let $(X_n), n \in \mathbb{N}$, be a sequence of real valued random variables adapted to a filtration $\{\mathcal{F}_n\}, n \in \mathbb{N}$. Assume that $X_{n+1} | \mathcal{F}_n \stackrel{st}{\leq} Y$, where Y is a random variable. Then for all stopping time N :*

$$\sum_{k=1}^N X_k \leq \sum_{k=1}^N Y_k,$$

where $(Y_k), k \in \mathbb{N}$, is a iid sequence with the distribution of Y .

Note that the sequence $(Y_k)_{k \in \mathbb{N}}$ is not necessarily independent of N .

Proof. For all n in \mathbb{N} , we check easily that

$$\sum_{k=1}^n X_k \leq \sum_{k=1}^n Y_k.$$

We assume first that a.s. $N \leq n$. Notice $\mathbf{1}(N \geq (k+1))$ is \mathcal{F}_k -measurable, thus $X_{k+1}\mathbf{1}(N \geq k+1) \leq Y_k\mathbf{1}(N \geq k+1)$. Since a.s. $\sum_{k=1}^N X_k = \sum_{k=1}^n \mathbf{1}(N \geq k)X_k$, we deduce:

$$\sum_{k=1}^N X_k \leq \sum_{k=1}^n Y_k.$$

For the general case, we consider $N_n = N \wedge n$ and we let n tends to infinity. \square

Lemma 1.7.3 *Let $(X_k), k \in \mathbb{N}$, be a sequence of iid real valued random variable. We assume that $\mathbb{E}X_1 = 0$ and $\mathbb{E}|X_1|^r < \infty$ for some $r > 1$. Then for all $1 < r' < r$, and $t_0 \geq 0$ there exists C_1 such that, for all $t > t_0$ and $n \geq 1$:*

$$\mathbb{P}(|\sum_{k=1}^n X_k| \geq tn) \leq C_1 t^{-r'} n^{1-r'}.$$

Proof. A proof of this lemma follows step by step the proof of Theorem 4 of Baum and Katz [27]. As it is pointed there, we can suppose that the distribution of X_1 is symmetric. Let $X_k^{[tn]} = X_k \mathbf{1}(X_k \leq tn)$, we write:

$$\begin{aligned} n^{r'-1} \mathbb{P}(|\sum_{k=1}^n X_k| \geq tn) &\leq n^{r'-1} n \mathbb{P}(|X_k| \geq tn) + n^{r'-1} \mathbb{P}(|\sum_{k=1}^n X_k^{[tn]}| \geq tn) \\ &\leq t^{-r'} \mathbb{E}|X_k|^{r'} + n^{r'-1} \mathbb{P}(|\sum_{k=1}^n X_k^{[tn]}| \geq tn), \end{aligned}$$

where we have used Markov inequality. We bound the second term exactly as in the proof of Theorem 4 of [27], let p be an even integer strictly larger than $2r' - 1$, from Markov inequality

$$n^{r'-1} \mathbb{P}(|\sum_{k=1}^n X_k^{[tn]}| \geq tn) \leq t^{-p} n^{r'-p-1} (n \mathbb{E}X_1^{[tn]p} + n(n-1) \mathbb{E}X_1^{[tn]p-2} \mathbb{E}X_1^{[tn]2} + \dots)$$

Let $\{2i_1, \dots, 2i_m\}$ be a partition of r into positive even integers, the corresponding term in the preceding expansion is bounded by $t^{-p} n^{r'+m-p-1} \mathbb{E}X_1^{[tn]^{i_1}} \dots \mathbb{E}X_1^{[tn]^{i_m}}$. Note that $\mathbb{E}X_1^{[tn]^{2i}} \leq C_1$ if $2i \leq r$ and $\mathbb{E}X_1^{[tn]^{2i}} \leq C_1 t^{2i-r'} n^{2i-r'}$ if $2i > r'$. Hence if $W = \{j : 2i_j > r'\}$ we bound the term by $C_1 t^{-p} n^{r'+m-p-1} \prod_{j \in W} t^{2i_j-r'} n^{2i_j-r'} \leq C_1 t^{-|W|r'-p+\sum_{j \in W} 2i_j} f(n)$. It is proved in Theorem 4 of [27] that $f(n) \in \ell^0$, it remains to check the exponent in t : $\alpha = -|W|r' - p + \sum_{j \in W} 2i_j$. If $W = \emptyset$ then it reduces to $\alpha = -p \leq -r'$ and if $|W| \geq 1$ since $\sum_{j \in W} 2i_j \leq 2r$ we obtain $\alpha \leq -r'$ and this concludes the proof. \square

Lemma 1.7.4 *Let $(X_k)_k$ be a sequence of real random variables and $\{\mathcal{F}_k\}_k$ a filtration of this process. If $\mathbb{E}(X_{n+1}|\mathcal{F}_n) = 0$ and $\mathbb{P}(|X_{n+1}| \geq t|\mathcal{F}_n) \leq C_1 \exp(-C_0 t)$ then for all $t_0 > 0$, there exist positive constants C_0, C_1 such that for all $t \geq t_0$:*

$$\mathbb{P}(|\frac{1}{n} \sum_{k=1}^n X_k| \geq t) \leq C_1 e^{-C_0 n t}.$$

Proof. This lemma relies on a classical computation on large deviations, we only give a sketch of the proof. Let $\Lambda_n(\lambda) = \ln \mathbb{E}(e^{\lambda X_n} | \mathcal{F}_{n-1})$ and $\Lambda_n^*(t) = \sup_{\lambda} \lambda t - \Lambda_n(\lambda)$, the Fenchel-Legendre transform of Λ_n . With have $\Lambda_n^*(0) = 0$, the condition $\mathbb{P}(|X_{n+1}| \geq t | \mathcal{F}_n) \leq C_1 \exp(-C_0 t)$ ensures that for $t \neq 0$, $\Lambda_n^*(t)$ is positive and lower bounded uniformly in n by a positive C_0 . For $t \geq 0$, Λ_n^* is non-decreasing and convex (refer to [57]), hence if $t \geq t_0 > 0$, $\Lambda_n^*(t) \geq t \frac{\Lambda_n^*(X_0)}{t_0} \geq t C_0$. As usual for upper bounds in large deviation, the rest of the proof follows from Chernoff's inequality. \square

1.7.3 A few results of Renewal Theory

Lemma 1.7.5 *Let $S_0 = 0$ and $S_n = \sum_{k=0}^{n-1} U_k$ where (U_k) is an i.i.d. sequence of positive reals with common distribution F . We assume that for some $0 < \alpha < 1$ and $c > 0$, as t goes to infinity $\bar{F}(t) \sim c/t^\alpha$. Define $\tau(x) = \inf\{n : S_n \geq x\}$, as x tends to $+\infty$ we have:*

$$\frac{\tau(x)}{x^\alpha} \Rightarrow \frac{1}{\Gamma(1-\alpha)c} \chi_\alpha^{-1/\alpha},$$

where χ_α is an α -stable random variable.

Proof. This lemma is a restatement of Equation (XI.5, 5.6) in [62]. \square

This lemma is a corollary of Rogozin's Relative Stability Theorem (Theorem 8.8.1. of [31]).

Lemma 1.7.6 *Let $S_0 = 0$ and $S_n = \sum_{k=0}^{n-1} U_k$ where (U_k) is an i.i.d. sequence with common distribution F . We assume that for some $c > 0$, as t goes to infinity $\bar{F}(t) \sim c/t$. Define $\tau(x) = \inf\{n : S_n \geq x\}$, as x tends to $+\infty$, a.s. we have:*

$$\lim_{x \rightarrow +\infty} \frac{\tau(x) \ln x}{x} = \frac{1}{c}.$$

Lemma 1.7.7 *Let $S_0 = 0$ and $S_n(u) = \sum_{k=0}^{n-1} \mathbf{1}(U_k < u) U_k$ where (U_k) is an i.i.d. sequence of positive reals with common distribution F . We assume that for some $0 < \alpha < 1$ and $c > 0$, as t goes to infinity $\bar{F}(t) \sim c/t^\alpha$. Let $\tau_\epsilon(x) = \inf\{n : S_n(x\epsilon(x)) \geq x\}$, with $\lim_{x \rightarrow \infty} \epsilon(x) = 0$ and $\lim_{x \rightarrow \infty} x\epsilon(x) = \infty$. Then as x tends to infinity, a.s.:*

$$\lim_x \frac{\mathbb{E}\tau_\epsilon(x)}{x^\alpha \epsilon(x)^{\alpha-1}} = \frac{1-\alpha}{c}.$$

Similarly, if $\bar{F}(t) \sim c/t$, a.s.:

$$\lim_x \frac{\mathbb{E}\tau_\epsilon(x) \ln(x\epsilon(x))}{x} = \frac{1}{c}.$$

Proof. Notice that $m(x) = \mathbb{E}U_n \mathbf{1}(U_n < x\epsilon(x)) \sim_x x^{1-\alpha} \epsilon(x)^{1-\alpha} c / (1-\alpha)$. We have $x \leq S_{\tau_\epsilon(x)} \leq x + U_{\tau_\epsilon(x)}$, thus from Wald equality, we have: $x \leq m(x) \mathbb{E}\tau_\epsilon(x) \leq x + \mathbb{E}U_{\tau_\epsilon(x)} \mathbf{1}(U_{\tau_\epsilon(x)} < x\epsilon(x)) \leq x(1 + \epsilon(x))$. Hence for x large enough: $x^\alpha \epsilon(x)^{\alpha-1} (1-\alpha)/c \leq \mathbb{E}\tau_\epsilon(x) \leq x^\alpha \epsilon(x)^{\alpha-1} (1 + \epsilon(x)) (1-\alpha)/c$. For $\alpha = 1$, the proof is identical. \square

Remark 1.7.8 Assume $0 < \alpha < 1$ and let $\epsilon_k(x) = |x|^{-1/k}$ so that $x\epsilon_k(x) = |x|^{(k-1)/k}$. For $k > 1$, we have $m_k(x) = \mathbb{E}U_k \mathbf{1}(U_k < |x|^{(k-1)/k}) \sim_x x^{(1-\alpha)(k-1)/k} c / (1-\alpha) = l_k(x)$ uniformly in k : $\lim_x \sup_{k > 1} m_k / l_k(x) = 1$. As in the proof of Lemma 1.7.7, for x large enough, for all k we have $\mathbb{E}\tau_{\epsilon_k}(x) \leq x^{1/k + \alpha(k-1)/k} (1 + |x|^{-1/k}) (1-\alpha)/c$. Therefore:

$$\limsup_x \sup_k \frac{\mathbb{E}\tau_{\epsilon_k}(x)}{x^{1/k + \alpha(k-1)/k}} \leq 2 \frac{1-\alpha}{c}. \quad (1.69)$$

Chapter 2

The Radial Spanning Tree of a Poisson Point Process

Résumé Nous analysons une navigation particulière, la navigation radial et son arbre de navigation associé, l'arbre couvrant radial. Cet arbre a une structure radiale simple avec l'origine prise comme racine. L'ensemble des sommets est une réalisation d'un processus ponctuel de Poisson.

Nous utilisons des idées issues de la géométrie stochastique pour étudier des fonctionnelles locales de l'arbre aléatoire, comme la distribution de la longueur d'une arête ou le degré moyen d'un sommet. Loin de l'origine, nous prouvons que ces propriétés locales sont proches de celles de l'arbre couvrant dirigé introduit par Bhatt et Roy.

Nous utilisons ensuite la théorie des chaînes de Markov à espace continu pour analyser des propriétés non locales de l'arbre, comme la forme et la structure des chemins semi-infini ou encore l'ensemble des sommets de génération inférieure à k de l'origine.

Cette classe d'arbre couvrant à des applications dans de nombreux domaines et en particulier dans les réseaux de capteurs où l'information est rassemblée vers un noeud central.

Abstract We analyze a particular navigation, the radial navigation and its associated navigation tree, the radial spanning tree. This tree has a simple radial structure with the origin as its root. The set of vertices is a realization of an homogeneous Poisson point process of the plane.

We first use stochastic geometry arguments to analyze local functionals of the random tree such as the distribution of the length of the edges or the mean degree of the nodes. Far away from the origin, these local properties are shown to be close to those of the directed spanning tree introduced by Bhatt and Roy.

We then use the theory of continuous state space Markov chains to analyze some non local properties of the tree such as the shape and structure of its semi-infinite paths or the shape of the set of its nodes less than k generations away from the origin.

This class of spanning trees has applications in many fields and in particular in wireless sensor communication networks where information has to be gathered at a central node.

2.1 Introduction

In this chapter we analyze carefully the navigation tree associated to the radial navigation, *Radial Spanning Tree* (RST). This tree holds similarities with the minimal directed spanning tree ([71], [131], [130]) and the Poisson forest (as defined in [64], [63]). The mathematical analysis of the RST is conducted on a homogeneous Poisson point process (PPP) on the plane. The scope of this chapter is two-fold: to prove some local geometric properties using stochastic geometry and to derive asymptotic properties such as the characterization of the semi-infinite paths. We will use the theory developed in Chapter 1 and present also some alternative direct proofs.

In the next section, we give the basic definition and we summarize our main results. Section 2.3 gives various distributions on local properties on the tree. In Section 2.4 we focus on the Directed Spanning Forest (DSF) which can be seen as the limit of the RST far away from the origin. In Sections 2.5.1 and 2.5.3, we prove asymptotic shape theorems on the RST. Section 2.5.2 contains a proof of a law of large numbers on a semi-infinite path of the RST and Section 2.6 the proof of a law of large numbers for the spatial averages. Finally in Section 2.7, we discuss some extensions of the RST, and in particular the case of multiple cluster heads, and give some open questions.

2.2 The Radial Spanning Tree

2.2.1 Definition

As in the previous chapter, $|\cdot|$ will denote the Euclidian norm on \mathbb{R}^d , $\langle \cdot, \cdot \rangle$ the usual scalar product, and $B(X, r)$ the open ball of radius r and center X . A set of points N of \mathbb{R}^d is said to be *non-equidistant* if there do not exist points X, Y, Z, T of N such that $\{X, Y\} \neq \{Z, T\}$ and $|X - Y| = |Z - T|$.

If N is a countable set of points in \mathbb{R}^d with no accumulation points, we write for all bounded sets A :

$$N(A) = \sum_{X \in N} \mathbf{1}(X \in A).$$

Let N be a countable set of points in \mathbb{R}^d , non-equidistant, with no accumulation points and such that $0 \in N$. The RST of N , $\mathcal{T}_0 = (N, E)$ is the navigation tree associated to the radial navigation \mathcal{A} , if $X, Y \in N^0$, $X \neq 0$:

$$\mathcal{A}(X) = |Y| \quad \text{if} \quad N(B(X, |X - Y|) \cap B(0, |X|)) = \emptyset,$$

(with the convention that $\mathcal{A}(0) = 0$). The non-equidistant property is needed to ensure that there is no tie: a vertex X which is not the origin has exactly one nearest neighbor which is closer to the origin. In this chapter we will consider only point sets in the plane \mathbb{R}^2 . All the results should extend to higher dimension. We consider an orthonormal basis $(0, e_x, e_y)$. Consider now some homogeneous Poisson point process N on the plane, with intensity $\lambda > 0$ and $N^0 = N + \delta_0$ its Palm version. Since the Poisson point process is a.s. non equidistant, we can a.s. generate the RST \mathcal{T}_0 of N^0 . Since, \mathcal{T}_0 is scale-invariant, without loss of generality, we can set $\lambda = 1$, for a general λ , all results follow by multiplying distances by $\sqrt{\lambda}$. From the invariance of the PPP by rotation, we deduce also that the law of the RST is invariant by rotation. An instance of such RST is given in Figure 2.1.

We now define another random graph which is closely related to the RST. Let $(0, e_1, e_2)$ be an orthonormal basis of \mathbb{R}^2 . On a locally finite non-equidistant point set N , we define, \mathcal{T}_{e_1} the

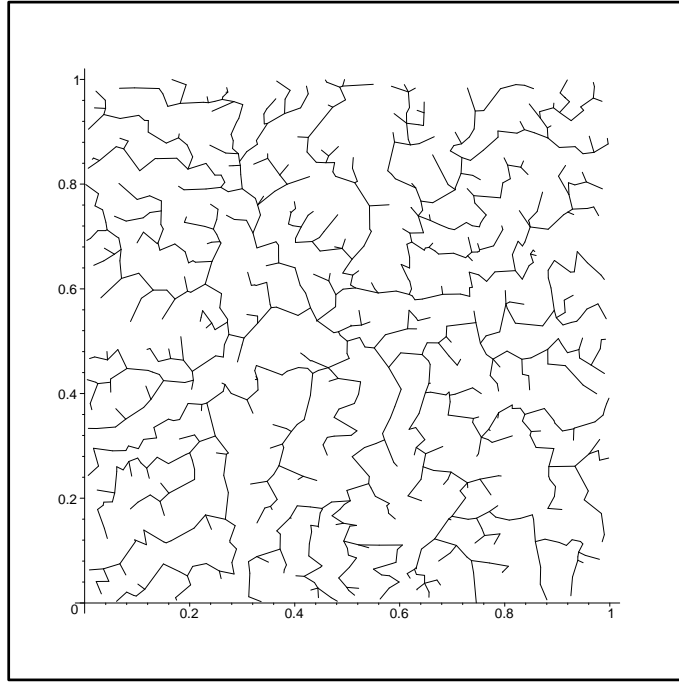

Figure 2.1: Radial spanning tree of 1000 points uniformly and independently distributed in the unit square.

Directed Spanning Forest (DSF) with direction e_1 as the directed navigation forest associated to the directed navigation, if $X, Y \in N$:

$$\mathcal{A}_{e_1}(X) = Y \quad \text{if} \quad N(B(X, |X - Y|) \cap \mathcal{H}_{e_1}(X)) = \emptyset,$$

where $\mathcal{H}_{e_1}(X) = \{Y \in \mathbb{R}^d : \langle e_1, Y - X \rangle > 0\}$. The ancestor of $X \in N$ is the nearest point of N which has a strictly larger e_1 -coordinate. This random graph was first introduced by Bhatt and Roy in [28] and it also holds some similarities with the Poisson forest.

2.2.2 Notation

The cardinality of set S will also be denoted by $|S|$. We will denote the generation of $X \in N^0$ as:

$$H(X) = \inf\{k \geq 0 : \mathcal{A}^k(X) = 0\},$$

$\pi_0(X)$ is the path from X to the origin, defined as the sequence of ancestors of X : $\pi_0(X) = \{X, \mathcal{A}(X), \dots, \mathcal{A}^{H(X)}(X) = 0\}$. In Section 2.5.1, $\pi_0(X)$ will also be thought of as a piecewise linear curve in \mathbb{R}^2 , namely as the union of the edges of this sequence.

Throughout the chapter, we will focus on functionals F defined on the vertices of \mathcal{T}_0 , such as the length of the edge $(X, \mathcal{A}(X))$, its orientation etc. For any $X \in \mathbb{R}^2$, $F(X)$ is defined on the tree \mathcal{T}_0 constructed over $N^{0,X} = N^0 + \delta_X$. This definition is consistent with Slywniak's theorem: if \mathbb{P} is the probability measure of the Poisson point process N , the Palm measure of N with two points 0 and X is $\mathbb{P} * \delta_X * \delta_0$. Hence if $X \neq 0$, a.s. $N^{0,X}$ is non-equidistant and $F(X)$ can be interpreted as the value of the functional F conditioned on the fact that X is a vertex of the tree.

From the isotropy of the PPP, the law of $F(X)$ will often depend on X only through its radius $|X|$. Consequently we will often write $F(|X|)$ instead of $F(X)$.

Several qualitative results of the present chapter involve constants. For the sake of clarity, we will use C_0 to denote a positive constant to be thought of as small and C_1 to denote a positive constant to be thought of as large. The exact value of C_0 and C_1 may change from one line to the other and we could for example write: $C_0/C_1 = C_0$. The important point is that C_0 and C_1 are universal constants that will never depend on the parameters of the problem.

2.2.3 Summary of Results

Topology of the Radial Spanning Tree

We have seen that if N^0 is a Poisson point process under its Palm version, \mathcal{T}_0 is a.s. a tree. We will check also that this tree is a.s. locally finite (i.e. no vertex has an infinite degree).

The next step to understand the intrinsic structure of \mathcal{T}_0 is to characterize its *ends*. An end is a semi-infinite self-avoiding path in \mathcal{T}_0 , starting from the origin: $(0 = X_0, X_1, \dots)$. The set of ends of a tree is the set of distinct semi-infinite, self-avoiding paths (two semi-infinite paths are non distinct if they share an infinite sub-path).

A semi-infinite path $(0 = X_0, X_1, \dots)$ has an asymptotic direction if $X_n/|X_n|$ has an a.s. limit in the unit sphere S^1 .

The following theorem will be a consequence of Proposition 2.8 in Howard and Newman [93] and the work of chapter 1. It characterizes the ends of the RST:

Theorem 2.2.1 *For all $\epsilon > 0$, \mathcal{T}_0 is f -straight at 0 with $f(r) = r^{-1/2+\epsilon}$. In particular, the following set of properties holds almost surely:*

- every semi-infinite path has an asymptotic direction,
- for every $u \in S^1$, there exists at least one semi-infinite path with asymptotic direction u ,
- the set of u 's of S^1 such that there is more than one semi-infinite path with asymptotic direction u is dense in S^1 .

This theorem shows that the RST strongly differs from the minimal spanning tree. In dimension two, it has been proved that the minimal spanning tree has only one end (see Alexander [7]).

Another property of the tree of interest to us is the set of points at tree-distance less than k from the origin $\mathcal{T}_0(k) = \{X \in N : \mathcal{A}^k(X) = 0\}$.

Theorem 2.2.2 *There exists a constant $p > 0$ such that for all $\epsilon > 0$, there exists a.s. K such that for $k \geq K$ large enough:*

$$N \cap B(0, (1 - \epsilon)kp) \subset \mathcal{T}_0(k) \subset B(0, (1 + \epsilon)kp). \quad (2.1)$$

Moreover a.s. and in L^1 :

$$\frac{|\mathcal{T}_0(k)|}{k^2} \rightarrow \pi p^2, \quad (2.2)$$

In other words, the graph-diameter of the RST generated by a Poisson Point Process inside a ball grows linearly with the number of points.

Geometry of the Radial Spanning Tree

We will focus on two types of geometrical results. The first type concerns functionals $F(X, \mathcal{T}_0)$ which depend only on vertices around X . For example, we will give explicit formulae for the distributions of $L(X) = |X - \mathcal{A}(X)|$ (the length of the edge with the ancestor), $P(X) = |X| - |\mathcal{A}(X)|$ (the progress to the origin) and the expectations of the degree $D(X)$ of node X in the tree.

More generally, we will prove a limit theorem for *stable functionals*, see Definition 1.2.1. We will prove the following theorem where \mathcal{T}_{-e_x} denotes the DSF with direction $-e_x$.

Theorem 2.2.3 *Let F be a stabilizing functional for \mathcal{T}_{-e_x} . As x tends to infinity, the distribution of $F(xe_x, \mathcal{T}_0)$ converges in total variation toward the distribution of $F(0, \mathcal{T}_{-e_x})$.*

This type of result has already been proved for the maximal progress navigation, see Theorem 1.2.3. As it is pointed by Corollary 1.2.5, it can be easily related to the local weak convergence of geometric graphs as it is defined for the Objective Method (refer to Aldous and Steele [5]).

The second class of geometrical results is of different nature: it concerns the path $\pi_0(X)$ from X to the origin. The simplest result bears on $H(X)$, the generation of X in the RST, that is the cardinal of $\pi_0(X)$. Let $X_k = \mathcal{A}^k(X)$ be the sequence of points in $\pi_0(X)$. Along the line of Howard and Newman [93], it is interesting to look at $\sum_{k=0}^{H(X)-1} |X_{k+1} - X_k|^\alpha$, with $\alpha > 0$. More generally, we will prove:

Theorem 2.2.4 *Let p be the constant defined in Theorem 2.2.2. There exists a probability measure $\pi(\cdot)$ on \mathbb{R} such that if $g(X)$ is a measurable function from \mathbb{R}^2 to \mathbb{R} , $|g(X)| \leq C_1(1 + |X|^\alpha)$ for some $\alpha > 0$, then a.s.:*

$$\lim_{|X| \rightarrow +\infty} \frac{H(X)}{|X|} = \frac{1}{p} \quad \text{and} \quad \lim_{|X| \rightarrow +\infty} \frac{1}{H(X)} \sum_{k=1}^{H(X)} g([X_{k-1} - X_k]_{X_{k-1}}) = \pi(g),$$

where $[u]_v$ is the vector u rotated by an angle $-\theta$ and $v = r \cos \theta \cdot e_x + r \sin \theta \cdot e_y$ ($[u]_v$ is the vector u expressed in the local coordinates of v). We also have a.s.:

$$\lim_{x \rightarrow +\infty} \frac{1}{H(xe_x)} \sum_{k=1}^{H(xe_x)} g(X_{k-1} - X_k) = \pi(g) \quad (2.3)$$

We prove in Section 2.4 that the probability measure π can be interpreted as the stationary measure on the infinite edge process in the DSF. Theorem 2.2.4 is a law of large numbers and π can be understood as the limit probability measure of an edge conditioned on being on a semi-infinite path.

Theorems 2.2.3 and 2.2.4 are of different nature. In particular the mean of $L(X)$ is different from the average of the lengths of the edges along the path $\pi_0(X)$. The paradox vanishes if we understand that being on a long path is a bias. We will discuss this point in Section 2.6.

2.3 Local Properties of the Radial Spanning Tree

2.3.1 Distribution of the Length of Edges

Let $X \in \mathbb{R}^2$ and $L(X) = |X - \mathcal{A}(X)|$. Let $0 \leq r < |X|$, we get:

$$\begin{aligned} \mathbb{P}(L(X) \geq r) &= \mathbf{1}(r \leq |X|) \mathbb{P}(N(B(X, r) \cap B(0, |X|) = 0)) \\ &= \mathbf{1}(r \leq |X|) e^{-M(|X|, r)}, \end{aligned} \quad (2.4)$$

where $M(x, r)$ is the volume of the lune of the right part of Figure 2.2. Using the formula for the surface depicted by the left figure of Figure 2.2, we get that:

$$M(x, r) = x^2\left(\phi - \frac{\sin(2\phi)}{2}\right) + r^2\left(\frac{\pi}{2} - \frac{\phi}{2} - \frac{\sin(\phi)}{2}\right), \quad (2.5)$$

with

$$\phi = 2 \arcsin \frac{r}{2x}.$$

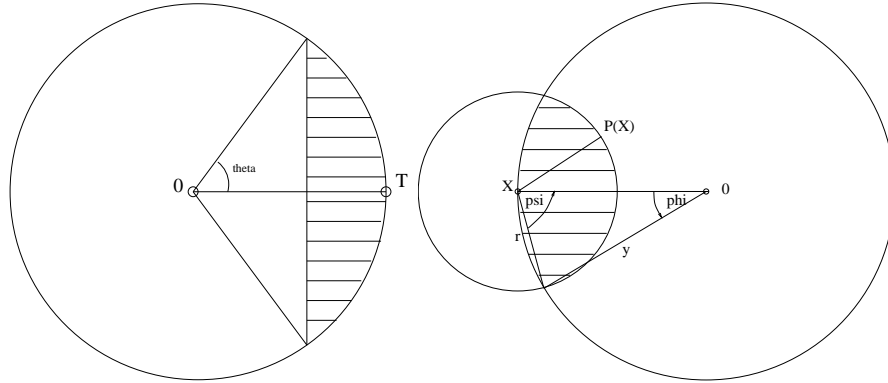

Figure 2.2: Left: the surface of the dashed lens is equal to $\frac{|T|^2}{2}|2\theta - \sin 2\theta|$. Right: the dashed lune.

With an abuse of notation, for $x > 0$, we define: $L(x) = L(xe_x)$. $L(x)$ has a density on $(0, x)$ equal to

$$\frac{d}{dr}M(x, r)e^{-M(x, r)}$$

and a mass at x equal to

$$e^{-M(x, x)} = e^{-x^2(2\pi/3 - \sin(2\pi/3))} = e^{-x^2(2\pi/3 - \sqrt{3}/2)}. \quad (2.6)$$

Notice that the distribution function of $L(x)$ is not stochastically monotone in x . Its mean $\mathbb{E}L(x)$ which is plotted in Figure 2.3, is not monotone in x either.

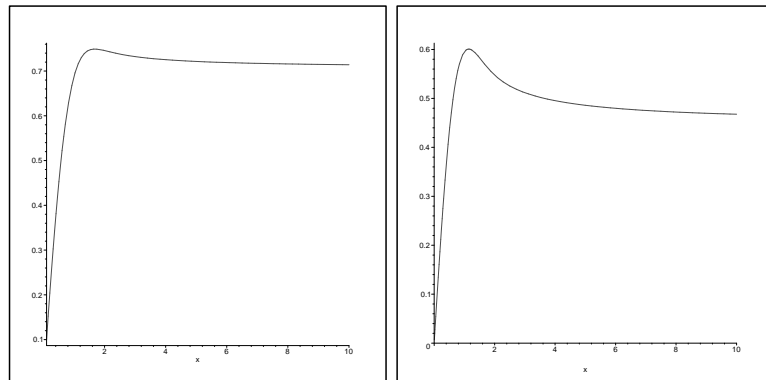

Figure 2.3: Left: Mean of $L(x)$ in function of x . Right: Mean of $P(x)$ in function of x .

2.3.2 Edge Distribution

Given $L(X) = r < |X|$, consider the angle $\theta(X)$ of the edge from X to $\mathcal{A}(X)$ in the tree. Using the property of the right part of Figure 2.2 that $\psi = \pi/2 - \phi/2$, we get that $\theta(X)$ is uniformly distributed on the interval: $(\pi + \arg(X) - \psi, \pi + \arg(X) + \psi)$, with $\cos \psi = \sin(\phi/2) = r/(2|X|)$, that is $\psi = \arccos \frac{r}{2|X|}$. Given $L(X) = |X|$, the angle $\theta(X)$ is $\pi + \arg(X)$.

The joint distribution function of $(L(X), \theta(X))$ will be denoted by $\xi_{|X|}(dr, d\theta)$ and is equal to

$$\begin{aligned} & \mathbf{1}(r \in (0, |X|)) \frac{d}{dr} M(|X|, r) e^{-M(|X|, r)} dr \times \\ & \mathbf{1}(\theta \in (\pi + \arg(X) - \psi, \pi + \arg(X) + \psi)) \frac{d\theta}{2\psi} \\ & + \delta_{|X|}(r) \delta_{\pi + \arg(X)}(\theta) e^{-M(|X|, |X|)}. \end{aligned} \quad (2.7)$$

The progress is defined as $P(X) = |X| - |\mathcal{A}(X)|$. The mean progress is plotted in function of $x = |X|$ in Figure 2.3.

2.3.3 Mean Degree of a Vertex

Degree at the Origin

The degree of the origin is

$$D(0) = \sum_{T \in \mathcal{N} \setminus \{0\}} \mathbf{1}(N(B(T, |T|) \cap B(0, |T|)) = 0).$$

Hence, using Campbell's formula, we get

$$\mathbb{E}D(0) = 2\pi \int_0^\infty e^{-r^2(2\pi/3 - \sin(2\pi/3))} r dr = \frac{\pi}{2\pi/3 - \sqrt{3}/2} \sim 2.56. \quad (2.8)$$

The following property is also of interest. The degree of a vertex in the minimal spanning tree is bounded, similarly we have

Lemma 2.3.1 *The degree of node 0 is upper bounded by 5 a.s.*

Proof. Order the points directly attached to the origin by increasing polar angle. Let X and Y denote two neighboring points in this sequence. Assume $|0\vec{X}| < |0\vec{Y}|$. Denote by ϕ the angle between these two vectors. We have

$$|X\vec{Y}|^2 = |0\vec{X}|^2 + |0\vec{Y}|^2 - 2|0\vec{X}||0\vec{Y}| \cos \phi.$$

Since Y is attached to the origin, necessarily $|X\vec{Y}|^2 > |0\vec{Y}|^2$, which implies that

$$2|0\vec{X}||0\vec{Y}| \cos \phi < |0\vec{X}|^2.$$

Using now the assumption that $|0\vec{X}| < |0\vec{Y}|$, we get $\cos \phi < 1/2$. Hence $|\phi| > \pi/3$. \square

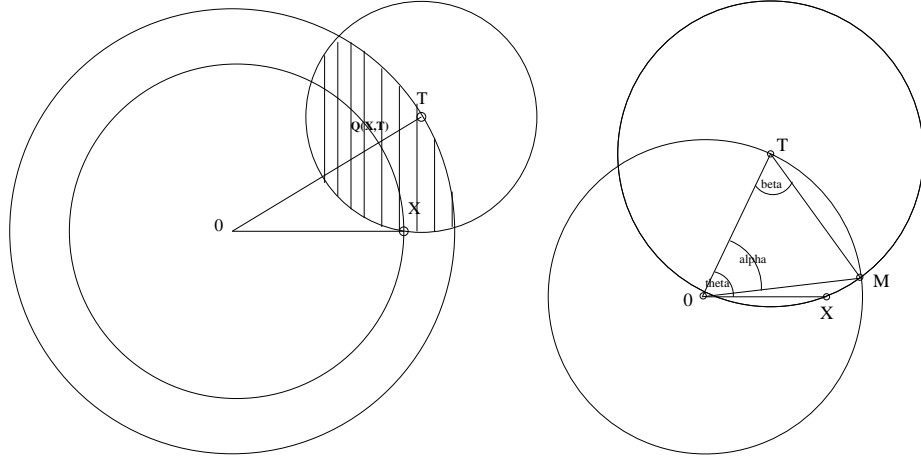

Figure 2.4: Left: $Q(t, \rho, \theta)$. Right: The α and β angles.

Degree outside the Origin

The degree of a vertex $X \neq 0$ is given by:

$$D(X) = 1 + \sum_{T \in N} \mathbf{1}(|T| \geq |X|) \mathbf{1}(N(B(T, |X - T|) \cap B(0, |T|) = 0) \mathbf{1}(0 \notin B(T, |X - T|)). \quad (2.9)$$

Indeed, a point T of modulus larger than $|X|$ shares an edge with X if and only if there is no point of smaller modulus closer from T than X .

Let $X \neq 0$, $|X| = x$, using Slivnyak-Campbell's Formula (see in Appendix §B.3) while taking the expectation of Equation (2.9),

$$\begin{aligned} \mathbb{E}D(X) &= 1 + \mathbb{E} \sum_{T \in N} \mathbf{1}(N(B(T, |X - T|) \cap B(0, |T|) = 0) \\ &\quad \mathbf{1}(x \leq |T|) \mathbf{1}(|T| > |X - T|) \\ &= 1 + \int_{\rho > x} \int_{-\arccos(\frac{x}{2\rho})}^{\arccos(\frac{x}{2\rho})} e^{-Q(x, \rho, \theta)} \rho d\rho d\theta, \end{aligned}$$

where $Q(x, \rho, \theta)$ is the dashed surface in Figure 2.4 for $X = xe_x$ and $T = (\rho, \theta)$. The condition that $|T| > |X - T|$ (or equivalently that θ belongs to the interval $(-\arccos(\frac{x}{2\rho}), \arccos(\frac{x}{2\rho}))$) translates the fact that the origin should not be contained in this lune. Hence

$$\mathbb{E}D(X) = 1 + \int_{\rho > x} \int_{-\arccos(\frac{x}{2\rho})}^{\arccos(\frac{x}{2\rho})} e^{-\frac{\rho^2}{2} |2\alpha - \sin 2\alpha|} e^{-\frac{\rho^2 + x^2 - 2\rho x \cos \theta}{2} |2\beta - \sin 2\beta|} \rho d\rho d\theta,$$

where α and β are the angles depicted in Figure 2.4.

If $u = \frac{\rho}{x}$, we have: $\cos \alpha = (1 - u^{-2})/2 + u^{-1} \cos \theta$ and $\beta = (\pi - \alpha)/2$. Finally,

$$\begin{aligned} \mathbb{E}D(X) &= 1 + 2x^2 \mathbf{1}_{u > 1} \int_0^{\arccos(\frac{1}{2u})} e^{-\frac{u^2 x^2}{2} (2\alpha - \sin 2\alpha)} \\ &\quad e^{-\frac{x^2}{2} (1 + u^2 - 2u \cos \theta) (\pi - \alpha - \sin \alpha)} u du d\theta. \end{aligned} \quad (2.10)$$

The mean degree is plotted in Figure 2.5.

The following lemma is remarkable in view of Lemma 2.3.1.

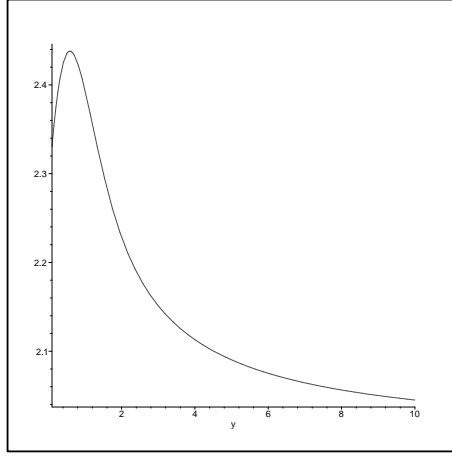

Figure 2.5: $\mathbb{E}D(X)$ as function of $x > 0$.

Lemma 2.3.2 *The degree of a node of the DSF is not bounded and in the RST a.s.*

$$\sup_{X \in \mathbb{N}} D(X) = +\infty.$$

Proof. Let $\mathcal{A}_{-e_x}(X)$ be the ancestor of X in the DSF with direction $-e_x$. The DSF built on the point set $\{X_n = (2^{-n}, 3^n), n \in \mathbb{N}\} \cup \{0\}$ gives: for all n , $\mathcal{A}_{-e_x}(X_n) = 0$, in particular the degree of the origin is infinite.

We now prove the second statement of the lemma.

Let $M \in \mathbb{N}^*$; for $n \geq 0$, we define $\mathbb{U}_n = [2^{-n} - \epsilon, 2^{-n} + \epsilon] \times [3^n - \epsilon, 3^n + \epsilon]$, $\mathbb{U}_{-1} = [-\epsilon, \epsilon] \times [-\epsilon, \epsilon]$, $A_M = B(0, 4^M) \setminus (\cup_{-1 \leq n \leq M} \mathbb{U}_n)$ and $E_M(X) = \{N(X + A_M) = 0, N(X + \mathbb{U}_n) = 1, -1 \leq n \leq M\}$. We have $\mathbb{P}(E_M(X)) = \delta > 0$ and if $|X - Y| > 2.4^M$, $E_M(X)$ and $E_M(Y)$ are independent (for ϵ is small enough).

For ϵ small enough, if $E_M(X)$ occurs, the point in $\mathbb{U}_{-1}(X)$ has degree at least M in \mathcal{T}_{e_x} . Similarly for the RST, if $|X|$ is large enough and if $E_M(X)$ occurs, the point in $\mathbb{U}_{-1}(X)$ has degree at least M in \mathcal{T}_0 .

Using the independence of the events $E_M(2k4^M e_x)$, $k \in \mathbb{N}$, we deduce that these events appear infinitely often and this concludes the proof. \square

2.3.4 Limit Distribution of an Edge Length

A direct computation gives:

$$\lim_{|X| \rightarrow +\infty} \mathbb{P}(L(X) \geq r) = \exp\left(-\frac{\pi r^2}{2}\right). \quad (2.11)$$

In particular,

$$\lim_{|X| \rightarrow +\infty} \mathbb{E}L(X) = \int_0^\infty e^{-\frac{\pi r^2}{2}} dr = \frac{1}{\sqrt{2}}. \quad (2.12)$$

By similar arguments, the asymptotic progress has for Laplace transform

$$\begin{aligned} \lim_{|X| \rightarrow +\infty} \mathbb{E}e^{-sP(X)} &= \frac{1}{\pi} \int_{r=0}^\infty \int_{\theta=-\pi/2}^{\pi/2} e^{-sr \cos \theta} \exp\left(-\frac{\pi r^2}{2}\right) \pi r dr d\theta \\ &= \int_{r=0}^\infty \int_{\theta=-\pi/2}^{\pi/2} e^{-sr \cos \theta} \exp\left(-\frac{\pi r^2}{2}\right) r dr d\theta. \end{aligned} \quad (2.13)$$

In particular, the mean asymptotic progress is

$$\lim_{|X| \rightarrow +\infty} \mathbb{E}P(X) = \frac{1}{\pi} \int_{r=0}^{\infty} \int_{\theta=-\pi/2}^{\pi/2} \exp\left(-\frac{\pi r^2}{2}\right) \cos \theta dr d\theta = \frac{\sqrt{2}}{\pi}. \quad (2.14)$$

L and P are distributed respectively as the length of the edge $(0, \mathcal{A}_{e_x}(0))$ and its x -coordinate in the DSF. This result is contained in Theorem 2.2.3 that we will prove in §2.3.6.

With the same reasoning applied to the degree, with $\mathcal{H}_{e_x}(0) = \{Y \in \mathbb{R}^2 : \langle e_x, Y \rangle > 0\}$, we get:

$$\begin{aligned} \lim_{|X| \rightarrow +\infty} \mathbb{E}D(X) &= 1 + \int_{\mathcal{H}_{e_x}(0)} \exp\left(-\frac{\pi|X|^2}{2}\right) dX \\ &= 1 + \int_{-\pi/2}^{\pi/2} \int_0^{+\infty} \exp\left(-\frac{\pi r^2}{2}\right) r dr d\theta \\ &= 2. \end{aligned}$$

2.3.5 Expectation of the Number of Crossing Edges

Let $x > 0$, $D(x) = D(xe_x)$ and $C(x)$ be the number of edges connecting a vertex inside $B(0, x)$ and a vertex outside. Almost surely, we can sort the points of N by increasing norm $0 = |X_0| < |X_1| < \dots$. We have:

$$C(|X_{n+1}|) = C(|X_n|) + D(X_{n+1}) - 2.$$

It follows that:

$$C(x) = D(0) + \sum_{|X_k| \leq x} (D(X_k) - 2).$$

Taking expectation, we deduce from Campbell's formula that

$$\mathbb{E}C(x) = \mathbb{E}D(0) + 2\pi \int_0^x (\mathbb{E}D(t) - 2) t dt,$$

In §2.3.4, we proved that $\lim_{x \rightarrow +\infty} \mathbb{E}D(x) = 2$ and $\mathbb{E}D(x) \geq 2$. Hence the evaluation of the asymptotic behavior of $\mathbb{E}C(x)$ requires that of $c = -\lim_{x \rightarrow +\infty} x^2 \mathbb{E}D(x)'$. We would then deduce: $\lim_{x \rightarrow +\infty} \mathbb{E}C(x)/x = c$. The exact computation of c is beyond the scope of this work.

Let γ be an arc on the circle of radius r and center 0 and let $C(r, \gamma)$ be the counting measure of the number of edges crossing γ . From the invariance by rotations of the PPP, we deduce that $\mathbb{E}C(r, \gamma) = l(\gamma) \frac{\mathbb{E}C(r)}{2\pi r}$, where $l(\gamma)$ is the length of the arc. In other words, the point process of edge crossings on the circle of radius r is stationary and with intensity $\mu(r) = \frac{\mathbb{E}C(r)}{2\pi r}$.

2.3.6 Proof of Theorem 2.2.3

Let $X \in \mathbb{R}^2 \setminus \{0\}$ and $\mathcal{A}_{-e_1}(X)$ be the ancestor of X in \mathcal{T}_{-e_1} with direction $-e_1$ (a given vector in S^1). We define θ as the angle between e_1 and X . The next lemma compares $\mathcal{A}(X)$ with $\mathcal{A}_{-e_1}(X)$ if we build \mathcal{T}_0 and \mathcal{T}_{-e_1} (with direction $-e_1$) on the same PPP, N^0 . The next lemma is analog of Lemma 1.2.2.

Lemma 2.3.3 *Let $X \in \mathbb{R}^2 \setminus \{0\}$, there exists C_1 such that*

$$\mathbb{P}(\mathcal{A}(X) \neq \mathcal{A}_{-e_1}(X)) \leq 1 \wedge C_1(1/|X| + \theta).$$

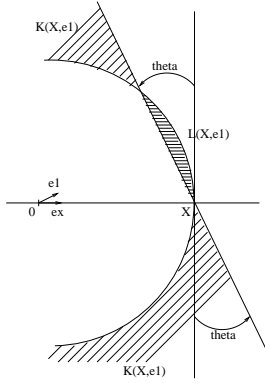

Figure 2.6: The sets $L(X, e_1)$ and $K(X, e_1)$.

Proof. Without loss of generality we suppose $X = xe_x$, $x > 0$ and $\theta > 0$. Let $K(X, e_1) = \{Y \in \mathbb{R}^2 : |Y| \geq |X|, \langle Y - X, e_1 \rangle \leq 0\}$ and $L(X, e_1) = \{Y \in \mathbb{R}^2 : |Y| \leq |X|, \langle Y - X, e_1 \rangle \geq 0\}$. These sets are depicted in Figure 2.6. We note that if $\mathcal{A}_{-e_1}(X) \notin K(X, e_1)$ and $\mathcal{A}(X) \notin L(X, e_1) \cup \{0\}$, then $\mathcal{A}_{-e_1}(X) = \mathcal{A}(X)$ and hence

$$\begin{aligned} \mathbb{P}(\mathcal{A}_{-e_1}(X) \neq \mathcal{A}(X)) &\leq \mathbb{P}(\mathcal{A}_{-e_1}(X) \in K(X, e_1)) \\ &\quad + \mathbb{P}(\mathcal{A}(X) \in L(X, e_1)) + \mathbb{P}(\mathcal{A}(X) = 0). \end{aligned}$$

The last term is easily computed: $\mathbb{P}(\mathcal{A}(X) = 0) = e^{-M(x,x)}$.

To upper bound the second term, we notice that $L(X, e_1)$ is contained in a cone of angle θ (see Figure 2.6); hence $\mathbb{P}(\mathcal{A}(X) \in L(X, e_1)) \leq \theta/\pi$.

The first term is upper bounded similarly. Let $K_-(X, e_1)$ be the lower part of $K(X, e_1)$; we have

$$\begin{aligned} \mathbb{P}(\mathcal{A}_{-e_1}(X) \in K(X, e_1)) &\leq 2 \mathbb{P}(\mathcal{A}_{-e_1}(X) \in K_-(X, e_1)) \\ &\leq \int_0^\infty 2\pi r e^{-\pi r^2} (\arcsin(\frac{r}{2x}) + \theta) dr \\ &\leq C_1(1/x + \theta). \end{aligned}$$

□

Theorem 2.2.3 is then a consequence of Lemma 2.3.3 and Theorem 1.2.3.

2.4 The Directed Path

The directed spanning forest is the key object for the asymptotic analysis of the RST. This section is dedicated to the analysis of the paths originating from some vertex. In this section, we will prove in particular the following theorem:

Theorem 2.4.1 \mathcal{A}_{-e_x} is a regenerative navigation, its regenerative time, θ , satisfies for some $s > 0$:

$$\mathbb{E} \exp(s\theta) < \infty.$$

In §1.4.5 we have already sketched a proof of this result. In this section, we will present an alternative proof. This proof is longer than the proof presented in §1.4.5, however it will give more results and it shows a nice connection with the theory of Markov chains on general state space.

2.4.1 The Underlying Markov Chain

We denote by $X_n = \mathcal{A}_{-e_x}^n(X_0)$ the n^{th} ancestor of point X_0 in the DSF with direction $-e_x$. The edge between X_i and X_{i-1} is $U_i = X_{i-1} - X_i$. Let $U_0 = -X_0$. From the definition of the tree, the x -coordinate of U_i is positive (almost-surely) and we have:

$$X_n = -\sum_{l=0}^n U_l \text{ and } X_n - X_k = -\sum_{l=k+1}^n U_l \text{ for } k < n.$$

The conditional probability of U_{n+1} given (U_0, \dots, U_n) can be analytically determined. Indeed let \mathcal{H} be the half-plane $(x > 0)$, $D_0 = \mathcal{H}$ and let

$$D_n = \mathcal{H} \cap \left\{ \bigcup_{k=0}^{n-1} B(X_n - X_k, |U_{k+1}|) \right\}^c \quad (2.15)$$

(see Figure 2.9). Given (U_0, \dots, U_n) , U_{n+1} admits the following density in polar coordinates:

$$\frac{d}{dr} |B(0, r) \cap D_n| e^{-|B(0, r) \cap D_n|} \frac{\mathbb{1}_{(r, \theta) \in D_n} r dr d\theta}{\nu_1(C(0, r) \cap D_n)}, \quad (2.16)$$

where ν_1 denotes the 1-dimensional Lebesgue measure and $C(X, r)$ the circle of radius r and center X .

Let D_n be the set given by Equation (2.15) for some fixed nodes X_0, \dots, X_n . The following two lemmas will have important applications.

Lemma 2.4.2 *Let (r_n, θ_n) denote the coordinates of U_n . Then for all $0 < \alpha < \pi/2$,*

$$\mathbb{P}(|\theta_n| < \alpha \mid D_{n-1}, r_n) \geq \frac{\alpha}{\pi}.$$

For $-\pi/2 \leq \alpha \leq \beta \leq \pi/2$, if the cone $\{(r, \theta); \theta \in [\alpha, \beta]\}$ is included in D_{n-1} , then

$$\mathbb{P}(\theta_n \in [\alpha, \beta] \mid D_{n-1}, r_n) \geq \frac{\beta - \alpha}{\pi}.$$

Proof. Fix r , in view of the geometry of D_n ,

$$d_{n-1}(r) = \left\{ \theta \in \left(-\frac{\pi}{2}, \frac{\pi}{2}\right) : (r, \theta) \in D_{n-1} \right\} = (-\theta_-(r), \theta_+(r)),$$

with $0 < \theta_{\pm} \leq \frac{\pi}{2}$.

From Equation (2.16), for a fixed r , the pdf of θ_1 conditioned on $r_n = r$ is uniform on $(-\theta_-(r), \theta_+(r))$. If $\theta_- < \alpha$ and $\theta_+ < \alpha$, then $\mathbb{P}(|\theta_n| < \alpha \mid r_n = r, D_{n-1}) = 1$; else, supposing for example $\theta_+ \geq \alpha$, then

$$\begin{aligned} \mathbb{P}(|\theta_n| < \alpha \mid r_n = r, D_{n-1}) &\geq \mathbb{P}(0 < \theta_n < \alpha \mid r_n = r, D_{n-1}) \\ &\geq \frac{\alpha}{\theta_+ + \theta_-} \geq \frac{\alpha}{\pi}. \end{aligned}$$

The proof of the second assertion is similar. □

Define the cones

$$\begin{aligned} c_{\alpha} &= \{x = (r, \theta) \in \mathbb{R}^2 : \theta \in [0, \alpha]\}, \text{ for } \alpha > 0 \\ c_{\alpha} &= \{x = (r, \theta) \in \mathbb{R}^2 : \theta \in (\alpha, 0]\}, \text{ for } \alpha < 0. \end{aligned}$$

Lemma 2.4.3 For all n ,

$$c_{\frac{\pi}{6}} \subset D_n \quad \text{or} \quad c_{-\frac{\pi}{6}} \subset D_n.$$

In particular if (r_n, θ_n) denote the coordinates of U_n , then

$$\mathbb{P}(r_n \geq u | X_{n-1}, X_{n-2}, \dots, X_0) \leq e^{-\frac{\pi u^2}{12}}.$$

Proof. The proof relies on a simple geometrical argument. Suppose first $n = 2$ and consider a circle C_2 of radius r_2 and center 0 (set to be X_1) and another circle C_1 of radius r_1 and center X_0 , $0 \in C_1$. In polar coordinates, X_0 is at (r_1, θ_1) and X_2 at (θ_2, r_2) . For $|\theta_2 - \theta_1| \leq \frac{\pi}{2}$, the equation of C_1 in polar coordinates is $r = 2r_1 \cos(\theta - \theta_1)$ (see Figure 2.7). The point X_2 is somewhere on C_2 ; suppose for example that it is in the orthant $\theta_2 \in [-\frac{\pi}{2}, 0]$. If $\theta_1 \notin [-\pi, -\frac{\pi}{2}]$ or $r_1 \geq 2r_2 \cos \theta_1$, then D_2 contains $c_{\frac{\pi}{2}}$.

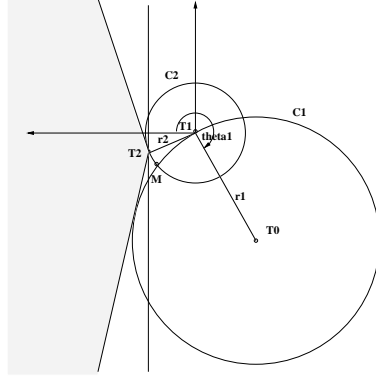

Figure 2.7: D_2 and the largest cone with origin X_2 contained in D_2

Suppose instead $\theta_1 \in [-\pi, -\frac{\pi}{2}]$ and $r_1 \leq 2r_2 \cos \theta_1$ (see Figure 2.7). We have to prove that the largest cone with origin X_2 contained in D_2 contains $c_{\frac{\pi}{6}}$ or $c_{-\frac{\pi}{6}}$.

The worst case is when X_2 is at M , defined as the intersection of C_1 and C_2 in the orthant $\theta \in [-\frac{\pi}{2}, 0]$. We have $M = (r_2, \phi)$, with $\phi = \theta_1 + \arccos(\frac{r_2}{2r_1})$. In this case, an easy calculation shows that the largest cone contained in D_2 with origin $M = X_2$ is $\{x = M + (r, \theta) : \theta \in (-\frac{\pi}{2} - \theta_1 + 2\phi, \frac{\pi}{2} + \phi)\}$. The worst case is reached when $\phi = \frac{\theta_1}{3}$, since $\theta_1 \geq -\pi$. We deduce that $\max(\frac{\pi}{2} + \theta_1 - 2\phi, \frac{\pi}{2} + \phi) \geq \frac{\pi}{6}$.

This concludes the proof for $n = 2$. For $n \geq 3$, the largest cone contained in D_n with origin X_n is tangent to (at most) two circles, and the same conclusion holds. \square

A sample path together with the associated exclusion discs is given in Figure 2.8.

From Equation (2.16), the process $\{U_n\}, n \in \mathbb{N}$ is not Markov. We may circumvent this difficulty by defining:

$$\tau_{n+1} = \inf\{m > \tau_n : \mathcal{H} \cap \left\{ \bigcup_{k=\tau_n-1}^{m-2} B(X_m - X_k, |U_{k+1}|) \right\}^c = \emptyset\}, \quad (2.17)$$

with $\tau_0 = 1$.

Each τ_n is a stopping time with respect to the internal history of $\{U_n\}$. We call these times *markovian times* (we will soon see why).

Let $L_i = |U_{i+1}|$ denote the length of the edge from X_i to X_{i+1} and P_i the absolute value of the progress realized by this edge.

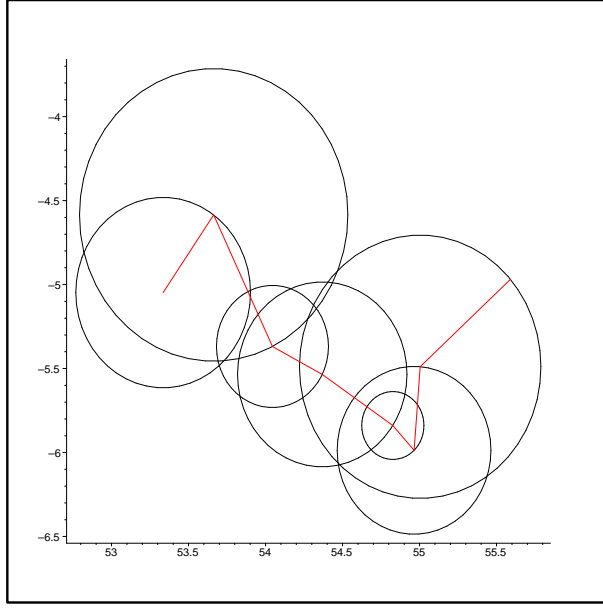

Figure 2.8: A sample path and the associated discs.

The projection of $\mathcal{H} \setminus D_{\tau_0} = \mathcal{H} \cap \{B(X_1 - X_0, |U_1|)\}$ on the x -axis is $\xi_1 = L_0 - P_0$. More generally, denote by ξ_n the projection of $\mathcal{H} \setminus D_n = \mathcal{H} \cap \{\bigcup_{k=0}^{n-1} B(X_n - X_k, |U_{k+1}|)\}$ on the x -axis. This sequence satisfies the recurrence relation

$$\xi_{n+1} = \max(\xi_n - P_n, L_n - P_n), \quad n \geq 1, \quad (2.18)$$

so that for all $n \geq 1$,

$$\xi_n = \max_{1 \leq i \leq n} (L_{i-1} - \sum_{k=i-1}^{n-1} P_k).$$

and the markovian time τ_1 is then simply rewritten as:

$$\tau_1 = \inf\{m > 1 \mid P_m \geq \xi_m\}.$$

For instance, on the realization of Figure 2.9, $\tau_1 = 4$.

Lemma 2.4.4 *For all $m \geq 1$,*

$$\mathbb{P}(\tau_m - \tau_{m-1} > n \mid D_{\tau_0}) \leq C_1 e^{-C_0 n} \quad \text{and} \quad \mathbb{P}(\tau_m > \beta m \mid D_{\tau_0}) \leq C_1 e^{-C_0 m},$$

for some positive constants β, C_0, C_1 (depending on D_{τ_0}), so that in particular τ_m is a.s. finite.

Proof. This result follows from the statement of Lemma C.1 (in Appendix). We explain the connection between the setting Lemma C.1 and the current setting in the particular case $m = 0$.

We first show that for all n , the random variable ξ_n defined in (2.18) is bounded from above by $\tilde{\xi}_n$, where $\tilde{\xi}_n$ is the maximal residual service time just before the n -th arrival in a GI/GI/ ∞ queue with i.i.d. service times $\{\tilde{L}_n\}$ and i.i.d. inter-arrival times $\{\tilde{P}_n\}$ where:

- \tilde{L}_i is the distance from X_i to the closest point in the cone (either $c_{\frac{\pi}{6}}$ and $c_{\frac{-\pi}{6}}$) that is fully included in D_i if there is only one such cone. If both $c_{\frac{\pi}{6}}$ and $c_{\frac{-\pi}{6}}$ are included in D_i , then one selects one of them at random;

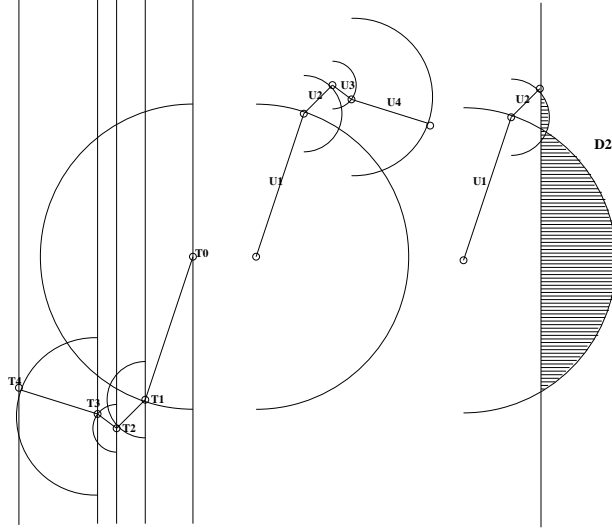

Figure 2.9: The process X_0, X_1, \dots, X_n , the associated U_1, \dots, U_n and in dashed $\mathcal{H} \setminus D_2$.

- \tilde{P}_i is defined as follows: one samples an independent Poisson point process N' of intensity 1 and one picks the point of

$$((N \cap D_i) \cup (N' \cap D_i^c \cap \mathcal{H})) \cap B(X_i, \tilde{L}_i)$$

which has the smallest progress from X_i .

Since for all i , $L_i \leq \tilde{L}_i$ and $P_i \geq \tilde{P}_i$ a.s. an immediate induction gives $\xi_i \leq \tilde{\xi}_i$ a.s., where $\tilde{\xi}_i$ is defined by the same recursion but with \tilde{L}_i and \tilde{P}_i in place of L_i and P_i . This recursion is that of the maximal residual service time just before the arrivals in a GI/GI/ ∞ queue (see in Appendix §C.2).

Using a Loynes type argument (see in Appendix §C.1), the sequence $\{\tilde{\xi}_i\}$ is easily seen to be stochastically monotone in i and to converge weakly to a non degenerate limit $\tilde{\xi}$ when i tends to infinity.

Pick a such that $\mathbb{P}(\tilde{\xi} \leq a) = \eta > 0$. Let (r_n, θ_n) be the polar coordinates of U_n . In view of the remark preceding the lemma,

$$\begin{aligned} \mathbb{P}(\tau_1 = m \mid D_0) &\geq \mathbb{P}(\xi_m \leq a) \mathbb{P}(r_{m+1} \cos(\theta_{m+1}) \geq a \mid D_m) \\ &\geq \mathbb{P}(\tilde{\xi} \leq a) \mathbb{P}(r_{m+1} \cos(\theta_{m+1}) \geq a \mid D_m). \end{aligned}$$

Let $c(r, \alpha)$ denote the set $\{(\rho, \theta) : \rho < r; |\theta| < \alpha\}$. From Lemma 2.4.2, for all sets D_m , for all $\alpha \in (0, \frac{\pi}{2})$:

$$\begin{aligned} \mathbb{P}(r_{m+1} \cos \theta_{m+1} \geq a \mid D_m) &\geq \mathbb{P}(r_{m+1} \cos \theta_{m+1} \geq a; |\theta_n| < \alpha \mid D_m) \\ &\geq \frac{\alpha}{\pi} e^{-\nu_2(c(\frac{a}{\cos \alpha}, \alpha) \cap D_m)} \\ &\geq \frac{\alpha}{\pi} e^{-\frac{a^2 \alpha}{\cos^2 \alpha}} = \mu > 0. \end{aligned}$$

Let

$$\tilde{\tau}_1 = \inf\{m > 1 \mid \tilde{P}_m \geq \tilde{\xi}_m\}.$$

Since $\tau_1 \leq \tilde{\tau}_1$, in order to prove the finiteness of τ_1 (or the exponential bound on the tail of its law), it is enough to prove this property on $\tilde{\tau}_1$. \square

For $n \geq 1$, we define the path between two successive stopping times as the point process:

$$\Phi_n = \{0, X_{\tau_{n-1}} - X_{\tau_{n-1}+1}, \dots, X_{\tau_n} - X_{\tau_n}\} \quad (2.19)$$

and we define $\Phi_0 = \{0, X_0 - X_1\}$. From Lemma 2.4.4, for all n , Φ_n is a finite point process on $\mathcal{X} = \mathbb{R}_+ \times \mathbb{R}$. We endow the set $\mathcal{N}_{\mathcal{X}}$ of finite point processes on \mathcal{X} with the usual weak topology, $(\mathcal{N}_{\mathcal{X}}, \mathcal{B}(\mathcal{N}_{\mathcal{X}}))$, making a complete metric space (see Daley and Vere-Jones [55] for details).

Theorem 2.4.5 $\{\Phi_n\}, n \in \mathbb{N}$, is a positive and uniformly ergodic Harris chain.

The proof is organized in several steps. All definitions on Markov Chains are taken from Meyn and Tweedie [123].

Markov Property Almost surely, we may write: $\Phi_n = \{0, X_1^n, \dots, X_{N_n}^n\}$, where the x -coordinates of the X_i^n are increasing. By the definition of τ_n , for all n , we have:

$$D_{\tau_n} = \mathcal{H} \cap B(-U_{\tau_n}, |U_{\tau_n}|)^c.$$

It follows from Equation (2.16) that the law of $U_{\tau_{n+1}} = X_1^n$ depends on Φ_0, \dots, Φ_n only through $U_{\tau_n} = X_{\tau_{n-1}} - X_{\tau_n}$.

More generally, since $\mathcal{H} \cap B(X_n - X_k, |U_{k+1}|) = \emptyset$ implies $\mathcal{H} \cap B(X_m - X_k, |U_{k+1}|) = \emptyset$ for $m \geq n$, it follows that for all $m \geq \tau_n$,

$$D_m = \mathcal{H} \cap \left\{ \bigcup_{k=\tau_n-1}^{m-1} B(X_m - X_k, |U_{k+1}|) \right\}^c,$$

which depends only on U_{τ_n}, \dots, U_m . In particular, for all n ,

$$\mathbb{P}(\Phi_{n+1} \in \cdot | \Phi_0, \dots, \Phi_n) = \mathbb{P}(\Phi_{n+1} \in \cdot | U_{\tau_n}) = \mathbb{P}(\Phi_{n+1} \in \cdot | \Phi_n),$$

since U_{τ_n} is a functional of Φ_n only, which completes the proof of the Markov Property.

In what follows, it will be useful to consider more general initial conditions than the two-point Φ_0 defined above. Any finite point process Φ on \mathcal{X} with $\Phi = \{0, X_1^0, \dots, X_N^0\}$ and satisfying the constraint

$$D_N = \mathcal{H} \cap B(-U_N, |U_N|)^c$$

is an acceptable initial condition when taking $\tau_0 = N$. A special case is that where $\Phi = \{0\}$ where $N = 0$ and $D_0 = \mathcal{H}$.

In what follows, for a point pattern Φ as above, we will also use the notation $X_i(\Phi)$ for the i -th point, $N(\Phi)$ for the number of points, $D(\Phi)$ for the set D_N .

As commonly done in Markov chain theory, we will denote by \mathbb{P}_{Φ} the probability $\mathbb{P}(\cdot | \Phi_0 = \Phi)$ and by \mathbb{P}_{Φ}^n the probability $\mathbb{P}(\Phi_n \in \cdot | \Phi_0 = \Phi)$, with $\Phi = \{0, X_1, \dots, X_N\}$ a finite point process satisfying the above property. In particular, \mathbb{P}_0 (or \mathbb{P}_0^n) will denote the probability measure of the process conditioned on $\Phi_0 = \{0\}$.

Note that \mathbb{P}_{Φ} depends on Φ only through $D(\Phi)$.

Irreducibility and Aperiodicity For $A \in \mathcal{B}(\mathcal{N}_{\mathcal{X}})$, define:

$$\sigma_A = \min\{n \geq 1 : \Phi_n \in A\} \quad (2.20)$$

and

$$L(\Phi, A) = P(\sigma_A < \infty | \Phi_0 = \Phi).$$

The irreducibility of a Markov Chain on $\mathcal{N}_{\mathcal{X}}$ relies on the existence of a measure ν on $\mathcal{B}(\mathcal{N}_{\mathcal{X}})$ such that, for all A in $\mathcal{B}(\mathcal{N}_{\mathcal{X}})$:

$$\nu(A) > 0 \text{ implies } L(\Phi, A) > 0 \text{ for all } \Phi \in \mathcal{N}_{\mathcal{X}}. \quad (2.21)$$

For all sub σ -algebras \mathcal{G} of $\mathcal{B}(\mathcal{N}_{\mathcal{X}})$, let $\mathbb{P}_{\Phi}^1|_{\mathcal{G}}$ denote the restriction of \mathbb{P}_{Φ}^1 to \mathcal{G} .

Let \mathcal{F} denote the sub σ -algebra of $\mathcal{B}(\mathcal{N}_{\mathcal{X}})$ generated by the set $\{N(\Phi) = 1\} \cap \{X_1(\Phi) \in B\}$, $B \in \mathcal{O}^+$, where \mathcal{O}^+ denotes the positive orthant $\mathbb{R}_+ \times \mathbb{R}_+$. We choose ν to be $P_0^1|_{\mathcal{F}}$.

As already pointed out, \mathbb{P}_{Φ}^1 depends on Φ only through $D(\Phi)$. In view of Equation (2.16), if $D(\Phi) \cap \mathcal{O}^+ = \mathcal{O}^+$, then $\mathbb{P}_{\Phi}^1|_{\mathcal{F}}$ and $P_0^1|_{\mathcal{F}}$ are equivalent measures. So if $D(\Phi) \cap \mathcal{O}^+ = \mathcal{O}^+$ and $\mathbb{P}_0^1(A) > 0$, for some $A \in \mathcal{F}$, we have then $\mathbb{P}_{\Phi}^1(A) > 0$ so that $L(\Phi, A) > 0$.

Consider now the case where $D(\Phi) \cap \mathcal{O}^+ \neq \mathcal{O}^+$. The first point of Φ_1 is $X_1(\Phi_1) = U_{\tau_0+1}$. Let (R_1, Θ_1) be the coordinates of $X_1(\Phi_1)$. Let $(0, \xi)$ denote the projection on the x axis of the set $\mathcal{H} \setminus D(\Phi)$. From Equation (2.16), $\mathbb{P}(R_1 \cos \Theta_1 > \xi, \Theta_1 > 0) > 0$. If $R_1 \cos \Theta_1 > \xi$, $\tau_0 + 1$ is a Markovian time, so that $\tau_1 = \tau_0 + 1$, and $D(\Phi_1) = \mathcal{H} \cap B(-U_{\tau_1}, |U_{\tau_1}|)^c$. If in addition $\Theta_1 > 0$, $D(\Phi_1) \cap \mathcal{O}^+ = \mathcal{O}^+$, from what precedes, for $A \in \mathcal{F}$ and such that $P_0^1(A) > 0$, then $P_{\Phi}^2(A) > 0$, which implies $L(\Phi, A) > 0$.

The irreducibility is thus proved. The proof of the aperiodicity is along the same lines.

Small Set A set $S \in \mathcal{B}(\mathcal{N}_{\mathcal{X}})$ is small if there exists an integer $n > 0$ and a non-trivial measure ν on $\mathcal{B}(\mathcal{N}_{\mathcal{X}})$ such that for all $A \in \mathcal{B}(\mathcal{N}_{\mathcal{X}})$

$$\inf_{\Phi \in S} P_{\Phi}^n(A) \geq \nu(A). \quad (2.22)$$

For $\Phi = \{0, X_1, \dots, X_{\tau(\Phi)}\}$ in $\mathcal{N}_{\mathcal{X}}$, we define $(R(\Phi), \Theta(\Phi))$ as the coordinates of $X_{\tau} - X_{\tau-1}$. For $r > 0$ and $0 < \alpha < \pi/2$, let $\mathcal{S}(r, \alpha) \in \mathcal{B}(\mathcal{N}_{\mathcal{X}})$ be defined by

$$\mathcal{S}(r, \alpha) = \{\Phi \in \mathcal{N}_{\mathcal{X}} : |\Theta(\Phi)| \leq \alpha, R(\Phi) \leq r\}. \quad (2.23)$$

Let \mathcal{G} denote the sub σ -algebra of $\mathcal{B}(\mathcal{N}_{\mathcal{X}})$ generated by the sets $\{\tau(\Phi) = 1\} \cap \{X_1(\Phi) \in B\}$, $B \in C_{\alpha}$, where C_{α} denotes the cone

$$C_{\alpha} = \{(r, \theta) \in \mathbb{R}^2 : \theta \in [-\pi/2 + \alpha, \pi/2 - \alpha]\}.$$

We now prove that

$$\mathcal{S} = \mathcal{S}(r, \alpha) \quad (2.24)$$

is a small set for $\nu = g(r, \alpha)P_0^1|_{\mathcal{G}}$ and $n = 1$, where $g(r, \alpha)$ is a positive constant to be determined below.

From Equation (2.16), for all $\Phi \in \mathcal{S}$,

$$\begin{aligned} \mathbb{P}_{\Phi}(X_1(\Phi_1) \in C_{\alpha}, \tau(\Phi_1) = 1) &= \mathbb{P}_{\Phi}(|\Theta_1| \leq \pi/2 - \alpha, R_1 \cos \Theta_1 \geq r) \\ &\geq P_0(|\Theta_1| \leq \pi/2 - \alpha, R_1 \cos \Theta_1 \geq r) \\ &\geq \frac{\pi/2 - \alpha}{\pi} e^{-\frac{r^2(\pi/2 - \alpha)}{\sin^2 \alpha}} = g(r, \alpha) > 0. \end{aligned}$$

Note also that from Equation (2.16), for all $B \subset \mathcal{E}$,

$$\begin{aligned} &\mathbb{P}_{\Phi}(X_1 \in B \mid |\Theta_1| \leq \pi/2 - \alpha, R_1 \cos \Theta_1 \geq r) \\ &= P_0(X_1(\Phi_1) \in B \mid |\Theta_1| \leq \pi/2 - \alpha, R_1 \cos \Theta_1 \geq r). \end{aligned}$$

These two remarks imply that for all $A \in \mathcal{G}$

$$\mathbb{P}_{\Phi}(\Phi_1 \in A) \geq g(r, \alpha)P_0(\Phi_1 \in A),$$

which concludes the proof.

Positivity and Uniform Ergodicity Let $\sigma_{\mathcal{S}} = \inf\{n \geq 1 : \Phi_n \in \mathcal{S}\}$ be the first return time to \mathcal{S} with \mathcal{S} defined as above.

Lemma 2.4.6 For all $r > 0$, $\mathcal{S} = \mathcal{S}(r, \pi/6)$, we have $\sup_{\Phi} E_{\Phi} \sigma_{\mathcal{S}} < \infty$. More precisely $\sup_{\Phi} \mathbb{P}(\sigma_{\mathcal{S}} > n) \leq (1 - \delta(r))^n$, with $\delta(r) = (1 - e^{-\pi r^2/12})/6$.

Proof. From Lemma 2.4.2 and Lemma 2.4.3, for all n ,

$$\mathbb{P}(r_n \leq r, |\theta_n| \leq \frac{\pi}{6} \mid X_{n-1}, \dots, X_0) \geq \frac{1}{6}(1 - e^{-\pi r^2/12}).$$

Hence, for all Φ ,

$$\mathbb{P}_{\Phi}(R(\Phi_1) \leq r, |\Theta(\Phi_1)| \leq \frac{\pi}{6}) \geq \frac{1}{6}(1 - e^{-\pi r^2/12}), \quad (2.25)$$

from which one easily deduces that $\sup_{\Phi} E_{\Phi} \sigma_{\mathcal{S}} < \infty$. \square

In view of Theorem 10.4.10 and 16.0.2 of [123], $\{\Phi_n\}$ is positive and uniformly ergodic.

2.4.2 Limit Theorems

We follow the approach of Athreya and Ney (see [13]). Since the Markov Chain Φ is positive Harris recurrent, we can build an increasing sequence of finite stopping times N_k (on an enlarged probability space) such that $N_0 = 0$ and

$$\mathbb{P}_{\Phi_0}(\Phi_n \in A, N_k = n) = \mu(A) \mathbb{P}_{\Phi_0}(N_k = n), \quad (2.26)$$

where μ is a probability measure on $\mathcal{N}_{\mathcal{X}}$. Therefore, $N_k - 1$ is a regenerative time: the sequences $(\Phi_{n+N_k}), n \in \mathbb{N}$, and $(\Phi_n), 0 \leq n \leq N_k - 1$, are independent.

Lemma 2.4.6 implies that $N_k - N_{k-1}$ is stochastically dominated by a geometric law. We define $\theta_k = \tau_{N_k}$ with τ_n defined in (2.19); since $\xi_{\theta_k} \leq r$ (with ξ_n defined in (2.18)), from Lemma 2.4.4, $\mathbb{P}(\theta_{k+1} - \theta_k \geq t \mid \mathcal{F}_{\theta_k}) \leq C_1 \exp(-C_0 k)$, for some positive constants. We deduce the proof of Theorem 2.4.1.

For $\Phi = \{0, X_1, \dots, X_{\tau}\}$ in $\mathcal{N}_{\mathcal{X}}$, we define $f(\Phi) = \sum_{n=1}^{\tau} \max(1, |X_n|^{\alpha})$, $\alpha > 1$. Using the upper bounds of Lemma 2.4.4 and Lemma 2.4.3, we get

$$\sup_{x \in \mathcal{S}} E_x \left(\sum_{k=0}^{\sigma_{\mathcal{S}}-1} f(\Phi_k) \right) < \infty, \quad (2.27)$$

where $\sigma_{\mathcal{S}}$ is defined by Equation (2.20) and \mathcal{S} is the small set defined above.

Let Π be the invariant distribution of the Markov chain. We define the *invariant distribution* of the edge process $X_0 - X_1, \dots, X_{n-1} - X_n, \dots$ as:

$$\pi(A) = E_{\Pi}(\tau)^{-1} E_{\Pi} \left(\sum_{l=0}^{\tau-1} \mathbf{1}((X_{l+1} - X_l) \in A) \right), \quad A \in \mathbb{R}^2. \quad (2.28)$$

We may now deduce the limit theorem.

Theorem 2.4.7 For all measurable functions g , let $S_n = \sum_{k=0}^{n-1} g(X_{k+1} - X_k)$. If $g(x) \leq \max(C, |x|^{\alpha})$ for $C > 0$, $\alpha > 0$ then a.s.:

$$\lim_{n \rightarrow \infty} \frac{S_n}{n} = E_{\Pi}(\tau)^{-1} E_{\Pi} \left(\sum_{l=0}^{\tau-1} g(X_{l+1} - X_l) \right) = \pi(g),$$

Let $G(\Phi) = \sum_{l=0}^{\tau-1} (g(X_{l+1} - X_l) - \pi(g))$; if

$$\gamma^2 = E_{\Pi}(G(\Phi_0)^2) + 2 \sum_{k=1}^{\infty} E_{\Pi}(G(\Phi_0)G(\Phi_k)) > 0,$$

then a central limit theorem also holds:

$$\frac{1}{\gamma\sqrt{n}}(S_n - \pi(g)) \xrightarrow{d} \mathcal{N}(0, 1).$$

If $\gamma = 0$ then $\frac{1}{\sqrt{n}}(S_n - \pi(g))$ tends a.s. to 0.

This theorem characterizes the asymptotic behavior of a path in the directed spanning forest.

Proof. Theorem 2.4.7 is a direct application of Theorem 17.0.1 of [123]. Theorems 14.2.3, 14.2.4 and 14.3.7 of [123] along with Equation(2.27) ensure that all requirements are fulfilled. \square

Corollary 2.4.8 *There exists positive constants p , p_y and for $\alpha > 0$, l_α such that*

$$\lim_{n \rightarrow \infty} \frac{1}{n} \sum_{k=0}^{n-1} \langle X_k - X_{k+1}, e_x \rangle = p_x = p, \quad (2.29)$$

$$\lim_{n \rightarrow \infty} \frac{1}{n} \sum_{k=0}^{n-1} |\langle X_k - X_{k+1}, e_y \rangle| = p_y, \quad (2.30)$$

$$\lim_{n \rightarrow \infty} \frac{1}{n} \sum_{k=0}^{n-1} |X_{k+1} - X_k|^\alpha = l_\alpha. \quad (2.31)$$

By simulation of 20000 hops of the chain, one obtains that $p \sim .504$, $p_y \sim .46$ and $l_1 \sim .75$. The value of p is significantly larger than the mean asymptotic progress as evaluated in (2.14). The latter can be seen as the expectation of the progress from point $X_0 = 0$ under the Palm probability of the Poisson point process N , whereas p is the expectation of the progress under another measure: for all n , let $P_n = |U_n \cdot e_x|$ be the progress from the n -th ancestor of point $X_0 = 0$. From the above analysis, the law of P_n under the Palm probability of N converges weakly to a limit when n tends to infinity, and p is the mean of the limit law. A similar observation holds for l_1 when compared to (2.12): as it is the case for progress, on a long path, the magnitude of the hop from a point to its ancestor is "boosted" by the presence of its offspring.

Note that it is also possible to derive a functional central limit theorem for the sequence $(X_k)_k$ from Theorem 17.4.4 of [123].

Remark 2.4.9 An interesting question along the line of [64] and [71] is whether the Directed Spanning Forest is almost surely a tree, namely whether two sequences of ancestors coalesce almost surely (in dimension 2 and 3). Similarly, every vertex has almost surely a finite number of successors. One can also expect that the Directed Spanning Tree converges toward the Brownian Web, (see [154], [63], [65]). If this holds true, then the Directed Spanning Tree has only one semi-infinite path whereas in view of Theorem 2.2.1, the RST has a semi-infinite path in every direction. The edge process of successive ancestors in the RST converges in some sense toward the edge process of successive ancestors in the Directed Spanning Tree; however the two trees have a completely different topology.

2.4.3 Maximal Deviation

We end this section with a result on the deviation of the path from its mean. In this paragraph, we assume that $X = xe_x$, $x > 0$. Let $\pi_{-e_x}(X)$ denote the path from X in the DSF with direction $-e_x$; $\pi_{-e_x}(X)$ may be seen as a piecewise linear curve $(t, Y(t))_{t \leq x}$ in \mathbb{R}^2 . The maximal deviation of this curve between x' and x with $x' \leq x$ is defined as

$$\Delta(x, x') = d(\pi_{-e_x}(xe_x), \overline{0X}) = \sup_{t \in [x', x]} |Y(t)|. \quad (2.32)$$

Theorem 2.4.10 *For all $x' \leq x$, for all $\epsilon > 0$ and all integers n ,*

$$\mathbb{P}(\Delta(x, x') \geq |x - x'|^{\frac{1}{2} + \epsilon}) = O(|x - x'|^{-n}).$$

This theorem is a consequence of Theorem 2.4.1 and Corollary 1.5.13 (which is stated for a navigation but extend similarly to a directed navigation).

2.5 The Radial Path

Let $\pi_0(X)$ denote the path from X to the origin in the RST. This path (a sample of which is depicted in Figure 2.10) may be seen as a piecewise linear curve in \mathbb{R}^2 . We denote by $H(X)$ the generation of X in the RST. As for the DSF, we will denote by $X_0, X_1, \dots, X_{H(X)} = 0$ the sequence of the successive ancestors of $X_0 = X$ in the RST. In this section we will assume that

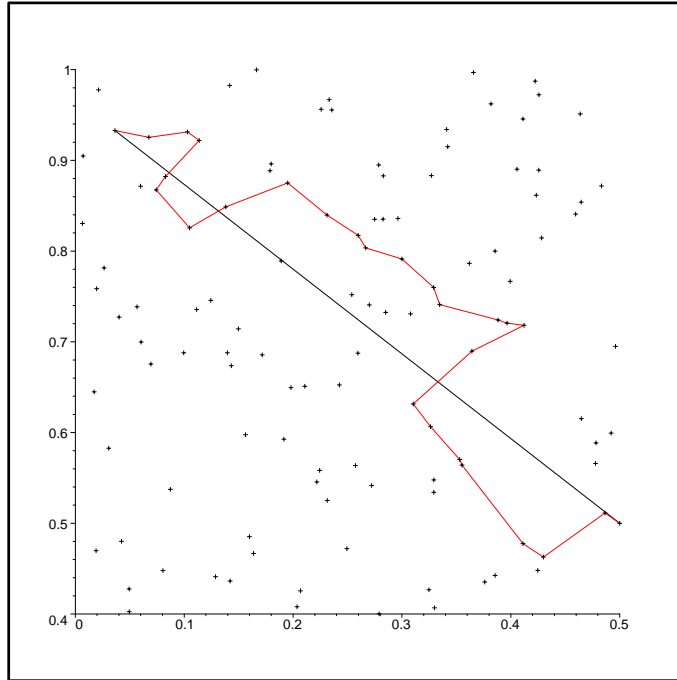

Figure 2.10: An example of radial path (with its origin in $(1/2, 1/2)$). The initial point is of generation 26.

$X = xe_x$ with $x > 0$. One of the important differences with the path $\pi_0(X)$ of the directed spanning tree studied in the last section is that the sequence $(X_k \cdot e_x)_{k \in \mathbb{N}}$ is not necessarily a monotone sequence in k .

2.5.1 Maximal Deviation of the Radial Path

The aim of this paragraph is to bound the tail of the distribution of:

$$\Delta(X) = \Delta(x) = d(\pi_0(X), \overline{0x}) = \sup_{X \in \pi_0(X)} \inf_{X' \in \overline{0x}} |X - X'|, \quad (2.33)$$

where $\overline{0x}$ denotes the x -axis.

The machinery developed in Chapter 1, Section 1.5 (and in particular Corollary 1.5.13) can be used to obtain directly the result. We will instead present an alternative proof which does not use the fact that the radial navigation is regenerative. For all $t \in \mathbb{R}$, we define:

$$\begin{aligned} Y(t) &= \max(0, \sup\{y : (t, y) \in \pi_0(X)\}) \\ Z(t) &= \max(0, -\inf\{y : (t, y) \in \pi_0(X)\}), \end{aligned}$$

where the supremum over an empty set is taken to be $-\infty$. Notice that $Y(x) = 0$, $Y(t) = 0$ for $t \notin [-x, x]$, $\sup_{t \in \mathbb{R}} Y(t) = \sup\{X.e_y : X \in \pi_0(X)\}$ and:

$$\Delta(x) = \max(\sup_{t \in \mathbb{R}} Y(t), \sup_{t \in \mathbb{R}} Z(t)).$$

Now let $\hat{\pi}_0(X)$ denote the path from $X = xe_x$ in the directed spanning tree with direction $-e_x$, when building this tree on the same point process as the RST, but with all points below the line $\overline{0x}$ removed. The path $\hat{\pi}_0(X)$ may be parameterized by the x -coordinate of the process

$$\hat{\pi}_0(X) = \{(t, \hat{Y}(t)), t \leq x\}.$$

The key result of this subsection is the following:

Theorem 2.5.1 *For all $t \leq x$, $Y(t) \leq \hat{Y}(t)$.*

Proof. The proof of this result is in two steps.

We first prove that if the two curves share a common point T of the point process, namely if $(t, Y(t)) = (t, \hat{Y}(t)) = T$ for some $T \in N$ (like for instance $T = X$), then the segment of $\pi_0(X)$ from T to its ancestor is never above that from T to its ancestor in $\hat{\pi}_0(X)$.

Let $y = Y(t) = \hat{Y}(t) \geq 0$. The ancestor of T in the radial (resp. directed) tree is denoted by S (resp. \hat{S}). If $S = \hat{S}$, then the segments from T to its ancestor coincide in the two trees and the property is proved. If $S \neq \hat{S}$ and $S \in L_-$, the property also holds since $\hat{S} \in L_-^c$.

Let $\mathcal{H}^-(t)$ denote the left half-plane ($x < t$). If $S \neq \hat{S}$ and $S \in L_-^c$, then $\hat{S} \in \mathcal{H}^-(t) \setminus B(0, |T|)$, and since $\hat{S} \in L_-^c$, \hat{S} is necessarily above $B(0, |T|)$, the property is proved in this case too.

To complete the proof, we now show that the curve $\pi_0(X)$ cannot cross the curve $\hat{\pi}_0(X)$ to enter the region above $\hat{\pi}_0(X)$ at a location which is not a point of the point process. Suppose that the two curves intersect as indicated and that the intersection takes place between nodes $\hat{X}_i = (\hat{x}_i, \hat{y}_i)$ and $\hat{X}_{i+1} = (\hat{x}_{i+1}, \hat{y}_{i+1})$ in the directed spanning tree and between nodes $X_j = (x_j, y_j)$ and $X_{j+1} = (x_{j+1}, y_{j+1})$ in the RST. Because of the assumptions on the intersection, one can assume $\hat{x}_i \geq \hat{x}_{i+1}$ and $x_j \geq x_{j+1}$. Let L denote the closed half plane below the line (X_j, X_{j+1}) . We have $\hat{X}_i \in L^c$ and $\hat{X}_{i+1} \in L$.

Suppose that $\hat{x}_i < x_j$. The ancestors of \hat{X}_i , \hat{X}_{i+1} and X_j are both in $\mathcal{H}^-(\hat{x}_i)$. From the construction of the directed spanning tree, for any point X of the point process lying in $H(\hat{x}_i)$, $\hat{X}_{i+1} \in B(\hat{X}_i, |\hat{X}_i - X|)$. Using the fact that $\hat{x}_i < x_j$ and $y_j < \hat{y}_j$, we get that $B(\hat{X}_i, |\hat{X}_i - X_{j+1}|) \cap \mathcal{H}^-(\hat{x}_i) \cap L \subset B(X_j, |X_j - X_{j+1}|) \cap \mathcal{H}^-(\hat{x}_i) \cap L$. Now, by construction of the RST, $B(X_j, |X_j - X_{j+1}|) \cap \mathcal{H}^-(\hat{x}_i) \cap L = \{X_{j+1}\}$. It follows that $\hat{X}_{i+1} = X_{j+1}$.

If $\hat{x}_i \geq x_j$, then simple geometric arguments show that necessarily, $\hat{X}_{i+1} = X_j$. \square

Corollary 2.5.2 For all $\epsilon > 0$ and all integers n ,

$$\mathbb{P}(\Delta(X) \geq |X|^{\frac{1}{2}+\epsilon}) = O(|X|^{-n}).$$

Proof. Let $x > 0$ and $\tilde{\pi}_{-e_x}(X)$ be the path from $X = xe_x$ in the directed spanning forest with direction $-e_x$, obtained when using the same point process as in the RST but when removing all points above the line $\overline{0x}$. We define $\tilde{Z}(t)$ from $\tilde{\pi}_{-e_x}(X)$ as we defined $\hat{Y}(t)$ from $\hat{\pi}_0(X)$. From Theorem 2.5.1 we have: $Z(t) \leq \tilde{Z}(t)$.

By symmetry, the law of the process $\tilde{Z}(\cdot)$ is the same as the law of $\hat{Y}(\cdot)$. To derive the result it is enough to prove that:

$$\mathbb{P}\left(\sup_{t \in [-x, x]} \hat{Y}(t) \geq x^{\frac{1}{2}+\epsilon}\right) = O(x^{-n}).$$

We have already proved this statement for the path $\pi_{-e_x}(X)$ in the directed chain built on the whole Poisson point process. The difference between $\pi_{-e_x}(X)$ and $\hat{\pi}_{-e_x}(X)$ appears on the vicinity of the line $\overline{0x}$. Thus the supremum should not be too much affected.

To formalize this idea, consider the event, $\gamma > 0$,

$$A_{\gamma, x} = \{\exists a \in \mathbb{R}^2, \text{ with } |a| \leq 2x \text{ and } |a - \mathcal{A}(a)| \geq x^\gamma\}.$$

Following the proof of Lemma 5.2 of [93], we have

$$\mathbb{P}(A_{\gamma, x}) \leq C_1 \exp(-C_0 x^{2\gamma}).$$

Fix $\epsilon > 0$, $\epsilon'' < \epsilon' < \epsilon$ and $\gamma \leq \frac{1}{2}$. On $A_{\gamma, x}^c$, if $\sup_{t \in [-x, x]} \hat{Y}(t) \geq x^{\frac{1}{2}+\epsilon}$, then for $x = |X|$ large enough, there exists at least a point of $\hat{\pi}(X) \cap N$ with its y -coordinate in the interval $[x^{\frac{1}{2}+\epsilon'}, 2x^{\frac{1}{2}+\epsilon'}]$. Let $X_0 = (x_0, y_0)$ be the rightmost such point. Note that $|x_0| \geq x^{\frac{1}{2}+\epsilon'} \geq \sqrt{x}$. The path $\hat{\pi}_0(X)$ coincides with the path $\pi_0(X_0)$ on the interval $[x^{1/2+\epsilon'}, |x_0|]$ provided the maximal deviation of $\pi_0(X_0)$ (with respect to the line $\overline{0X_0}$) is less than $x^{\frac{1}{2}+\epsilon''}$; indeed the infimum of $\pi_0(X_0)$ will then be lower bounded by $y_0 - x^{\frac{1}{2}+\epsilon''} - x^{\frac{1}{2}+\epsilon''} > 0$ (for x large enough). By Theorem 2.5.1, the event $\{\Delta(\pi_0(X_0)) \geq x^{\frac{1}{2}+\epsilon''}\}$ is a subset of $\tilde{A}_{\epsilon'', x} = \cup_{T \in N \cap B(0, x) \setminus B(0, \sqrt{x})} \{\Delta(|T|, -|T|)(\pi_{-T/|T|}(T)) \geq x^{\frac{1}{2}+\epsilon''}\}$, where $\Delta(y, y')(\pi_{-e_1}(T))$ is the maximal deviation of the path $\pi_{e_1}(T)$ with respect to the straight line with direction e_1 of the path $\pi_{e_1}(T)$ taken between the abscises y and y' . From Theorem 2.4.10 there exists a constant C_1 (depending on ϵ'') such that $\mathbb{P}(\Delta(|T|, -|T|)(\pi_{-T/|T|}(T)) \geq |T|^{\frac{1}{2}+\epsilon''}) \leq C_1 |T|^{-n}$. Now, let $l > e$, we get:

$$\begin{aligned} \mathbb{P}(\tilde{A}_{\epsilon'', x}) &\leq \mathbb{P}(\cup_{T \in N \cap B(0, x) \setminus B(0, \sqrt{x})} \{\Delta(|T|, -|T|)(\pi_{-T/|T|}(T)) \geq |T|^{\frac{1}{2}+\epsilon''}\}) \\ &\leq \mathbb{P}(N(B(0, x)) \geq l\pi x^2) + l\pi x^2 C_1 |x|^{-n/2}. \end{aligned}$$

Thus $\mathbb{P}(\tilde{A}_{\epsilon'', x}) = O(|X|^{-n})$ for all integer n . Using this remark, we have:

$$\mathbb{P}\left(\sup_{t \in [-x, x]} \hat{Y}(t) \geq x^{\frac{1}{2}+\epsilon}\right) \leq \mathbb{P}(A_{\gamma, x}) + \mathbb{P}(\tilde{A}_{\epsilon'', x})$$

□

From Proposition 1.5.2, we deduce Theorem 2.2.1.

2.5.2 Law of Large Numbers on the Radial Path

The aim of this section is to prove Theorem 2.2.4. We use the notation introduced at the beginning of §2.5. Let $X_0 = X, X_1, \dots, X_{H(X)} = 0$ be the successive ancestors of X in the RST.

The edge between X_i and X_{i-1} is $U_i = X_{i-1} - X_i$. Let $U_0 = -X_0$, we have:

$$X_n = -\sum_{l=0}^n U_l \quad \text{and} \quad X_n - X_k = -\sum_{l=k+1}^n U_l.$$

We define $D_0 = B(X_0, |X_0|)$ and

$$D_n = B(X_n, |X_n|) \cap \{\cup_{k=0}^{n-1} B(X_n - X_k, |U_{k+1}|)\}^c. \quad (2.34)$$

The distribution of U_{n+1} given (U_0, \dots, U_n) is:

$$\mathbf{1}(r < |X_n|) \frac{d}{dr} \nu_2(B(0, r) \cap D_n) e^{-\nu_2(B(0, r) \cap D_n)} \frac{\mathbf{1}_{(r, \theta) \in D_n} r dr d\theta}{\nu_1(C(0, r) \cap D_n)} + c \delta_{-X_n}(r, \theta),$$

where c is a normalizing constant.

Let g be a measurable $\mathbb{R}^2 \mapsto \mathbb{R}$ function, we suppose that $|g(X)| \leq \max(C, |X|^\alpha)$ for some positive constants C and α . Without loss of generality we can suppose that g is continuous. A classic limit argument will extend result to any measurable g . We define the statistical average of g on $\pi_0(X)$ as:

$$S_{H(X)} = \sum_{n=1}^{H(X)} g([X_{n-1} - X_n]_{X_{n-1}}).$$

where $[u]_v$ is the vector u rotated by an angle $-\theta$ and $v = r \cos \theta \cdot e_x + r \sin \theta \cdot e_y$ ($[u]_v$ is the vector u expressed in the local coordinates of v).

We will first prove that:

$$\lim_{|X| \rightarrow +\infty} \frac{S_{H(X)}}{H(X)} = \pi(g), \quad (2.35)$$

where π is defined by Equation (2.28).

Results on the matter will follow from the corresponding results on the directed path. We may divide the proof of Theorem 2.2.4 in three steps.

Step I: Regenerative Time

In this part, we prove that the radial navigation is a regenerative navigation:

Lemma 2.5.3 *\mathcal{A} is a regenerative navigation and its associated regenerative time, θ satisfies for some $s > 0$:*

$$\mathbb{E} \exp(s\theta) < +\infty.$$

Proof. As explained in Chapter 1, §1.4.5, this lemma is mainly a consequence of Lemma 2.4.3 which also holds for the RST. An alternative proof of this lemma is given in [18]. This longer proof is based on a coupling due to Athreya and Ney (see [13]). We do not reproduce it here.

□

Step II: Identification of the Limit

Let $V_n = [U_n]_{X_{n-1}}$, θ the regenerative time given by Lemma 2.5.3 and

$$S^\theta(X) = \sum_{n=1}^{\theta} g(V_n).$$

The next step is to identify $\lim_{|X| \rightarrow \infty} \mathbb{E}S^\theta(X)$. As explained in §1.4.5, the stopping time θ is obtained from a coupling with a GI/GI/ ∞ queue. We can also define on the DSF with direction $-e_x = -X/|X|$ the same regenerative time and we introduce:

$$S_{-e_x}^\theta(X) = \sum_{n=1}^{\theta} g(U_{-e_x, n}),$$

where $U_{-e_x, n} = \mathcal{A}_{-e_x}^{n-1}(X) - \mathcal{A}_{-e_x}^n(X)$. The continuity of g and Theorem 2.2.3 imply that $S^\theta(X)$ converges weakly to $S_{-e_x}^\theta(0)$ as $|X|$ tends to infinity. Moreover, by Theorem 2.4.7, $\mathbb{E}S_{-e_x}^\theta(0) = \pi(g)\bar{\theta}$, where $\bar{\theta} = \mathbb{E}\theta$. From Lemma 2.5.3, there exist positive constants C_0, C_1 such that $\mathbb{P}(\theta \geq k) \leq C_1 \exp(-C_0 k)$. Then using the Cauchy-Schwartz inequality, we get

$$\begin{aligned} \mathbb{E}S(X) &= \sum_{k=1}^{\infty} \mathbb{E}(\mathbf{1}(\theta = k)g(V_k(X))) \\ &\leq \sum_{k=1}^{\infty} C_1 \exp(-C_0 k) \sqrt{Eg^2(V_k(X))}. \end{aligned}$$

By Lemma 2.4.3, $g(V_k(X))$ is stochastically dominated by $C_1(1 + Z^\alpha)$, where $\mathbb{P}(Z > t) \leq e^{-\pi t^2/12}$. The set $\{S^\theta(X)\}_{X \in \mathbb{R}^2}$ is thus uniformly integrable, we deduce that a.s.

$$\lim_{|X| \rightarrow +\infty} \mathbb{E}S^\theta(X) = \pi(g)\bar{\theta}. \quad (2.36)$$

Step III: Convergence

The proof is identical to proofs of Lemmas 1.3.15 and 1.4.1. We rewrite them applied to our context. Let \mathcal{F}_n be the σ -algebra generated by (X_0, \dots, X_n) . Lemma 2.5.3 implies the following:

Lemma 2.5.4 *For all x_0 large enough, there exists an increasing sequence of finite stopping times $\{\theta_k\}, k \in \mathbb{N}$, (on an enlarged probability space) such that $\theta_0 = 0$, for all $k \geq 0$ and $n \geq 0$, $\mathbb{P}(\theta_{k+1} - \theta_k > n | \mathcal{F}_{\theta_k}) \leq C_1 \exp(-C_0 n)$, for some positive constants and for $0 \leq k \leq K(X)$ with $K(X) = \sup\{k : |X_{\theta_k}| \geq x_0\}$, $(U_{\theta_{k+1}}, \dots, U_{\theta_{k+1}})$ depends on \mathcal{F}_{θ_k} only through $|X_{\theta_k}|$.*

Lemma 2.5.5 *Almost surely, $H(X)$ and $K(X)$ tend toward infinity as $|X|$ tends to infinity.*

Proof. Let $\beta < 1$ and $A_{\beta, x} = \{\exists a \in N, \text{ with } |a| \leq 2x \text{ and } |a - \mathcal{A}(a)| \geq x^\beta\}$. The proof of Lemma 5.2 of [93] implies that $\mathbb{P}(A_{\beta, x}) = O(|x|^{-q})$ for all q .

On $A_{\beta, |X|}^c$, $H(X) \geq \lfloor |X|^{1-\beta} \rfloor$. Let M be the number of points in N such that $H(X) \leq |X|^{1-\beta}$. From Campbell's Formula: $\mathbb{E}M \leq 2\pi \int_0^\infty \mathbb{P}(A_{\beta, x}) x dx < \infty$. Hence M is finite almost surely.

To prove that $K(X)$ is finite, notice that

$$\mathbb{P}(\theta_{k+1} - \theta_k > n | \mathcal{F}_{\theta_k}) \leq C_1 \exp(-C_0 n)$$

which implies that a.s. $\limsup_k \theta_k/k < C_1 < \infty$. Hence, a.s. for k large enough $|X_{\lfloor C_1 k \rfloor}| \geq x_0$ implies that $K(x) \geq k$. Pick $k = \lfloor |x|^{1-\beta} \rfloor$ and the proof is similar to the proof for $H(X)$. \square We may write:

$$\frac{S_{H(X)}}{H(X)} = \frac{1}{H(X)} \sum_{k=1}^{K(X)} \tilde{S}_k(X) + \frac{1}{H(X)} \sum_{\theta_{K(X)+1}}^{H(X)} g(V_n).$$

There is almost surely a finite number of edges in $B(0, x_0)$; thus, from Lemma 2.5.5, the second term tends a.s. to 0. From Equation (2.36), we also obtain that a.s.

$$\lim_{x \rightarrow \infty} \frac{1}{K(X)} \sum_{k=1}^{K(X)} \mathbb{E}(\tilde{S}_k(X) | \mathcal{F}_{\theta_k}) = \pi(g)\bar{\theta}.$$

Moreover using the same arguments as in Equation (2.36), we get $\mathbb{E}(|\tilde{S}_k(X)|^2) < M < \infty$. We can then apply Theorem VII.9.3 of Feller [62] which gives

$$\lim_{x \rightarrow \infty} \frac{1}{K(X)} \sum_{k=1}^{K(X)} \tilde{S}_k(x) = \lim_{x \rightarrow +\infty} \frac{1}{K(X)} \sum_{k=1}^{K(X)} \mathbb{E}(\tilde{S}_k(x) | \mathcal{F}_{\theta_k}) = \pi(g)\bar{\theta}, \quad a.s.$$

For $g = 1$, we deduce that a.s. $H(X)/K(X)$ tends to $\bar{\theta}$. This ends the proof of Equation (2.35).

The proof of Equation (2.3) is a consequence of Theorem 1.5.2 and Equation (2.35). For all k , a.s. as x tends toward infinity, $[X_{k-1} - X_k]_{X_{k-1}}$ tends toward $X_{k-1} - X_k$. If g is continuous, we deduce that $1/H(xe_x) \sum_{k=1}^{H(xe_x)} g(X_{k-1} - X_k)$ and $1/H(xe_x) \sum_{k=1}^{H(x)} g([X_{k-1} - X_k]_{X_{k-1}})$ have the same limit. If g is not continuous, we conclude by a usual limit argument.

Corollary 2.5.6 *The following a.s. limits hold:*

$$\lim_{|X| \rightarrow +\infty} \frac{H(X)}{|X|} = \frac{1}{p}.$$

$$\lim_{|X| \rightarrow +\infty} \frac{1}{|X|} \sum_{k=0}^{H(X)-1} |X_{k+1} - X_k|^\alpha = \frac{l_\alpha}{p}.$$

where p and l_α are defined in Corollary 2.4.8.

2.5.3 Shape of the RST

Figure 2.11 depicts the sequence $\mathcal{T}(k)$, of subtrees with nodes less than k generations away from the origin.

We define $G_k = |\mathcal{T}_0(k)|$; G_k is the size of the ball of center 0 and radius k for the graph-distance on the RST. Theorem 2.2.2 is a consequence of Lemma 2.5.3 and Corollary 1.6.5. By Corollary 1.6.6 we also have the following:

Proposition 2.5.7 *For all $q < p$, there exists a positive constants C_0, C_1 :*

$$\text{if } |X| < nq \text{ and } n \geq 1, \quad \mathbb{P}(H(X) > n) \leq C_1 e^{-C_0(nq - |X|)}.$$

Similarly for $q > p$:

$$\text{if } |X| > nq \text{ and } n \geq 1, \quad \mathbb{P}(H(X) < n) \leq C_1 e^{-C_0(|X| - nq)}.$$

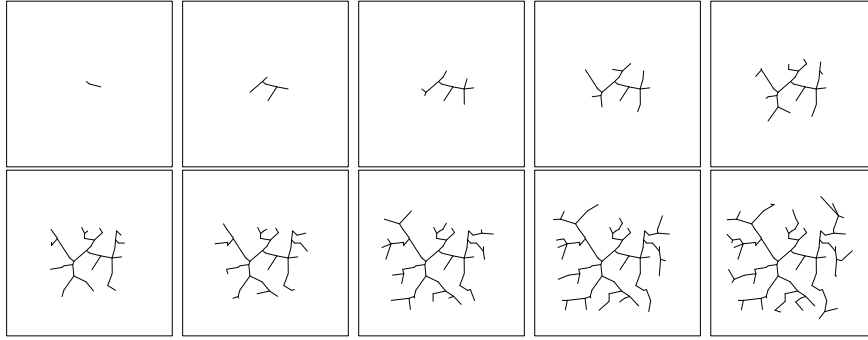

Figure 2.11: The subtrees $\mathcal{T}_0(k)$ for k ranging from 1 to 10.

2.6 Spatial Averages of Edge Lengths

Consider the total edge length of the RST for points included in the ball $B(0, x)$

$$\mathcal{L}_x = \sum_{X \in \mathcal{N}} \mathbf{1}(X \in B(0, x)) |X - \mathcal{A}(X)|.$$

As an example, for the Minimal Spanning Tree, the subadditive ergodic theorem implies that $\frac{\mathcal{L}_x}{x^2}$ tends almost surely toward a constant. We prove that the same result holds for the RST (with of course a larger constant). From Slivnyak-Campbell's Formula

$$\mathbb{E}\mathcal{L}_x = 2\pi \int_0^x \mathbb{E}L(t)tdt.$$

With the change of variable $u = \frac{t}{x}$, this leads to

$$\mathbb{E}\frac{\mathcal{L}_x}{x^2} = 2\pi \int_0^1 u\mathbb{E}L(xu)du,$$

The dominated convergence theorem together with Equation (2.12) gives

$$\lim_{x \rightarrow \infty} \mathbb{E}\frac{\mathcal{L}_x}{x^2} = 2\pi \int_0^1 u \frac{1}{\sqrt{2}} du = \pi/\sqrt{2}.$$

We will prove a stronger result: $\frac{\mathcal{L}_x}{x^2}$ converges almost surely and in L^1 toward $\pi/\sqrt{2}$. To prove this, we consider here a slightly different problem. We sample n points uniformly and independently on the unit disk. This defines a finite point set $F_n = \{0, X_1, \dots, X_n\}$. We can then construct the RST associated to this point set. The total edge length of this RST is

$$\mathcal{L}(F_n) = \sum_{k=1}^n |X_k - \mathcal{A}(X_k)|.$$

First notice that \mathcal{L} is homogeneous of order 1: for all sets F_n as above and all positive real numbers r , we have $\mathcal{L}(rF_n) = r\mathcal{L}(F_n)$, where $rF_n = \{0, rX_1, \dots, rX_n\}$. Using this and the fact that the ratio $N(B(0, x))/x^2$ tends a.s. toward π , it is easy to check that $\frac{\mathcal{L}_x}{x^2}$ converges a.s. toward $\pi/\sqrt{2}$ if and only if $\frac{\mathcal{L}(F_n)}{\sqrt{n}}$ tends to $\sqrt{\frac{\pi}{2}}$. Since we have already computed the mean of $\frac{\mathcal{L}_x}{x^2}$, it is sufficient to prove that $\frac{\mathcal{L}(F_n)}{\sqrt{n}}$ converges a.s. toward a constant.

To prove the last property, we use the smoothness of $\mathcal{L}(F_n)$ (Theorem 2.6.1) and the Rhee and Talagrand concentration inequalities.

Theorem 2.6.1 *There exists a positive constant C_1 such that for all finite subsets F and G as defined above,*

$$|\mathcal{L}(F \cup G) - \mathcal{L}(F)| \leq C_1 \sqrt{|G|},$$

in particular: $\mathcal{L}(F) \leq C_1 \sqrt{|F|}$.

Proof. \mathcal{L} clearly satisfies the subadditive property: for all finite subsets F and G ,

$$\mathcal{L}(F \cup G) \leq \mathcal{L}(G) + \mathcal{L}(F). \quad (2.37)$$

From Lemma 3.4.1 of [145], we deduce that there exists a constant C_1 such that $\mathcal{L}(F) \leq C_1 \sqrt{|F|}$. Subadditivity then implies:

$$\mathcal{L}(F) \geq \mathcal{L}(F \cup G) - \mathcal{L}(G) \geq \mathcal{L}(F \cup G) - C_1 \sqrt{|G|}.$$

It remains to prove that $\mathcal{L}(F) \leq \mathcal{L}(F \cup G) + C_1 \sqrt{|G|}$, for all finite sets F and G as above.

Let $Y \in G$ and suppose that the points X_1, \dots, X_n of F all have Y as ancestor in the RST built over the set $\{0\} \cup F \cup G$. In particular $|X_i| \geq |Y|$. Suppose $|X_k| \geq |X_j|$ then

$$|X_k - Y|^2 \leq |X_k - X_j|^2 = |X_k - Y|^2 + |X_j - Y|^2 - 2|X_k - Y||X_j - Y| \cos \widehat{X_k Y X_j}.$$

Thus if $\widehat{X_k Y X_j} \leq \frac{\pi}{3}$, $|X_k - Y| \leq |X_j - Y|$. The inequality $|X_k - Y|^2 + |X_j - Y|^2 - 2|X_k - Y||X_j - Y| \cos \widehat{X_k Y X_j} \leq |X_j - Y|^2$ holds for $|X_k - Y| \in [0, 2|X_j - Y| \cos \widehat{X_k Y X_j}] \supset [0, |X_j - Y|]$. It follows that:

$$\begin{aligned} |X_k| \geq |X_j| \text{ and } \widehat{X_k Y X_j} \leq \frac{\pi}{3} \\ \text{implies} \\ |X_k - Y| \leq |X_j - Y| \text{ and } |X_k - X_j| \leq |X_j - Y|. \end{aligned} \quad (2.38)$$

Let $\Theta(Y, X)$ denote the oriented angle between $0\vec{Y}$ and $0\vec{X}$. Due to the origin if X is connected to $Y \neq 0$ in the RST then $|\Theta(Y, X)| \leq \pi/2$. We index the n points of F connected to Y by their increasing oriented angle $\Theta(Y, X)$ such that $|\Theta(Y, X_0)|$ is minimal. X_1, \dots, X_d are the points counted clockwise from X_0 : $\Theta(Y, X_0) \leq \Theta(Y, X_1) \leq \dots \leq \Theta(Y, X_d) \leq \pi/2$ and $X_{-1}, \dots, X_{-d'}$ are the points counted counter-clockwise from X_0 with $n = d + d' + 1$ (see right picture in Figure 2.12). We need a tie-breaking rule: if $\Theta(Y, X) = \Theta(Y, X')$ the point with the higher norm has an index closer to 0.

Assume now that for a given $j \geq 0$ we have both $|X_{j+1}| \geq |X_j|$ and $\widehat{X_j Y X_{j+1}} \leq \frac{\pi}{3}$. Then from Equation (2.38): $|X_{j+1} - Y| \leq |X_j - Y|$, X_{j+1} belongs to the set $\mathcal{G}(X_j)$ of points closer to Y than X_j and with a norm larger than X_j . However by elementary considerations $X \in \mathcal{G}(X_j)$ implies that $|\Theta(Y, X)| \leq |\Theta(Y, X_j)|$ (see left picture in Figure 2.12) and this contradicts $\Theta(Y, X_{j+1}) > \Theta(Y, X_j)$ (the strict inequality comes from the tie-breaking rule). Similarly for $j \leq 0$: if $\widehat{X_{j-1} Y X_j} \leq \frac{\pi}{3}$ then $|X_{j-1}| \leq |X_j|$.

There are at most 6 points such that $\widehat{X_i Y X_{i+1}} \geq \frac{\pi}{3}$ ($i \geq 0$) or $\widehat{X_i Y X_{i-1}} \geq \frac{\pi}{3}$ ($i \leq 0$). Therefore from Equation (2.38) there are at most 6 points such that: ($i \geq 0$ and $|X_{i+1}| \leq |X_i|$ and $|X_{i-1} - X_i| \leq |X_i - Y|$) or ($i < 0$ and $|X_{i+1}| \geq |X_i|$ and $|X_{i+1} - X_i| \leq |X_i - Y|$) does not hold.

Let $\mathcal{A}_F(X)$ denote the ancestor of X in the RST built on the set $\{0\} \cup F$. We have

$$\begin{aligned} \mathcal{L}(F) &= \sum_{X \in F} |X - \mathcal{A}_F(X)| \\ &= \sum_{X \in F} \mathbf{1}(\mathcal{A}_F(X) = \mathcal{A}_{F \cup G}(X)) |X - \mathcal{A}_{F \cup G}(X)| + \sum_{Y \in G} \sum_{X \in F \cap \mathcal{A}_{F \cup G}^{-1}(Y)} |X - \mathcal{A}_F(X)| \\ &\leq \mathcal{L}(F \cup G) + \sum_{Y \in G} \sum_{X \in F \cap \mathcal{A}_{F \cup G}^{-1}(Y)} |X - \mathcal{A}_F(X)| - |X - Y|. \end{aligned}$$

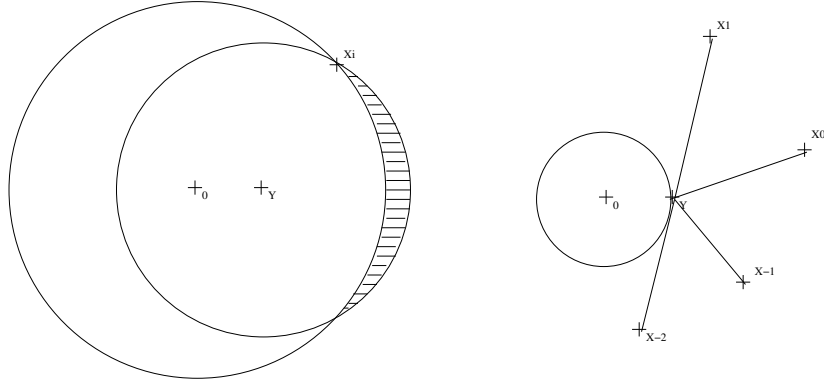

Figure 2.12: On the left, the dashed area is $\mathcal{G}(X_i)$, on the right, the set of connected points to Y .

If $F \cap \mathcal{A}_{F \cup G}^{-1}(Y) = \{X_{-d'}, \dots, X_0, \dots, X_d\}$, for at most 6 points, $|X_i - \mathcal{A}_{F \cup G}(X_i)| = |X_i - Y| \geq |X_i - X_{i-1}| \geq |X_{i-1} - \mathcal{A}_F(X_{i-1})|$ ($i > 0$) or $|X_i - Y| \geq |X_{i+1} - X_i| \geq |X_{i+1} - \mathcal{A}_F(X_{i+1})|$ ($i < 0$) does not hold.

Henceforth, if J denotes the set of points such that the preceding inequality does not hold and $H(Y) = \{X_d, X_{-d'}\} \cup J$, we have $|H(Y)| \leq 8$ and

$$\begin{aligned} \sum_{X \in F \cap \mathcal{A}_{F \cup G}^{-1}(Y) \setminus H(Y)} |X - \mathcal{A}_F(X)| &\leq \sum_{i=1}^d |X_i - X_{i-1}| \\ &\quad + \sum_{i=2}^{d'} |X_{-i} - X_{-i+1}| \\ &\leq \sum_{X \in F \cap \mathcal{A}_{F \cup G}^{-1}(Y)} |X - \mathcal{A}_{F \cup G}(X)|. \end{aligned}$$

If $H = \cup_{Y \in G} H(Y)$, we have $|H| \leq 8|G|$. Using subadditivity, we deduce

$$\mathcal{L}(F) \leq \mathcal{L}(F \cup G) + \mathcal{L}(H) \leq \mathcal{L}(F \cup G) + C\sqrt{8|G|}.$$

□

Theorem 2.6.1 ensures that we can apply a concentration inequality to the functional \mathcal{L} (Theorem 1 of Rhee [138] and Theorem 11.3.2 of Talagrand [150]): $\frac{\mathcal{L}(F_N)}{\sqrt{N}}$ converges a.s. toward its mean. Finally, we have proved that a.s. and in L^1 ,

$$\lim_{x \rightarrow \infty} \frac{\mathcal{L}_x}{x^2} = \pi/\sqrt{2}. \quad (2.39)$$

More generally, for $\alpha \geq 1$, we define

$$\mathcal{L}^{(\alpha)}(F) = \sum_{X \in F} |X - \mathcal{A}(X)|^\alpha.$$

The proof of Theorem 2.6.1 is unchanged if we replace $\mathcal{L}^{(\alpha)}$ by \mathcal{L} (however the constant C_1 does depend on α). Define

$$\lambda_\alpha = \alpha \int_0^\infty r^{\alpha-1} e^{-\frac{\pi r^2}{2}} dr = \mathbb{E}|\mathcal{A}_{-e_x}(0)|^\alpha. \quad (2.40)$$

From Equation (2.11), using Campbell formula, we get that

$$\lim_{x \rightarrow +\infty} \mathbb{E} \mathcal{L}^{(\alpha)}(x)/x^2 = \pi \lambda_\alpha.$$

We finally deduce:

Theorem 2.6.2 *For all $\alpha \geq 1$ a.s. and in L^1 ,*

$$\lim_{x \rightarrow \infty} \frac{\mathcal{L}_x^{(\alpha)}}{x^2} = \pi \lambda_\alpha.$$

We can rewrite this result as $1/N(B(0, x)) \sum_{X \in N} |X - \mathcal{A}(X)|^\alpha$ tends a.s. toward λ_α . That is, the spatial average of the lengths of the edges tends toward the distribution of the length of $(0, \mathcal{A}_d(0))$ in the DSF.

It is crucial to notice that $\lambda_\alpha < l_\alpha$: the spatial average and the average along a long path do not coincide.

Remark 2.6.3 We have done our analysis on the length of an edge, of course the same type of result could be obtained for other stabilizing functional. So in order to derive weak laws for stabilizing functionals, we can invoke Theorem 2.1 of [133].

2.7 Model Extension and Open Problems

2.7.1 Greedy Forests

The radial spanning tree lies in a large class of spanning forests which are locally defined. We could extend the definition of the radial spanning tree over a point set N as follows.

Let l be a measurable function from N to \mathbb{R} and L be a measurable function from $N \times N$ to $\overline{\mathbb{R}}$. Suppose that for all $X, Y, Z, T \in N$, $\{X, Y\} \neq \{Z, T\}$, $L(X, Y) \neq L(Z, T)$, for $x \neq y$ $l(X) \neq l(Y)$ and $l(N)$ has no accumulation point. Then we can define the following forest $\mathcal{F} = (N, E)$: for $l(Y) < l(X)$: $(X, Y) \in E$ if and only if $Y = \arg \min_{Z \in N, l(Z) < l(X)} L(X, Z)$.

When $l(X) = |X|$, $L(X, Y) = |X - Y|$, we define the radial spanning tree, if $l(X) = \langle X, e_x \rangle$ and $L(X, Y) = |X - Y|$, this is the directed spanning forest. If $L(X, Y)$ is the length of well chosen cylinder, we obtain the Poisson Forest of [64].

2.7.2 The Radial Spanning Tree of a Voronoi Cell

An interesting way to extend the RST is to consider two independent Poisson point processes, $N_0 = \{X_n^0\}$, the point process of *cluster heads* (we use here the terminology of sensor networks, which motivate this extension), of intensity λ_0 and $N_1 = \{X_n^1\}$, the point process of *nodes*, with intensity λ_1 . The first point process tessellates the plane in Voronoi cells. We denote by V_n the Voronoi cell of point X_n^0 w.r.t. the points of N_0 . Two forests can then be defined in relation with this tessellation:

- The family of *internal* RSTs: the n -th tree of this forests, \mathcal{T}_n , is the RST built using the points of N_1 that are contained in V_n , with X_n^0 as a root.
- The family of *local* RSTs: if node X belongs to V_n , one defines its ancestor as the point of $(N_1 \cup \{X_n^0\}) \cap B(X_n^0, |X - X_n^0|)$ that is the closest to X . Notice that this ancestor does not necessarily belong to V_n . Nevertheless, this rule defines a forest too (see Lemma 2.7.1). One then defines the n -th local RST tree \mathcal{U}_n as the tree which is the union of all the paths from nodes with ultimate ancestor X_n^0 .

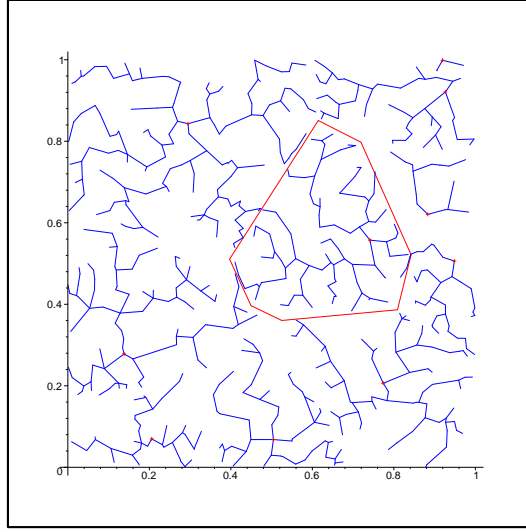

Figure 2.13: Local Voronoi radial spanning trees (in blue) of 600 nodes uniformly and independently distributed in the unit square, w.r.t 10 cluster heads (in red), also uniformly and independently distributed in the unit square. The Voronoi cell of one of the cluster heads is depicted in red.

In what follows, we concentrate on the second case which can be analyzed using the same type of tools as in §2.3. Figure 2.13 depicts a sample of such a forest.

Lemma 2.7.1 *Almost surely, there exists no node X of N_0 such that the sequence of ancestors of X based on the local RST rule contains node X .*

Proof. Let $\{Y_i\}_{i \geq 0}$ be the sequence of ancestors of $X = Y_0$. If $Y_i = X$ for some $i > 0$, then necessarily the points of $\{Y_i\}$ belong to different Voronoi cells (if this were not the case, then the distance to the cluster head of the cell to which all points belong would be strictly decreasing, which forbids cycles). Then one can then rewrite $\{Y_i\}_{i \geq 0}$ as

$$\{Y_i\}_{i \geq 0} = \{Z_0(1), \dots, Z_0(n_0), Z_1(1), \dots, Z_1(n_1), \dots, Z_j(1), \dots, Z_j(k), \dots\}$$

with $Z_l(1), \dots, Z_l(n_l) \in W_l$ for all $0 \leq l \leq j$, where $\{W_j\}_{j \geq 0}$ is a sequence of cells such that $W_l \neq W_{l+1}$ for all $l < j$, n_l is a sequence of integers and $Z_j(k) = X$. Let S_l denote the cluster head of W_l . Then the definition of the local RST implies that a.s.

$$|X - S_0| = |Z_0(1) - S_0| > |Z_0(2) - S_0| > \dots > |Z_0(n_0) - S_0| > |Z_1(1) - S_0|.$$

Since $Z_1(1)$ belongs to W_1 , we have a.s.

$$|Z_1(1) - S_0| > |Z_1(1) - S_1|.$$

For the same reasons, for all $l = 1, \dots, j - 1$

$$|Z_l(1) - S_l| > |Z_l(2) - S_l| > \dots > |Z_l(n_l) - S_l| > |Z_{l+1}(1) - S_l|$$

and

$$|Z_{l+1}(1) - S_l| > |Z_{l+1}(1) - S_{l+1}|, \quad a.s.$$

In addition

$$|Z_j(1) - S_j| > |Z_l(2) - S_l| > \cdots > |Z_j(k) - S_j| = |X - S_0|.$$

Hence a contradiction. \square

Let \mathcal{L}_n denote the total length of all edges from nodes in V_n . Let E_0 denote the Palm probability w.r.t. N_0 . We have

$$\mathcal{L}_n = \sum_m \mathbf{1}(X_m^1 \in V_n) L_m,$$

where L_m is the length of the link that connects X_m^1 to its ancestor. Using the fact that $X_m^1 \in V_n$ iff $N_0(B(X_m^1, |X_m^1 - X_n^0|)) = 0$ and the fact that $L_m > u$ with $u < |X_m^1 - X_n^0|$ iff $N_1(B(X_m^1, u) \cap B(X_n^0, |X_m^1 - X_n^0|)) = 0$, we get from Campbell's formula that

$$E_0 \left(\sum_m \mathbf{1}(X_m^1 \in V_n) L_m \right) = 2\pi\lambda_1 \int_{r=0}^{\infty} e^{-\lambda_0\pi r^2} \left(\int_{u=0}^r e^{-\lambda_1 M(r,u)} du \right) r dr,$$

with $M(r, u)$ the lune defined in §2.3.1. Hence

$$E_0(\mathcal{L}_0) = 2\pi\lambda_1 \int_{r=0}^{\infty} e^{-\lambda_0\pi r^2} \left(\int_{u=0}^r e^{-\lambda_1 M(r,u)} du \right) r dr. \quad (2.41)$$

2.7.3 Some open problems

The local geometry of the RST is rather well understood. Unfortunately, the distribution of the degree of a vertex is still unknown. We have computed only its mean. It would be appealing to compute this distribution at least in the DSF. In contrast with what happens in the Minimal Spanning Tree, the degree is not upper bounded and so the moments of this distribution could be large.

Properly scaled, the path $\pi(X)$ of successive ancestors of X in the DSF, converges weakly toward the Brownian Motion. An interesting problem is to find a functional central limit theorem for $\pi_0(X)$. Along this line, we may prove that the DSF converges weakly toward the Brownian Web. Proving a weak limit for the RST is a challenging question.

Chapter 3

Minimal spanning tree and Scaling Relations for percolation

Résumé Nous nous intéressons au poids maximal des arêtes du chemin reliant deux sommets de l'arbre couvrant minimal. Nous proposons une preuve d'un Ansatz de Aldous relié à l'existence d'une densité pour cette variable aléatoire. Enfin, nous élargissons la méthode proposée en esquissant des connections entre certaines propriétés de l'arbre couvrant minimal et les relations d'échelle en percolation.

Abstract We consider the maximal weight of the edges on the path between two vertices in the minimal spanning tree. We propose a proof for an Ansatz of Aldous related to the existence of a density for this random variable. Finally, we enlarge our picture and sketch some relations between some properties of the minimal spanning tree and the scaling relations in percolation.

3.1 Introduction

The minimal spanning tree (MST) is one of the most studied structures in combinatorial optimization, see the monographs of Steele [145], Yukich [161] or Penrose [129] for an overview of the known properties of the Euclidean MST. There are however few known results on the geometric properties of the paths between two vertices in this tree. In this chapter, we examine some properties of these paths and relate them with scaling exponents in percolation. This work has not reached a satisfactory stage yet. It is however interesting to present it in this thesis. In particular, it appears clearly that the mathematical tools involved in the analysis of the paths in the MST differs significantly from the paths in the regenerative navigation trees.

We first define the euclidean minimal spanning tree on a non-equidistant and locally finite point set of \mathbb{R}^d . A point set $\{\eta_i\}_i$ is non-equidistant if the interpoint distances $(|\eta_i - \eta_j|, i < j)$ are all distinct, where $|\cdot|$ is the euclidean norm. With a slight abuse of notation, a locally finite point set Φ will also be represented as a counting measure: $\Phi = \sum_i \delta_{\eta_i}$. Let Φ be a non-equidistant and locally finite point set of \mathbb{R}^d , and $G_t(\Phi)$ be the subgraph consisting of those edges $e = (v, w)$ with $v, w \in \Phi$ and $|v - w| < t$. The minimal spanning forest (MSF) is a spanning forest on Φ defined by

$$e = (v, w) \in MSF(\Phi) \text{ if the connected components containing } v \text{ and } w \text{ in } G_{|v-w|}(\Phi) \text{ are disjoint and not both infinite.}$$

This definition is consistent: on a finite point set, the MSF is the spanning tree which minimizes the total edge length. If Φ is a Poisson point process, $G_{|v-w|}(\Phi)$ has at most one infinite connected component. In dimension 2, it can be shown that the MSF is indeed a tree (see Alexander [7]).

From now on, we consider a Poisson point process $\Phi = \sum_i \delta_{\eta_i}$ of rate 1 in \mathbb{R}^2 . Let $\Phi^O = \delta_O + \Phi$, by Slynjack Theorem, Φ^O is a Poisson point process in its Palm version at O . Let $G_t(\Phi^O)$ be the subgraph consisting of those edges $e = (v, w)$ with $v, w \in \Phi^O$ and $|v - w| < t$. G_t is a continuum percolation graph with deterministic radius t (refer to Meester and Roy [121]), we will denote by r_c the critical range at which an infinite connected component appears. For an edge $e = (v, w)$, we define:

$$\begin{aligned} l(e) &= |v - w| \\ perc(e) &= \inf\{t : v \text{ and } w \text{ in the same component of } G_t\} \\ perc^*(e) &= \inf\{t : v \text{ and } w \text{ in the same component of } G_t \setminus \{e\}\} \\ \delta(e) &= l(e) - perc(e) \geq 0. \end{aligned}$$

We define a function μ on \mathbb{R}_+ by

$$\mu(x) = \mathbb{E} \sum_i \mathbf{1}(0 < \delta(O, \eta_i) < x).$$

Ansatz 7 in Aldous [4] reads:

Ansatz 3.1.1

$$\limsup_{x \downarrow 0} \frac{\mu(0, x)}{x} < \infty.$$

The Ansatz is stated for continuum percolation. As it is pointed in [4], due to the independence of edges, the analog of this Ansatz for discrete percolation is straightforward. In this note, we present an alternative proof of the Ansatz in two dimensions which relies on the scaling relations of percolation near the critical range. The scaling relations are supposed to

follow a universality principle: they depend on the dimension and not on the neighboring graph. Therefore our proof is general and it does not use any particular feature of discrete percolation.

Properly speaking, in Kesten [103], the scaling relations in 2D percolation have been rigorously proved for a large class of discrete graphs. Undoubtedly, the scaling relations are also satisfied for continuum percolation with deterministic radius. A proof of this fact should not be hard to obtain.

Scaling relations do also exist in higher dimension. Rigorous proofs of these relations is an active research field.

In this chapter, in Section 3.2, we first present the main steps of the proof of the Ansatz. In Section 3.3 and Section 3.4, we prove some technical results in continuum percolation. Finally in Section 3.5, we add a comment on the connections between minimal spanning tree and critical exponents.

3.2 Main steps of the proof

We need to introduce some continuum percolation terminology: for any r and λ , we define the probability measure $\mathbb{P}_{\lambda,r}^{O,\underline{t}}$ under which Φ is a Poisson point process of intensity λ and an edge e from the complete graph $\Phi^{O,\underline{t}}$ is said to be open (resp. closed) if $\ell(e) < r$ (resp. $\ell(e) \geq r$). We denote by G^O the open cluster containing the origin : $G^O = G_r^O$. Let $r_c(\lambda) = r_c/\sqrt{\lambda}$ be the critical radius for the Poisson continuum percolation model of density λ and deterministic radius, i.e. for $r < r_c(\lambda)$ the number of vertices in any open cluster is finite whereas for $r > r_c(\lambda)$ there exists an unique unbounded open cluster.

We give now the main steps of the proof of the Ansatz, the technical proofs are given in the next sections. Throughout this chapter, we denote by $C, C_1, C_2 \dots$ positive constants not depending on the parameter of the problem.

Lemma 3.2.1 *For any $\epsilon > 0$, we have*

$$\begin{aligned} \text{for } 0 < t < r_c - \epsilon, & \quad \mathbb{P}^{O,\underline{t}}(\text{perc}(O, \underline{t}) \in [t - x, t]) \leq C_1 x, \\ \text{for } t > r_c - \epsilon, & \quad \mathbb{P}^{O,\underline{t}}(\text{perc}(O, \underline{t}) \in [t - x, t]) \leq C_1 x e^{-C_2 t}, \end{aligned}$$

We now concentrate on the case $t \in (r_c - \epsilon, r_c + \epsilon)$. Under $\mathbb{P}_{\lambda,r}^{O,\underline{t}}$, we define the event

$$A = \{\underline{t} \in G^O\}.$$

We have

$$\mathbb{P}^{O,\underline{t}}(\text{perc}(O, \underline{t}) \in [t - x, t]) = \mathbb{P}_{1,t}^{O,\underline{t}}(A) - \mathbb{P}_{1,t-x}^{O,\underline{t}}(A). \quad (3.1)$$

Using coupling and scaling properties of the Poisson point process, we can translate variations in the radius of the Boolean model to variations in the intensity of the model (our main motivation being to use a continuous analog of Russo's Formula). More precisely, the transformation on \mathbb{R}^2 : $X \mapsto \sigma X$ maps a Poisson point process of intensity λ into a Poisson point process of intensity $\lambda\sigma^{-2}$. We deduce that:

$$\mathbb{P}_{\lambda,r}^{O,\underline{t}}(A) = \mathbb{P}_{\lambda\sigma^{-2},r\sigma}^{O,\sigma\underline{t}}(A).$$

Applying these relations, with $\sigma = t/(t - x)$ in (3.1), we obtain

$$\begin{aligned} \mathbb{P}^{O,\underline{t}}(\text{perc}(O, \underline{t}) \in [t - x, t]) &= \mathbb{P}_{1,t}^{O,\underline{t}}(A) - \mathbb{P}_{\sigma^{-2},t}^{O,\underline{t}}(A) \\ &\quad + \mathbb{P}_{\sigma^{-2},t}^{O,\underline{t}}(A) - \mathbb{P}_{\sigma^{-2},t}^{O,\sigma\underline{t}}(A). \end{aligned} \quad (3.2)$$

We show in Section 3.3.2 that the second difference is bounded by:

$$\left| \mathbb{P}_{\sigma^{-2}, t}^{O, \underline{t}}(A) - \mathbb{P}_{\sigma^{-2}, t}^{O, \sigma \underline{t}}(A) \right| \leq Ct^2x, \quad (3.3)$$

For the first difference, we need the next lemma which is a consequence of Theorem 2.1 in Zuyev [165]. This is a continuous analog of Russo's Formula.

Lemma 3.2.2 *For all $\lambda > 0$ and all positive $t \neq r_c(\lambda)$:*

$$\frac{\partial}{\partial \lambda} \mathbb{P}_{\lambda, t}^{O, \underline{t}}(A) = \mathbb{E}_{\lambda, t}^{O, \underline{t}} \nu(\mathcal{P}),$$

where,

$$\mathcal{P} = \{X \in \mathbb{R}^2 : \mathbf{1}(\underline{t} \in G_t^O(\Phi^{O, \underline{t}, X})) \neq \mathbf{1}(\underline{t} \in G_t^O(\Phi^{O, \underline{t}}))\}$$

and ν denote the Lebesgue measure on \mathbb{R}^2 . A point X in \mathcal{P} is a pivotal point for the event A .

Hence we have as x tends to 0 (recall that $\sigma = t/(t-x)$),

$$\begin{aligned} \mathbb{P}_{1, t}^{O, \underline{t}}(A) - \mathbb{P}_{\sigma^{-2}, t}^{O, \underline{t}}(A) &\leq (1 - \sigma^{-2}) \sup_{\lambda \in [\sigma^{-2}, 1]} \frac{\partial}{\partial \lambda} \mathbb{P}_{\lambda, t}^{O, \underline{t}}(A) \\ &\sim \frac{2x}{t} \sup_{\lambda \in [\sigma^{-2}, 1]} \mathbb{E}_{\lambda, t}^{O, \underline{t}} \nu(\mathcal{P}) \end{aligned}$$

The difficulty of Ansatz 3.1.1 is on the bound of $t \mapsto \mathbb{E}_t \nu(\mathcal{P})$ in the neighborhood of r_c . The following Lemma will imply the Ansatz.

Lemma 3.2.3 *There exist $C > 0$ and $\eta > 0$ such that for all $t \in (r_c - \epsilon, r_c + \epsilon)$ and all λ in a neighborhood of 1,*

$$\mathbb{E}_{\lambda, t}^{O, \underline{t}} \nu(\mathcal{P}) \leq C \left| t - \frac{r_c}{\sqrt{\lambda}} \right|^{-1+\eta}.$$

The proof of Lemma 3.2.3 is postponed to Appendix. It relies on the scaling relations in 2D-percolation. The scalar η can be related to a critical exponent of 2D-percolation.

We now show how Lemma 3.2.3 implies that

$$\int_{r_c - \epsilon}^{r_c + \epsilon} \mathbb{P}^{O, \underline{t}}(\text{perc}(O, \underline{t}) \in [t-x, t]) dt \leq Cx. \quad (3.4)$$

Indeed, by Equations (3.2) and (3.3), it is sufficient to bound:

$$\frac{\mathbb{P}_{1, t}^{O, \underline{t}}(A) - \mathbb{P}_{\sigma^{-2}, t}^{O, \underline{t}}(A)}{x} = \frac{2}{t} \mathbb{E}_{\lambda(x, t), t}^{O, \underline{t}} \nu(\mathcal{P}),$$

where $\lambda(x, t) \in ((1-x/t)^2, 1)$ and $\sigma = \frac{t}{t-x}$. First for $t \in (r_c - \epsilon, r_c)$, we have by Lemma 3.2.3,

$$\int_{r_c - \epsilon}^{r_c} \frac{\mathbb{P}_{1, t}^{O, \underline{t}}(A) - \mathbb{P}_{\sigma^{-2}, t}^{O, \underline{t}}(A)}{x} dt \leq \int_{r_c - \epsilon}^{r_c} |t - r_c|^{-1+\eta} dt < +\infty.$$

We now consider the case $t \in (r_c, r_c + \epsilon)$. First note that for any $C > 0$,

$$\int_{r_c}^{r_c(1+Cx)} \frac{\mathbb{P}_{1, t}^{O, \underline{t}}(A) - \mathbb{P}_{\sigma^{-2}, t}^{O, \underline{t}}(A)}{x} t dt \leq r_c^2 (C + Cx/2).$$

Take $C > 0$ such that for all $t \in [r_c(1+Cx), r_c+\epsilon]$ and x small enough, we have $r_c/\sqrt{\lambda(x,t)} \leq r_c(1+Cx)$. This is possible since $\lambda(x,t) \geq 1 - (2+x/t)x/t$, and in this case, we have,

$$|t - r_c/\sqrt{\lambda(x,t)}|^{-1+\eta} \leq |t - r_c(1+Cx)|^{-1+\eta}.$$

Hence, we obtain

$$\int_{r_c(1+Cx)}^{r_c+\epsilon} \frac{\mathbb{P}_{1,t}^{O,\underline{t}}(A) - \mathbb{P}_{\sigma^{-2},t}^{O,\underline{t}}(A)}{x} dt \leq C_1.$$

Ansatz 3.1.1 follows from Lemma 3.2.1 and Equation (3.4).

3.3 Continuum percolation far from critical radius

We first introduce some notations. For a set $S \subset \mathbb{R}^2$, we denote by $d(S) = \sup\{|x-y|, x, y \in S\}$ its diameter. For $x \in \mathbb{R}^2$ and $r > 0$, $B(x, r)$ denotes the open ball of radius r centered at x . For $n \in \mathbb{N}$ we denote $S(n) = [-n, n]^2$. For $x \in \mathbb{R}^2$ and $S \subset \mathbb{R}^2$, we define $\text{dist}(x, S) = \inf\{|x-y|, y \in S\}$.

Under the probability measure $\mathbb{P}_{\lambda,r}^{O,\underline{t}}$, the occupied region is $\cup_{X \in \Phi^{O,\underline{t}}} B(X, r/2)$ and the vacant region is the complement of the occupied region. The occupied component of the origin W is defined by $\mathbb{P}_{\lambda,r}^{O,\underline{t}}(W = \cup_{X \in G^O} B(X, r/2)) = 1$. The vacant component containing the point $\underline{t}/2$ is denoted by V . More generally, for $r > 0$ the occupied region at level r is $\cup_{X \in \Phi^{O,\underline{t}}} B(X, r/2)$ and we denote $W_r = \cup_{X \in G_r^O} B(X, r/2)$ the occupied component of the origin at level r and V_r the vacant component containing the point $\underline{t}/2$ at level r .

3.3.1 Proof of Lemma 3.2.1

Since we may assume that all interdistances are different, there exists a unique $(X, Y) \in (\Phi^{O,\underline{t}})^2$ such that $\text{perc}(O, \underline{t}) = |X - Y|$, indeed (X, Y) is the edge of the MST on the path from the origin to \underline{t} with maximal length.

First consider the case $t < r_c - \epsilon$. Let $S_z = z\underline{t}/2 + S(t/2)$ where $z \in \mathbb{Z}^2$. If the event $\{\text{perc}(O, \underline{t}) \in [t-x, t]\}$ occurs, there is some $z \in \mathbb{Z}^2$ such that $W \cap S_z \neq \emptyset$ and there exists $X, Y \in \Phi \cap S_z$ such that $|X - Y| \in [t-x, t)$. Note that we have for any $z \in \mathbb{Z}^2$,

$$\mathbb{P}_{1,t}^{O,\underline{t}}(\exists X, Y \in \Phi \cap S_z, |X - Y| \in [t-x, t)) = C(1+t^3)x.$$

Hence we have

$$\begin{aligned} & \mathbb{P}^{O,\underline{t}}(\text{perc}(O, \underline{t}) \in [t-x, t)) \\ & \leq \sum_{z \in \mathbb{Z}^2} \mathbb{P}_{1,t}^{O,\underline{t}}(W \cap S_z \neq \emptyset, \exists X, Y \in \Phi(S_z), |X - Y| \in [t-x, t)) \\ & \leq \left(5 + \sum_{z, \|z\| \geq 2} \mathbb{P}_{1,t}^{O,\underline{t}}(W \cap S_z \neq \emptyset) \right) C(1+t^3)x, \end{aligned} \tag{3.5}$$

where we denote $\|z\| = \max(z_1, z_2)$. Lemma 3.3 of [121] ensures that the sum of (5.13) is finite for $t < r_c - \epsilon$.

The case $t > r_c + \epsilon$ is quite similar. If the event $\{\text{perc}(O, \underline{t}) \in [t-x, t)\}$ occurs, there is some $z \in \mathbb{Z}^2$ such that $V_{t-x} \cap S_z \neq \emptyset$ and there exists $X, Y \in \Phi \cap S_z$ such that $|X - Y| \in [t-x, t)$.

Hence we have

$$\begin{aligned} \mathbb{P}^{O,\underline{t}}(\text{perc}(O, \underline{t}) \in [t-x, t]) &\leq \left(5 + \sum_{z, \|z-\underline{t}/2\| \geq 2} \mathbb{P}_{1,t}^{O,\underline{t}}(V_{t-x} \cap S_z \neq \emptyset) \right) C(1+t^3)x \\ &\leq C_1 e^{-C_2 t} x, \end{aligned} \quad (3.6)$$

where (3.6) follows from Lemma 4.1 of [121] and the fact that

$$\mathbb{P}_{1,t}^{O,\underline{t}}(V_{t-x} \cap S_z \neq \emptyset) \leq \mathbb{P}_{1,t}^{O,\underline{t}}(d(V_{t-x}) > \|z - \underline{t}/2\|).$$

3.3.2 Proof of (3.3)

To bound the second difference, note that

$$\begin{aligned} \mathbb{P}_{\sigma^{-2},t}^{O,\underline{t}}(A) &= \mathbb{P}_{\sigma^{-2},t}^O(B(\underline{t}, t) \cap G^O \neq \emptyset) \\ \mathbb{P}_{\sigma^{-2},t}^{O,\sigma\underline{t}}(A) &= \mathbb{P}_{\sigma^{-2},t}^O(B(\sigma\underline{t}, t) \cap G^O \neq \emptyset), \end{aligned}$$

where $B(X, r)$ denotes the open ball of radius $r > 0$ centered at $X \in \mathbb{R}^2$. Hence we have

$$\left| \mathbb{P}_{\sigma^{-2},t}^{O,\underline{t}}(A) - \mathbb{P}_{\sigma^{-2},t}^{O,\sigma\underline{t}}(A) \right| \leq \mathbb{P}(\Phi(B(\underline{t}, t) \Delta B(\sigma\underline{t}, t)) \geq 1) \leq Ct^2 x,$$

where $B(\underline{t}, t) \Delta B(\sigma\underline{t}, t) = B(\underline{t}, t) \setminus B(\sigma\underline{t}, t) \cup B(\sigma\underline{t}, t) \setminus B(\underline{t}, t)$ denotes the symmetric difference. This is exactly (3.3).

3.3.3 Proof of Lemma 3.2.2

Our Lemma 3.2.2 is a slight extension of Theorem 2.1 of Zuyev [165] (to non-compact set). First note that for any $X \in \mathcal{P}$, we have $\Phi(B(X, t/2) \cap \mathcal{P}) \leq 2$, so that there exists a constant $C_t > 0$ depending on t such that,

$$\Phi(\mathcal{P}) \leq C_t \nu(\mathcal{P}).$$

For $n \in \mathbb{N}$ we define $S(n) = [-n, n]^2$ and $A(n) = \{\underline{t} \in G^O(\Phi \cap S(n))\}$, where $G^O(\Phi \cap S(n))$ is the connected component of $G^O \cap S(n)$ containing the origin. We have clearly $A(n) \subset A(n+1)$ and $A = \cup_n A(n)$, thus we have

$$\mathbb{P}_{\lambda,t}^{O,\underline{t}}(A) = \sum_{n \geq 0} \left(\mathbb{P}_{\lambda,t}^{O,\underline{t}}(A(n+1)) - \mathbb{P}_{\lambda,t}^{O,\underline{t}}(A(n)) \right).$$

Since $A(n)$ depends on the Poisson point process in the compact set $S(n)$, we can apply Theorem 2.1 of [165]. Suppose that the event $A(n)$ occurs, then the pivotal points are the point of Φ that are in the intersection of all paths from O to \underline{t} in $G_t^O(\Phi \cap S(n))$. Clearly the critical and boundary sets for the event $A(n)$ are empty. Hence we have

$$\frac{\partial}{\partial \lambda} \mathbb{P}_{\lambda,t}^{O,\underline{t}}(A(n)) = \frac{1}{\lambda} \mathbb{E}_{\lambda,t}^{O,\underline{t}}(\Phi(\mathcal{P}_n)),$$

with

$$\mathcal{P}_n = \{X \in \mathbb{R}^2 : \mathbf{1}\{\underline{t} \in G_t^O(\Phi^{O,\underline{t},X} \cap S(n))\} \neq \mathbf{1}\{\underline{t} \in G_t^O(\Phi^{O,\underline{t}} \cap S(n))\}\}.$$

Consider first the case $t < r_c(\lambda)$. Note that for all n , we have $\mathcal{P}_n \subset W$ (where W is the occupied component of the origin) and for $n > d(W)$ (the diameter of W), we have $\mathcal{P}_n = \mathcal{P} \subset W$, hence $\Phi(\mathcal{P}_n) \leq C_t \nu(W)$ and then

$$\left| \frac{\partial}{\partial \lambda} \mathbb{P}_{\lambda,t}^{O,\underline{t}}(A(n+1)) - \frac{\partial}{\partial \lambda} \mathbb{P}_{\lambda,t}^{O,\underline{t}}(A(n)) \right| \leq \frac{C_t}{\lambda} \mathbb{E}_{\lambda,t}^{O,\underline{t}}[\nu(W) \mathbf{1}\{n \leq d(W)\}].$$

Summing over n , we have

$$\sum_{n \geq 0} \mathbb{E}_{\lambda, t}^{O, \underline{t}}[\nu(W) \mathbf{1}\{n \leq d(W)\}] = \mathbb{E}_{\lambda, t}^{O, \underline{t}}[d(W)\nu(W)] \leq \pi \mathbb{E}_{\lambda, t}^{O, \underline{t}}[d(W)^3] < \infty,$$

and the fact that the expectation is finite follows from Lemma 3.3 of [121].

From the dominated convergence theorem, we have

$$\begin{aligned} \frac{\partial}{\partial \lambda} \mathbb{P}_{\lambda, t}^{O, \underline{t}}(A) &= \sum_{n \geq 0} \frac{\partial}{\partial \lambda} \left(\mathbb{P}_{\lambda, t}^{O, \underline{t}}(A(n+1)) - \mathbb{P}_{\lambda, t}^{O, \underline{t}}(A(n)) \right) \\ &= \frac{1}{\lambda} \mathbb{E}_{\lambda, t}^{O, \underline{t}} \left[\sum_n \Phi(\mathcal{P}_{n+1}) - \Phi(\mathcal{P}_n) \right] \\ &= \frac{1}{\lambda} \mathbb{E}_{\lambda, t}^{O, \underline{t}}[\Phi(\mathcal{P})] = \mathbb{E}_{\lambda, t}^{O, \underline{t}}\nu(\mathcal{P}), \end{aligned}$$

where the last equality follows from Campbell formula for Poisson point processes.

The argument is quite similar for the case $t > r_c(\lambda)$. Recall that V is the vacant component containing the point $\underline{t}/2$. If $V = \emptyset$, we have $\Phi(\mathcal{P}) \leq 3$ because there exists a point η of Φ at distance less than $t/2$ from $\underline{t}/2$ and then $\mathcal{P} \subset \{O, \underline{t}, \eta\}$. Assume now that $V \neq \emptyset$. Then for any $\eta \in \Phi \cap \mathcal{P}$, we have $\text{dist}(\eta, V) \leq t/2$, otherwise we can find u, v with $\text{dist}(u, V) = \text{dist}(v, V) = t/2$ and $|u - v| \leq t$ such that η, u, v are connected which would contradict the fact that η belongs to \mathcal{P} . In particular for $n > d(V) + t/2$, we have $\mathcal{P}_n = \mathcal{P} \subset V^{<t/2}$, where $V^{<t/2} = \{x, \text{dist}(x, V) < t/2\}$. Note that if $V \neq \emptyset$, for all n , we have $\mathcal{P}_n \subset V^{<t/2}$ and hence we have

$$\Phi(\mathcal{P}_n) \leq 3 + C_t(d(V) + t/2)^2,$$

and the rest of the proof is similar with the use of Lemma 4.1 of [121].

3.4 Proof of Lemma 3.2.3

To simplify the notations and in order to keep them as close as possible to the usual notations in percolation, we denote by \mathbb{P}_t the probability measure $\mathbb{P}_{1, t}^{O, t}$.

The occupied component is defined by $\Xi_t = \cup_{x \in \Phi \circ \underline{t}} B(x, t/2)$. An *occupied path* is a path contained in Ξ_t and a *vacant path* is a path contained in Ξ_t^c . We say there is a *horizontal occupied crossing* of a rectangle $R = [a, b] \times [c, d]$ if there is a path in $\Xi_t \cap R$ from $\{a\} \times [c, d]$ to $\{b\} \times [c, d]$. Vertical crossings and vacant crossings are defined analogously.

We define

$$\sigma((n, m), i, t) = \mathbb{P}_t(\exists \text{ an occupied crossing in direction } i \text{ of } [0, n] \times [0, m]),$$

$$\sigma^*((n, m), i, t) = 1 - \sigma(n, m, i, t) = \mathbb{P}_t(\exists \text{ a vacant crossing in direction } i \text{ of } [0, n] \times [0, m]),$$

where direction 1 (resp. 2) means horizontal (resp. vertical). It follows from Lemma 3.3 of [121] that there exists C_1, C_2 and $\varepsilon = (9e)^{-120} > 0$ such that if

$$\sigma((L, 3L), 1, t) \leq \varepsilon, \tag{3.7}$$

then we have

$$\mathbb{P}_t \left(S(L) \rightsquigarrow^o \partial S(kL) \right) \leq C_1 e^{-C_2 k}. \tag{3.8}$$

Similarly if (3.7) holds with σ replaced by σ^* , then (see Lemma 4.1 of [121]),

$$\mathbb{P}_t \left(S(L) \rightsquigarrow^v \partial S(kL) \right) \leq C_1 e^{-C_2 k}.$$

Thanks to Russo-Seymour-Welsh theorem of Roy for vacant crossings ([121] Theorem 4.2), we can find $\delta > 0$ such that

$$\sigma((L, L), 1, t) = 1 - \sigma^*((L, L), 1, t) \leq \delta,$$

implies (3.7) and similarly for σ replaced by σ^* thanks to the RSW theorem of Alexander for occupied crossings (Theorem 2.1 of [6]).

Following Kesten [103], we define for $\delta > 0$ defined above:

$$L(t) = \begin{cases} \min\{n : \sigma((n, n), 1, t) \geq 1 - \delta\} & \text{if } t > r_c \\ \min\{n : \sigma((n, n), 1, t) \leq \delta\} & \text{if } t < r_c. \end{cases}$$

$L(t) = n$ can be understood as the critical range at which $G_t^O \cap S(n)$ and $G_{r_c}^O \cap S(n)$ start to differ significantly. It is good to note that $L(t)$ goes to infinity as t goes to r_c .

It should now be clear that (see Figure 3.1), under \mathbb{P}_t :

$x \in \mathcal{P}$ if and only if

1. there exist two occupied paths, r_1 (resp. r_3), from O to $B(x, t/2)$ (resp. from \underline{t} to $B(x, t/2)$);
2. there exist two vacant paths r_2^* and r_4^* from x to $\underline{t}/2$, r_1 and r_3 separate r_2^* and r_4^* .

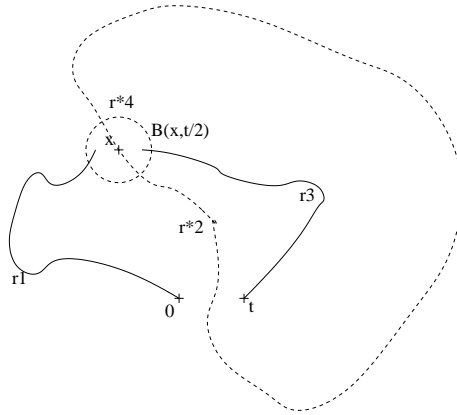

Figure 3.1: In solid line occupied paths and in dashed vacant paths.

For any rectangle R for which $B(v, t/2)$ lies inside R , we define the events:

$\Gamma(v, R) = \{ \text{there exist two occupied paths } r_1 \text{ and } r_3 \text{ from } B(v, t/2) \text{ to } \partial R \text{ and two vacant paths } r_2^* \text{ and } r_4^* \text{ from } B(v, t/2) \text{ to } \partial R; \text{ the paths } r_1, r_3, r_2^*, r_4^* \text{ are all contained in the interior of } R \text{ except for their endpoint on } \partial R; r_1 \text{ and } r_3 \text{ separate } r_2^* \text{ and } r_4^*. \}$

$\Omega(v, R) = \{ \text{there exist two paths } r_1 \text{ and } r_3 \text{ from } B(v, t/2) \text{ to the left and right edge of } R, \text{ respectively, and two paths } r_2^* \text{ and } r_4^* \text{ on } G^* \text{ from } B(v, t/2) \text{ to the top and bottom edge of } R. \}$

In the literature, if $\Gamma(v, R)$ occurs, the point v is called a *four-arm*.

Clearly if $x \in \mathcal{P}$, the events $\Gamma(x, R_x)$ and $\Gamma(\underline{t}/2, R_t)$ occurs for any rectangle R_x (with side size larger than $t/2$) such that $x \in R_x$ and $O, \underline{t} \notin R_x$ and any rectangle R_t such that $\underline{t}/2 \in R_t$ and $x \notin R_t$. In particular if we can chose R_x and R_t such that $R_x^{t/2} \cap R_t^{t/2} = \emptyset$, then we have

$$\mathbb{P}_t(x \in \mathcal{P}) \leq \mathbb{P}_t(\Gamma(x, R_x))\mathbb{P}_t(\Gamma(\underline{t}/2, R_t)).$$

We will use this upper bound for small values of $\|x\| \leq L(t)$. For large value of $\|x\| > L(t)$, we will use

$$\mathbb{P}_t(x \in \mathcal{P}) \leq \mathbb{P}_t(\Gamma(x, R_x))\mathbb{P}_t(\Gamma(\underline{t}/2, R_t))\mathbb{P}_t(R_x \rightsquigarrow^o R_t),$$

for well-chosen rectangles R_x and R_t .

Then Lemma 3.2.3 will follow from the following results. The notation $f(t) \asymp g(t)$ means that there exists C such that as t tends to r_c : $1/Cf(t) \leq g(t) \leq Cf(t)$.

Lemma 3.4.1 *If $t \leq n \leq L(t)$ then uniformly in x ,*

$$\mathbb{P}_t(\Gamma(x, x + S(n))) \leq C\mathbb{P}_{r_c}(\Omega(O, S(n))).$$

Lemma 3.4.2 *If $n \leq L(t)$:*

$$|\sigma((n, n), 1, t) - \sigma((n, n), 1, r_c)| \asymp |t - r_c|n^2\mathbb{P}_{r_c} \left(\Omega(O, S(n)) \right),$$

and in particular:

$$|t - r_c|^{-1} \asymp L(t)^2\mathbb{P}_{r_c} \left(\Omega(O, S(L(t))) \right).$$

Lemma 3.4.3 *There exists $\nu > 0$ such that*

$$L(t) \geq C|t - r_c|^{-\nu}. \tag{3.9}$$

There exists $\delta > 0$ such that

$$\mathbb{P}_{r_c}(\Omega(O, S(n))) \leq Cn^{-1/\delta}. \tag{3.10}$$

The proof of Lemma 3.4.3 is postponed to the next paragraph.

We now show how Lemma 3.2.3 follows from these results.

For $z = (z_1, z_2) \in \mathbb{Z}^2$, we define

$$S_z = [(z_1 - 1)L, (z_1 + 1)L] \times [(z_2 - 1)L, (z_2 + 1)L].$$

We have

$$\begin{aligned} \mathbb{E}_t\nu(\mathcal{P}) &= \int_{\mathbb{R}^2} \mathbb{P}_t(x \in \mathcal{P})dx \\ &\leq \underbrace{8t^2 + \int_{S(L) \setminus S(8t)} \mathbb{P}_t(x \in \mathcal{P})dx}_I + \underbrace{\sum_{z \in \mathbb{Z}^2 \setminus \{0\}} \int_{S_z} \mathbb{P}_t(x \in \mathcal{P})dx}_J. \end{aligned}$$

We first consider I . Let $R_x = x + S(|x|/3)$ and $R_t(x) = \underline{t}/2 + S(|x|/3)$, we have for $x \in S(L) \setminus S(8t)$,

$$\begin{aligned} \mathbb{P}_t(x \in \mathcal{P})dx &\leq \mathbb{P}_t(\Gamma(x, R_x))\mathbb{P}_t(\Gamma(\underline{t}/2, R_t(x))) \\ &\leq C\mathbb{P}_{r_c}(\Omega(O, S(|x|/3)))^2, \end{aligned}$$

where the last inequality follows from Lemma 3.4.1. Hence we have $I \leq C \int_{S(L) \setminus S(8t)} \mathbb{P}_{r_c}(\Omega(O, S(|x|/3)))^2 dx$. Now take $0 < \eta < 1/(2\delta)$, with δ as in Equation (3.10), we have

$$\begin{aligned} & \int_{S(L) \setminus S(8t)} \mathbb{P}_{r_c}(\Omega(O, S(|x|/3)))^2 dx \\ &= \int_{S(L) \setminus S(8t)} \mathbb{P}_{r_c}(\Omega(O, S(|x|/3)))^{1-\eta} \mathbb{P}_{r_c}(\Omega(O, S(|x|/3)))^{1+\eta} dx \\ &\leq C \int_{S(L) \setminus S(8t)} |t - r_c|^{-1+\eta} x^{-2(1-\eta)} x^{-(1+\eta)/\delta} dx \\ &\leq C |t - r_c|^{-1+\eta}, \end{aligned}$$

where in the first inequality we use Lemma 3.4.2 for the upper bound of the first term and Equation (3.10) for the second term.

For $z \in \mathbb{Z}^2$ and $x \in S_z$, we define $R'_x = x + S(L/3)$ and $R'_t = \underline{t}/2 + S(L/3)$, then we have

$$\begin{aligned} \mathbb{P}_t(x \in \mathcal{P}) &\leq \mathbb{P}_t(\Gamma(x, R'_x)) \mathbb{P}_t(\Gamma(\underline{t}/2, R'_t)) \mathbb{P}(S(L) \rightsquigarrow^o S(\min(z_1, z_2)L)^c) \\ &\leq C \mathbb{P}_{r_c}(\Omega(O, S(L/3)))^2 \mathbb{P}(S(L) \rightsquigarrow^o S(\min(z_1, z_2)L)^c) \end{aligned}$$

Hence we have

$$\begin{aligned} \sum_{z \neq 0} \int_{S_z} \mathbb{P}_t(x \in \mathcal{P}) dx &\leq CL^2 \mathbb{P}_{r_c}(\Omega(O, S(L/3)))^2 \sum_{z \neq 0} C_1 e^{-C_2 \min(z_1, z_2)} \\ &\leq CL^2 \mathbb{P}_{r_c}(\Omega(O, S(L)))^2, \end{aligned}$$

where the first inequality follows from Equation (3.8). Now from Lemma 3.4.2, we get $L^2 \mathbb{P}_{r_c}(\Omega(O, S(L)))^2 \leq C |t - r_c|^{-1} \mathbb{P}_{r_c}(\Omega(O, S(L)))$. Now from Lemma 3.4.3, we have

$$\mathbb{P}_{r_c}(\Omega(O, S(L))) \leq C |t - r_c|^{\nu/\delta},$$

which gives

$$J \leq C |t - r_c|^{-1+\nu/\delta}.$$

3.4.1 Proof of Lemma 3.4.3

We start by proving Inequality (3.10). Notice that

$$\mathbb{P}_{r_c}(\Omega(O, S(n))) \leq \mathbb{P}_{r_c}(O \rightsquigarrow^o \partial S(n)).$$

For discrete percolation, it is a classical result that $\mathbb{P}_{r_c}(O \rightsquigarrow^o \partial S(n)) \leq C n^{-1/\delta}$ for some $\delta > 0$ (see Theorem 11.89 in Grimmett [81]). With slight changes, the proof extends to continuum percolation. For the sake of completeness, we sketch the argument as it is presented in Grimmett's book. By Theorem 3.4 in Alexander [6], there exists $\epsilon > 0$ such that for all $n > 2r_c$ and $i \in \{1, 2\}$:

$$\sigma^*((3n, n), i, r_c) \geq \epsilon.$$

Let $LR^*((n, m))$ denote the event that there exists a left-right vacant crossing of the box $[0, n] \times [0, m]$ and $O^*(n)$ the event that there exists a vacant closed circuit in $S(3n) \setminus S(n)$ containing O in its interior. By FKG inequality we have (see Lemma 11.75 in Grimmett [81]), for all $n > 2r_c$:

$$\mathbb{P}_{r_c}(O^*(n)) \geq \mathbb{P}_{r_c}(LR^*(3n, n))^4 \geq \epsilon^4.$$

Let $u_0 = 2r_c + 1$ and for $k \geq 1$, $u_k = 3u_{k-1} + r_c$, we notice that the events $\{O^*(u_k)\}_{k \in \mathbb{N}}$ are independent, hence for all $k \geq 0$,

$$\begin{aligned} \mathbb{P}_{r_c}(O \rightsquigarrow^o \partial S(3u_k)) &\leq \mathbb{P}_{r_c}(O^*(u_l) \text{ does not occur for } 0 \leq l \leq k) \\ &\leq (1 - \epsilon^4)^{k+1}. \end{aligned}$$

Now, let $n \in \mathbb{N}$ and k_n such that: $3u_{k_n} \leq n < 3u_{k_n+1}$, it follows that:

$$\mathbb{P}_{r_c}(O \rightsquigarrow^o \partial S(n)) \leq \mathbb{P}_{r_c}(O \rightsquigarrow^o \partial S(3u_{k_n})) \leq (1 - \epsilon^4)^{k_n+1}.$$

u_k is an arithmetico-geometric sequence and $u_k = 3^k(u_0 + r_c/2) - r_c/2$, hence as n goes to infinity $k_n \sim \ln n / \ln 3$ and (3.10) follows.

It remains to check (3.9). By Lemma 3.4.2, there exists C such that, in a neighbourhood of r_c :

$$|t - r_c|^{-1} \leq CL(t)^2 \mathbb{P}_{r_c} \left(\Omega(O, S(L(t))) \right).$$

Then using Inequality (3.10),

$$|t - r_c|^{-1} \leq CL(t)^{2-1/\delta},$$

and we obtain precisely Inequality (3.9).

3.5 A comment on critical exponents and minimal spanning tree

To simplify notations, we consider in this section a discrete percolation model. For $x \in \mathbb{Z}^d$, we write x_i for the i^{th} coordinate of x . The norm $|\cdot|$ is defined by

$$|x| = \max_{i=1}^d |x_i|.$$

The \mathbb{Z}^d lattice is the graph $G = (\mathbb{Z}^d, \mathbb{E}^d)$ with vertex set \mathbb{Z}^d and edge set $\mathbb{E}^d = \{(x, y) : |x - y| = 1\}$.

On each edge $e \in \mathbb{E}^d$ we define a length $\ell(e) = \xi_e$ and the edge lengths are iid random variables whose common distribution ξ has finite mean, a bounded continuous density function bounded by f .

We may assume without loss of generality that the weight of the edges is uniform on $[0, 1]$ and we denote by \mathbb{P} the corresponding (product) probability. Let $O = (0, 0)$, $\mathbf{1} = (1, 0)$ and e_1 is the edge $(O, \mathbf{1})$ and ℓ_1 its length. For $p \in [0, 1]$, under \mathbb{P}_p , $\ell_1 = p$ and an edge is said to be open (resp. closed) if $\ell(e) \leq p$.

In two dimension, it is widely believed that the scaling relations do not depend on the graph under consideration. It has been proved (see Smirnov and Werner [144]) for the triangular lattice that the following critical exponents exist:

$$\xi^*(p) = |p - p_c|^{-4/3+o(1)} \quad \text{and} \quad L(p) = |p - p_c|^{-4/3+o(1)}. \quad (3.11)$$

where as $x \rightarrow \infty$,

$$\mathbb{P}_p(0 \text{ is connected to } x \text{ by a finite cluster}) = \exp(-x/\xi^*(p) + o(x)),$$

As it has been first pointed in Alexander [7], the MST is closely related to percolation. It is therefore natural to expect that the critical exponents have a key role in the intrinsic properties of the MST. We illustrate this remark on a simple functional of the MST. Let G^* be the dual

graph of G on the vertex set $(1/2, 1/2) + \mathbb{Z}^2$: $e^* \in \mathcal{G}^*$ is the edge that crosses $e \in \mathcal{G}$. The weight associated to the dual edge e^* of e is $\ell(e^*) = 1 - \ell(e)$. The MST is a.s. a tree, and we define:

$$\Delta = \sum_{v \in \mathbb{Z}^2} \mathbf{1}(v \in \Pi(O, \mathbf{1})),$$

where $\Pi(O, \mathbf{1})$ is the set of vertices in the MST connecting O to $\mathbf{1}$. Δ is the length of the path $\Pi(O, \mathbf{1})$.

Let $e_1^* = (u^*, v^*)$ be the dual of the edge $e_1 = (O, \mathbf{1})$. Note that, by FKG inequality:

$$\begin{aligned} \mathbb{P}_p(\Delta \geq n) &\geq \mathbb{P}_p(u^* \rightsquigarrow (0, \lceil n/2 \rceil) \text{ by a finite cluster and } v^* \rightsquigarrow (0, -\lceil n/2 \rceil) \text{ by a finite cluster}) \\ &\geq \mathbb{P}_p(u^* \text{ is connected to } (0, \lceil n/2 \rceil) \text{ by a finite cluster})^2 \\ &\geq \exp(-n/\xi^*(1-p) + o(n)) \end{aligned}$$

We then write:

$$\begin{aligned} \mathbb{E}\Delta &= \int_0^1 \sum_{n \geq 0} \mathbb{P}_p(\Delta \geq n) dp \\ &\geq C \int_0^1 \xi^*(p) dp. \end{aligned}$$

We deduce that if Equation (3.11) holds true:

$$\mathbb{E}\Delta = \infty.$$

Note that the same reasoning gives also $\mathbb{E}\rho = \infty$ where $\rho = \max\{|v| : v \in \Pi(O, \mathbf{1})\}$. Indeed, we have $\mathbb{P}_p(\rho \geq n) \geq \mathbb{P}_p(u^* \text{ is connected to } (0, n) \text{ by a finite cluster})^2$.

These simple facts are examples of the relation between the MST and the critical exponents in percolation. A more general study of this phenomenon could be carried on. The following lemma would allow to treat the case $p < p_c$ and $p > p_c$ similarly:

Lemma 3.5.1 *The dual graph of the MST of G is also the MST of G^* .*

Part II

Spatial Random Access Networks

Chapter 4

Random Multi-access Algorithms, a Mean Field analysis

Résumé Nous effectuons une analyse de type "champ moyen" pour une classe d'algorithmes multi-accès aléatoires avec "back-off" exponentiel. En particulier, nous prouvons que l'itération du point fixe de Bianchi est bien justifiée dans la limite où le nombre d'utilisateurs actifs devient grand.

Abstract We perform a mean field analysis of a class of random multi-access algorithms with exponential back-off. In particular we prove that the Bianchi's fix point iteration is indeed justified in the limit when the number of active users is large.

4.1 Introduction

Random multi-access protocols, from the first version of Abramson's ALOHA algorithm [1] to the most recent protocols in IEEE802.xx standards [94], have concentrated a lot of research efforts. These efforts even increased recently due to the development of decentralized random access protocols for wireless Local Access Networks (LANs) and Ad-Hoc networks. However, theoretical results characterizing the stability and the performance of such protocols are quite rare, due to the extreme complexity arising because of the inherent interaction between sources.

In analyzing random access protocols, we can distinguish different kinds of models. First infinite population models where users are assumed to arrive arbitrarily and randomly in the system according to some point processes. In these models, each user generally has a single packet to transmit and leaves the system after successful transmission. In these scenarios, stability of protocols received a lot of attention: for example, the exponential backoff algorithm is unstable for all positive user arrival rate, this was first conjectured by Kelly [100] and proved by Aldous [3]. Other algorithms, see for example proposals by Hajek-van Loon [86], proved to stabilize the system for non-zero user arrival rates.

Other models consider a finite population: the number of users is fixed. In this class of models, we can further distinguish two cases: saturated sources where users always have a packet to send and unsaturated sources where packet arrivals are governed by some exogenous arrival processes. The first case corresponds more or less to data traffic, where the congestion control mechanism ensures that buffers are never empty, whereas the second case is more appropriate in modelling streaming traffic. In case of unsaturated sources, stability is again a major issue, please refer to the work by Håstad et al. [90] and references therein for a review of existing results and open issues.

In the present chapter we consider a finite number of saturated sources. In this context, the stability analysis is simplified, because queues are not considered. The major issue is then to determine the performance of protocols, i.e., we would like to evaluate the throughput of the system and of each source, packet transmission delay, ... These performance parameters are largely unknown. This is due to the fact that the inherent interactions between sources have proven to be extremely complex to model and analyze. A very popular approach to circumvent this difficulty consists in decoupling the source behaviors, i.e., assuming that the (re)-transmission processes of the different sources are mutually independent. This assumption allows one to derive explicit estimates of the performance. This approach was for example applied by Bianchi [29] to analyze the IEEE 802.11 Decentralized Coordination Function (DCF) algorithm and since then has been widely used to accurately predict the performance of similar protocols. Using mean field techniques, we prove that, for a wide range of random back-off algorithms, the decoupling assumption is asymptotically exact as the number of sources grows. In the specific case of exponential back-off algorithm (the DCF is based on this algorithm), the mean field analysis provides the transient and stationary distributions of the (re)-transmission processes.

The remainder of this chapter is organized as follows. In Section 4.2 we introduce the finite-source model and present the basic principle for random back-off algorithms. In Section 4.3 the mean field results, that justify the decoupling approach, are presented. Section 4.4 contains the proofs of the main results.

Notations. Let \mathcal{S} be a separable, complete metric space, $\mathcal{P}(\mathcal{S})$ denotes the space of probability measures on \mathcal{S} . $\mathcal{L}(X)$ is the law of the \mathcal{S} -valued random variable X . $D(\mathbb{R}^+, \mathcal{S})$ the space of right-continuous functions with left-handed limits, with the Skorohod topology [30].

4.2 Random back-off algorithms

We consider N users sharing a common access channel in a decentralized manner. Time is slotted and users are assumed to be synchronized. We consider saturated users only, which means that each user has always a packet to transmit. For data traffic, this assumption is more realistic than to assume that each user generates packets according to some predefined point process.

Each user runs a back-off timer. When a user is in stage $s \in \mathbb{N}$, her/his back-off timer is chosen according to a geometric random variable with mean W_s slots. The back-off timer is decremented at each slot where the channel is idle, until it reaches 0 in which case, the user attempts to use the channel. If the transmission is successful, the stage becomes $S(s)$ where $S : \mathbb{N} \rightarrow \mathbb{N}$ is a non-increasing function. If a collision occurs the stage becomes $C(s)$, where $C : \mathbb{N} \rightarrow \mathbb{N}$ is an increasing function. Then a new back-off timer is chosen. The assumption that the back-off timer is chosen according to a geometric r.v. is not crucial, and we believe the derived results hold for general distributions. The geometric distribution simplifies the analysis, since given that her/his stage is s , a user will attempt the channel with probability $p_s = 1/W_s$. Then, at time slot t , the state of the system is fully described by the attempt probabilities of all users, $p_i^N(t)$, $i = 1, \dots, N$. The set of possible values for the attempt probabilities is denoted by \mathcal{B} . For the sake of simplicity we assume that \mathcal{B} is at most denumerable. We denote by $p_0 = \sup \mathcal{B}$ the maximum attempt probability. We may re-define functions S and $C : \mathcal{B} \rightarrow \mathcal{B}$ expressing a successful and a collision respectively: Given that the attempt probability of a user is p and that she/he attempts to use the channel, the attempt probability becomes $S(p)$ (resp. $C(p)$) in case of successful transmission (resp. collision).

Finally, the evolution of the state of the system is described by the following recursion: for all i and t ,

$$p_i^N(t+1) = p_i^N(t)1_{U_i(t) > p_i^N(t)} + \left(S(p_i^N(t)) \prod_{j \neq i} 1_{U_j(t) > p_j^N(t)} + C(p_i^N(t))(1 - \prod_{j \neq i} 1_{U_j(t) > p_j^N(t)}) \right) 1_{U_i(t) \leq p_i^N(t)}, \quad (4.1)$$

where the $U_i(t)$'s are i.i.d. r.v. uniformly distributed on $[0, 1]$. Having geometric backoffs implies that these r.v. are of course independent of the r.v. $U_i(s)$, $i = 1, \dots, N$, for all $s < t$.

Example 4.2.1 (Exponential backoff) *Most of MAC protocols use a so-called exponential backoff procedure. This is the case for the Ethernet or for the DCF function in wireless LANs. For these protocols the attempt probabilities are values of the set $\mathcal{B} = \{p_0 \times 2^{-k}, k \in \mathbb{N}\}$ and the functions S and C are defined by:*

$$S(p) = p_0 \quad \text{and} \quad C(p) = \max(p/2, p_0 \times 2^K).$$

K may be finite or not. Unless otherwise mentioned, $K = \infty$.

We study the large N asymptotics. To this aim, we need an adequate renormalization. Note first that when the number of users grows large, the stationary probability a user attempts to use the channel must decrease and ultimately tend to zero, otherwise the global throughput will become negligible. Then, the mean time between two consecutive changes in the value of the backoff parameter is roughly inversely proportional to the stationary attempt probability. The above observations suggest the following renormalization:

$$q_i^N(t) \equiv N \times p_i^N[N \times t] \quad \text{where } [x] \text{ denotes the greatest integer in } x. \quad (4.2)$$

The set of possible values for $q_i^N(t)$ is \mathcal{B} . In case of Examples 1 and 2, it means that p_0 is replaced by p_0/N . In general, it means that the set of possible values for $p_i^N(t)$ becomes $\{p/N, p \in \mathcal{B}\}$. The process $q_i^N(\cdot)$ may be seen as a $D(\mathbb{R}^+, \mathcal{B})$ -valued process.

4.3 Convergence theorems

4.3.1 Transient behavior

The following theorem constitutes the main result of the chapter and states that when the number of sources become large, the backoff timers of all sources evolve independently from each other. In short, users behave independently when the number of users grows. The result also identifies the limit behavior of the distribution of the backoff timers.

Theorem 4.3.1 *We assume that the initial values $q_i^N(0)$, $i = 1, \dots, N$, are exchangeable and chaotic. This means the empirical measure μ_0^N of the $q_i^N(0)$ converges weakly to a deterministic limit Q_0 . In practice the assumption that the $q_i^N(0)$ are i.i.d. suffices. There exists a probability measure Q on $D(\mathbb{R}^+, \mathcal{B})$ such that for all subset $I \subset \mathbb{N}$ of finite cardinal $|I|$,*

$$\lim_{N \rightarrow \infty} \mathcal{L}((q_i^N(\cdot))_{i \in I}) = Q^{\otimes |I|} \quad \text{weakly in } \mathcal{P}(D(\mathbb{R}^+, \mathcal{B})^{|I|}). \quad (4.3)$$

To establish this result, we use the method developed by Sznitman [149] and further investigated by Graham [80]. The empirical measure on path space, with samples in $\mathcal{P}(D(\mathbb{R}^+, \mathcal{B}))$, is defined as

$$\mu^N = \frac{1}{N} \sum_{i=1}^N \delta_{q_i^N}, \quad (4.4)$$

where q_i^N stands for the process $q_i^N(\cdot)$. From Sznitman [149] Proposition 2.2, we know that (4.3) is equivalent to:

$$\lim_{N \rightarrow \infty} \mathcal{L}(\mu^N) = \delta_Q \quad \text{weakly in } \mathcal{P}(\mathcal{P}(D(\mathbb{R}^+, \mathcal{B}))). \quad (4.5)$$

Moreover, (4.5) allows us to consider functionals on $D(\mathbb{R}^+, \mathcal{B})$ such as the indicator of the event that a sample path backs off more than b in a finite time interval $[0, T]$. Let X denote a canonical trajectory in $D(\mathbb{R}^+, \mathcal{B})$. Let ϕ denote this functional on X . Then $\langle \mu^N, \phi \rangle$ is the proportion of the particles that back off more than b over the time interval b . If we studied the weaker convergence of $\mu_t^N \rightarrow Q(t)$ then we could not obtain sample path information like this.

For a large class of protocols such as the exponential backoff protocol, we are also able to characterize the evolution of the distribution of the backoff of a source when the number of sources grows large, i.e., to evaluate the marginals of Q .

Theorem 4.3.2 *In case of exponential backoff, the marginals of Q satisfy the following set of differential equations: define by $Q_k(t) \equiv Q(t)(\{2^{-k}p_0\})$,*

$$\frac{dQ_k}{dt}(t) = 2^{1-k}p_0 \left(Q_{k-1}(t)(1 - \exp(-\sum_{i=0}^{\infty} 2^{-i}p_0Q_i(t))) - \frac{Q_k(t)}{2} \right), \quad \text{for all } k \geq 1, \quad (4.6)$$

$$\frac{dQ_0}{dt}(t) = \sum_{k=0}^{\infty} 2^{-k}p_0Q_k(t) \exp(-\sum_{i=0}^{\infty} 2^{-i}p_0Q_i(t)) - p_0Q_0(t). \quad (4.7)$$

4.3.2 Stationary regimes

We now investigate the system behavior in equilibrium. We consider here exponential backoff protocols only. We first prove that when the number of sources N is fixed, the backoff process $(q_i^N(t))_i$ is ergodic. The theorem below is proved assuming $p_0 < \ln 2$, which is consistent with usual MAC protocols (in case of the DCF, $p_0 = 1/32$). The results actually hold for any p_0 .

Theorem 4.3.3 *In case of exponential backoff, the Markov chain $(q_i^N(t))_i$ is positive recurrent. Furthermore the set of laws of $q_i^N(0)$ in equilibrium is tight, i.e., $\mathcal{L}_{\text{st}}(q_i^N(0))$ is tight.*

Proof. It can be easily proved that the considered Markov chain is irreducible. Consider an arbitrary source, say source 1. Its backoff is less than that in a fictive system, where all other sources attempt to use the channel with highest probability p_0/N . In this fictive system, $\log(Nq_1^N(t)/p_0)$ evolves as a Markov chain with transition matrix $P = (p_{ij})$ defined by: $p_{00} = 1 - p_0(1-a)/N$, $p_{01} = p_0a/N$ and $p_{i0} = p_02^{-i}(1-a)/N$, $p_{ii} = 1 - p_0^2^{-i}/N$, $p_{ii+1} = p_02^{-i}a/N$. $a = 1 - (1 - p_0/N)^{N-1} < 1/2$ (since $p_0 < \ln 2$). The analysis of this Markov chain is straightforward, it is positive recurrent and we can also prove that in this fictive system, the mean value of $q_1^N(0)$ in stationary regime is $p_0(1 - 2a)/(1 - a)$. We deduce that $(q_i^N(t))$ in the actual system is also ergodic and that $E_{\text{st}}[q_1^N(0)] \leq p_0(1 - 2a)/(1 - a)$, which provides the desired tightness. \square

It can be easily proved that the dynamic system described by differential equations (4.6)-(4.7) admits a unique equilibrium $q_{\text{st}} = (q_k)_k$ defined by:

$$\forall k, \quad q_k = (2(1 - e^{-S}))^k q_0, \quad q_0 = S e^{-S} \quad \text{and} \quad S = \sum_k 2^{-k} q_k.$$

The stability of this equilibrium point is obtained remarking that the gradient matrix of the dynamical system has eigenvalues with strictly negative real part at the equilibrium point. *We let the study of the global stability of (4.6)-(4.7) for future work. In the following we will assume that it is globally stable.* We are now able to characterize the system behavior in equilibrium when the number of sources grows large.

Theorem 4.3.4 *In equilibrium, for all subset $I \subset \mathbb{N}$ of finite cardinal $|I|$,*

$$\lim_{N \rightarrow \infty} \mathcal{L}_{\text{st}}((q_i^N(\cdot))_{i \in I}) = q_{\text{st}}^{\otimes |I|} \quad \text{weakly in } \mathcal{P}(D(\mathbb{R}^+, \mathcal{B})^{|I|}), \quad (4.8)$$

This theorem is proved in Section 4.4. It states that in equilibrium, the behavior of sources are independent. It then implies that the decoupling approach used by Bianchi is asymptotically correct when the number of sources grows large.

4.4 Proof of Theorems 4.3.1 and 4.3.2

4.4.1 Proof of Theorems 4.3.1 and 4.3.2

Step 1. The sequence $\mathcal{L}(\mu^N)$ is tight in $\mathcal{P}(\mathcal{P}(D(\mathbb{R}^+, \mathcal{B})))$. Thanks again to Sznitman [149] Proposition 2.2, we only have to prove that $\mathcal{L}(q_1^N(\cdot))$ is tight in $\mathcal{P}(D(\mathbb{R}^+, \mathcal{B}))$. The jumps of $q_1^N(\cdot)$ are included in those of a Poisson process of intensity p_0 . the jump sizes are bounded (by 1). We conclude by the tightness criterion in Ethier-Kurtz [61] p 128.

Step 2. We can mimic the Step 2 in [80]. We show that any accumulation point of $\mathcal{L}(\mu^N)$ satisfies a certain martingale problem. For $f \in L^\infty(\mathcal{B})$, the bounded and forcibly measurable functions of $\mathcal{B} \rightarrow \mathbb{R}$, define $f^s(q) = f(S(q)) - f(q)$ and $f^c(q) = f(C(q)) - f(q)$ (s and c stand for *success* and *collision*, respectively). Now, for $f \in L^\infty(\mathcal{B})$,

$$\begin{aligned} f(q_i^N(t)) - f(q_i^N(0)) &= \sum_{k=0}^{\lfloor Nt \rfloor - 1} (f(q_i^N(\frac{k+1}{N})) - f(q_i^N(\frac{k}{N}))) \\ &= \sum_{k=0}^{\lfloor Nt \rfloor - 1} \mathcal{G}^{f,i,N}(k) + \mu^{f,i,N}(t), \end{aligned}$$

where

$$M^{f,i,N}(t) = \sum_{k=0}^{\lfloor Nt \rfloor - 1} f^s(q_i^N(\frac{k}{N})) \left(1_{\{NU_i(k) \leq q_i^N(\frac{k}{N})\}} \prod_{j \neq i} 1_{\{NU_j(k) > q_j^N(\frac{k}{N})\}} - \frac{q_i^N(\frac{k}{N})}{N} \prod_{j \neq i} (1 - \frac{q_j^N(\frac{k}{N})}{N}) \right) \quad (4.9)$$

$$+ f^c(q_i^N(\frac{k}{N})) \left(1_{\{NU_i(k) \leq q_i^N(\frac{k}{N})\}} (1 - \prod_{j \neq i} 1_{\{NU_j(k) > q_j^N(\frac{k}{N})\}}) - \frac{q_i^N(\frac{k}{N})}{N} (1 - \prod_{j \neq i} (1 - \frac{q_j^N(\frac{k}{N})}{N})) \right).$$

and where

$$\mathcal{G}^{i,N} f(k) = \left[f^s(q_i^N(\frac{k}{N})) \frac{q_i^N(\frac{k}{N})}{N} \prod_{j \neq i} (1 - \frac{q_j^N(\frac{k}{N})}{N}) + f^c(q_i^N(\frac{k}{N})) \frac{q_i^N(\frac{k}{N})}{N} \left(1 - \prod_{j \neq i} (1 - \frac{q_j^N(\frac{k}{N})}{N}) \right) \right],$$

The proofs of the two following lemmas are given at the end of this section.

Lemma 4.4.1 *For the martingale $M^{f,i,N}(t)$ defined at (4.9), the Doob-Meyer Brackets $\langle M^{f,i,N}, M^{f,j,N} \rangle = t \|f\|_\infty \mathcal{O}(1/N)$ as $N \rightarrow \infty$ uniformly in $i \neq j$.*

Lemma 4.4.2 *The martingale $M^{f,i,N}(t)$ defined at (4.9) satisfies*

$$M^{f,i,N}(t) = f(q_i^N(t)) - f(q_i^N(0)) - \int_0^t \mathcal{G}f(\mu_v^N, q_i^N(v)) dv + \epsilon^{f,i,N}(t) \quad (4.10)$$

where

$$\mathcal{G}f(\mu, q) = q \cdot (f^s(q) - f^c(q)) \exp(-\langle Id, \mu \rangle) + q \cdot f^c(q) \quad (4.11)$$

and where $\epsilon_t^{f,i,N} = t \|f\|_\infty \mathcal{O}(1/N)$ uniformly in i .

If indeed μ^N does converge to Q then (4.10) will converge to a solution of a martingale problem. Recall that X denotes a canonical trajectory in $D(\mathbb{R}^+, \mathcal{B})$. A probability Q in $\mathcal{P}(D(\mathbb{R}^+, \mathcal{B}))$ solves the non-linear martingale problem if

$$M_t^f = f(X_t) - f(X_0) - \int_0^t \mathcal{G}f(Q(s), X_s) ds \quad (4.12)$$

is a Q -martingale. It solves the martingale problem starting at q if $Q(0) = Q_0$.

Let Π^∞ be an accumulation point of $\mathcal{L}(\mu^N)$. Let $R \in \mathcal{P}(D(\mathbb{R}^+, \mathcal{B}))$ belong to the support of Π^∞ . Recall as in [80] that the projection map $X \rightarrow X_t$ is R -a.s. continuous for all t except perhaps in at most a countable subset D_R of R_+ . Further, as in [80], we may check that $D = \{t \in R_+ : \Pi^\infty(\{R : t \in D_R\}) > 0\}$ is at most denumerable.

Lemma 4.4.3 *R satisfies the non-linear martingale problem (4.12)*

The continuity of $X \rightarrow X_0$ implies $R_0 = Q_0$, Π^∞ -a.s.. The proof is postponed to the end of the section.

Step 3. We now show the solution to (4.12) is unique so $R = Q$. We can mimic Theorem 3.3 in [80] to show the solution to the martingale problem (4.12) is unique. We remark $\mathcal{G}f(\mu, q) = \int_{\mathcal{B}} (f(y) - f(x)) J(\mu, x, dy)$ where

$$J(\mu, x, dy) = x \exp(-\langle Id, \mu \rangle) (\delta_{S(x)}(dy) - \delta_{C(x)}(dy)) + x \delta_{C(x)}(dy).$$

Next, $\|J(\mu, x, \cdot)\| \leq x \leq p_0$ and

$$\begin{aligned} \|J(\alpha, x, \cdot) - J(\beta, x, \cdot)\| &\leq x|\exp(-\langle Id, \alpha \rangle) - \exp(-\langle Id, \beta \rangle)| \\ &\leq x|1 - \exp(\langle Id, \alpha \rangle - \langle Id, \beta \rangle)| \\ &\leq xC|\langle Id, \alpha \rangle - \langle Id, \beta \rangle| \\ &\leq p_0C\|\alpha - \beta\| \end{aligned}$$

where $\|\cdot\|$ denotes the total variation norm. As in Theorem 3.3 in [80] we use Proposition 2.3 in [80] to establish the solution to the martingale problem (4.12) is unique.

Step 4. We have now proved convergence because any subsequence converges to the same limit Q . We can now identify this limit for the protocols considered in Examples 1 and 2. If Q satisfies the martingale problem then $(Q(t))_{t \geq 0}$ solves the non-linear Kolmogorov equation derived by taking the expected value:

$$\langle f, Q(t) \rangle - \langle f, Q(0) \rangle = \int_0^t \langle \mathcal{G}f(Q(s), q); Q(s) \rangle ds. \quad (4.13)$$

Applying (4.13) to $f = 1_{p_0 2^{-k}}$ for all k , we get the set differential equations (4.6)-(4.7) in case of exponential backoff.

Proof of Lemma 4.4.1.

$M^{f,i,N}(t)$ is a martingale by the Dynkin formula.

Next, we define the following variables : $S_{i,k}^N = 1_{\{NU_i(k) \leq q_i^N(\frac{k}{N})\}} \prod_{j \neq i} 1_{\{NU_j(k) > q_j^N(\frac{k}{N})\}}$ and $C_{i,k}^N = 1_{\{NU_i(k) \leq q_i^N(\frac{k}{N})\}} (1 - \prod_{j \neq i} 1_{\{NU_j(k) > q_j^N(\frac{k}{N})\}})$.

$S_{i,k}^N = 1$ if the user i is the only user accessing the channel at time k and $C_{i,k} = 1$ if a collision occurs for user i at time k . Both these events have a probability less than p_0/N .

Note in particular for $i \neq j$ that :

$$S_{i,k}^N C_{i,k}^N = 0, \quad S_{i,k}^N S_{j,k}^N = 0, \quad S_{i,k}^N C_{j,k}^N = 0 \quad \text{and} \quad P(C_{i,k}^N C_{j,k}^N = 1) = \mathcal{O}(1/N^2), \quad (4.14)$$

where the last equation stands uniformly in i, j .

In the sequel, $E_{U(k)}(\cdot)$ will denote $E(\cdot | (p_i^N(k))_i)$. $E_{U(k)}(S_{i,k}^N)$ and $E_{U(k)}(C_{i,k}^N)$ are bounded by p_0/N . With this notation, we can rewrite as Equation 4.9 as :

$$M^{f,i,N}(t) = \sum_{k=0}^{[Nt]-1} f^s(q_i^N(\frac{k}{N})) (S_{i,k}^N - E_{U(k)} S_{i,k}^N) + f^c(q_i^N(\frac{k}{N})) (C_{i,k}^N - E_{U(k)} C_{i,k}^N) \quad (4.15)$$

To prove Lemma 4.4.1, we first show $EM^{f,1,N}(t)M^{f,2,N}(t)$ tends to 0. Since $(M^{f,i,N}(t))$ is a martingale this product is equal to :

$$\begin{aligned} EM^{f,1,N}(t)M^{f,2,N}(t) &= \sum_{k=0}^{[Nt]-1} E f^s(q_1^N(\frac{k}{N})) (S_{1,k}^N - E_{U(k)} S_{1,k}^N) f^s(q_2^N(\frac{k}{N})) (S_{2,k}^N - E_{U(k)} S_{2,k}^N) \\ &\quad + E f^c(q_1^N(\frac{k}{N})) (C_{1,k}^N - E_{U(k)} C_{1,k}^N) f^c(q_2^N(\frac{k}{N})) (C_{2,k}^N - E_{U(k)} C_{2,k}^N) \\ &\quad + 2E f^c(q_1^N(\frac{k}{N})) (C_{1,k}^N - E_{U(k)} C_{1,k}^N) f^s(q_2^N(\frac{k}{N})) (S_{2,k}^N - E_{U(k)} S_{2,k}^N). \end{aligned}$$

Using (4.14), it appears easily that each term of the sum is bounded by $\|f\|_\infty \mathcal{O}(1/N^2)$ and the lemma follows.

Proof of Lemma 4.4.2.

$$\begin{aligned} \int_0^t \mathcal{G}f(\mu_s^N, q_i^N(s)) ds &= \sum_{k=0}^{[Nt]-1} \int_{[k/N]}^{(k+1)/N} \mathcal{G}f(\mu_s^N, q_i^N(s)) ds + \int_{[Nt]/N}^t \mathcal{G}f(\mu_s^N, q_i^N(s)) ds \\ &= \sum_{k=0}^{[Nt]-1} \int_k^{k+1} \mathcal{G}f(\mu_{w/N}^N, q_i^N(\frac{w}{N})) dw + \frac{1}{N} \int_{[Nt]}^{Nt} \mathcal{G}f(\mu_{w/N}^N, q_i^N(\frac{w}{N})) dw \end{aligned}$$

Hence

$$\begin{aligned} |\epsilon_t^{f,i,N}| &\leq \sum_{k=0}^{[Nt]-1} |\mathcal{G}^{i,N} f(k) - \frac{1}{N} \int_k^{k+1} \mathcal{G}f(\mu_{w/N}^N, q_i^N(\frac{w}{N})) dw| + \frac{1}{N} |\int_{[Nt]}^{Nt} \mathcal{G}f(\mu_{w/N}^N, q_i^N(\frac{w}{N})) dw| \\ &\leq \sum_{k=0}^{[Nt]-1} |\mathcal{G}^{i,N} f(k) - \frac{1}{N} \mathcal{G}f(\mu_{k/N}^N, q_i^N(\frac{k}{N}))| + \frac{1}{N} |\mathcal{G}f(\mu_{k/N}^N, q_i^N(\frac{k}{N}))|. \end{aligned}$$

The last term of this inequality is less than $3p_0 \|f\|_\infty / N$ (since $q_i^N(t) \leq p_0/N$). To finish the proof, it remains to bound the terms appearing in the sum and, giving a closer look at \mathcal{G} , it suffices to bound $\exp(-1/N \sum_{i=1}^N q_i^N(k/N)) - \prod_{i \neq j} (1 - q_i^N(k/N)/N)$ by $\mathcal{O}(1/N)$ uniformly in i, j . We have :

$$|e^{-\frac{1}{N} \sum_{i=1}^N q_i^N(k/N)} - \prod_{i \neq j} (1 - \frac{q_i^N(k/N)}{N})| \leq e^{-p_0} |1 - e^{\frac{q_i^N(k/N)}{N} + \sum_{j \neq i} |\ln(1 - \frac{q_j^N(k/N)}{N}) + \frac{q_j^N(k/N)}{N}|}|.$$

Using for example the inequality for $x \in (0, 1)$, $|\ln(1-x) + x| \leq \frac{x^2}{2(1-x)^2}$, we deduce the required bound.

Proof of Lemma 4.4.3.

We mimic the proof in Step 2 of Theorem 3.4 of [80]. For the sake of completeness, we detail the proof.

Take $0 \leq s_1 < s_2 < \dots < s_k \leq s < t$ outside D and $g \in L^\infty(\mathcal{B}^k)$. Take $f \in L^\infty(\mathcal{B})$. The map

$$\begin{aligned} G : R \in \mathcal{P}(D(\mathbb{R}^+, \mathcal{B})) \\ \rightarrow \left\langle \left(f(X_t) - f(X_s) - \int_s^t \mathcal{G}f(R_u, X_u) du \right) g(X_{s_1}, \dots, X_{s_k}); R \right\rangle \end{aligned}$$

is Π^∞ -a.s. continuous.

Let Π^N be the law of μ^N , following [80], we write :

$$\begin{aligned} \langle G^2, \Pi^N \rangle &= E(G(\mu^N)^2) \\ &= E(G(\frac{1}{N} \sum_{i=1}^N \delta_{q_i^N})^2) \\ &= E \left(\frac{1}{N} \sum_{i=1}^N \left(f(q_i^N(t)) - f(q_i^N(s)) - \int_s^t \mathcal{G}f(\mu_u^N, q_i^N(u)) du \right) g(q_i^N(s_1), \dots, q_i^N(s_k)) \right)^2 \\ &= E \left(\frac{1}{N} \sum_{i=1}^N \left(M^{f,i,N}(t) - M^{f,i,N}(s) - (\epsilon^{f,i,N}(t) - \epsilon^{f,i,N}(s)) \right) g(q_i^N(s_1), \dots, q_i^N(s_k)) \right)^2 \end{aligned} \tag{16}$$

Let $g^{i,N} = g(q_i^N(s_1), \dots, q_i^N(s_k))$ and for a process Y let $Y_{s,t} = Y_t - Y_s$. Using exchangeability, from Equation (4.16) we obtain:

$$\begin{aligned} \langle G^2, \Pi^N \rangle &= E\left(\frac{1}{N} \sum_{i=1}^N \left(M_{s,t}^{f,i,N} - \epsilon_{s,t}^{f,i,N}\right) g(q_i^N(s_1), \dots, q_i^N(s_k))\right)^2 \\ &= \frac{1}{N} E\left((M_{s,t}^{f,1,N} - \epsilon_{s,t}^{f,1,N})g^{1,N}\right)^2 + \frac{N-1}{N} E\left(M_{s,t}^{f,1,N} - \epsilon_{s,t}^{f,1,N}\right)g^{1,N} \left(M_{s,t}^{f,2,N} - \epsilon_{s,t}^{f,2,N}\right)g^{2,N}. \end{aligned}$$

Lemmas 4.4.1 and 4.4.2 imply that $\langle G^2, \Pi^N \rangle$ tends to 0. From Fatou's Lemma, $\langle G^2, \Pi^\infty \rangle \leq \lim_N \langle G^2, \Pi^N \rangle = 0$ and thus Π^∞ -a.s, $G(R) = 0$. Since this holds for arbitrary $0 \leq s_1 < s_2 < \dots < s_k \leq s < t$ outside D and $g \in C_b(\mathcal{B}^k)$ it follows that R satisfies the non-linear martingale problem (4.12).

4.4.2 Proof of Theorem 4.3.4

Let $(q_i^N(0))_i$ with law the invariant law of the system with N users. By symmetry, $(q_i^N(0))_i$ is exchangeable. We define $\Pi^N = 1/N \sum_{i=1}^N q_i^N$. By Theorem 4.3.3, Π_0^N is tight, consider an accumulation point Π_0^∞ . We cannot apply directly Theorem 4.3.1 since we do not know whether the subsequence of Π_0^N converges weakly toward a deterministic limit.

We now circumvent this difficulty. As in step 1 in the proof of Theorem 4.3.1, we deduce from Sznitman [149] Proposition 2.2, that Π^N is tight in $\mathcal{P}(\mathcal{P}(D(\mathbb{R}^+, \mathcal{B})))$. Let R in $\mathcal{P}(D(\mathbb{R}^+, \mathcal{B}))$ in the support of an accumulation point of Π^N . We can prove similarly that Lemma 4.4.3 still holds for R .

By Step 3 of Theorem 4.3.1, the solution of the martingale problem is unique and R solves it with initial condition R_0 . The global stability of (4.6)-(4.7) implies that $\lim_{t \rightarrow +\infty} R_t = q_{st}$. However, by stationarity, Π_t^N and Π_0^N are equal, we deduce immediately that the support Π_0^N is reduced to q_{st} and $R_0 = q_{st}$.

Theorem 4.3.4 is then a consequence of Theorem 4.3.1.

Chapter 5

A Random Multiple Access Protocol with Spatial Interactions

Résumé Nous étudions un protocole d'accès de type aloha où les utilisateurs ont des interactions locales. Nous établissons que le modèle fluide du système satisfait une équation différentielle. Nous prouvons un résultat partiel de stabilité de cette équation différentielle. La condition de stabilité du système est laissée comme une conjecture.

Abstract We analyze an aloha type access protocol where users have local interactions. We establish that the fluid model of the system satisfies a differential equation. We prove a partial result on the stability of this differential equation. The stability region of the system is stated as a conjecture.

5.1 Introduction and the main result

5.1.1 A spatial Aloha

We consider a random spatial service system governed by an ALOHA-type algorithm. More precisely, time is slotted, at each slot ξ_n users arrive at the system, and at each slot every user in the system requires service (transmission) with a certain probability (transmission probability).

Aloha system was first proposed in Abramson [1]. The slotted scheme was introduced in Roberts [139]. We shall consider the latter setting. In conventional slotted Aloha model, there is one server, at the beginning of each time slot n , a total number W_n of users is available and each of them requires service (transmission) with probability $p_n = \frac{C}{W_n}$ independently of the other users. A user can transmit (receive service) only if he is the only user requiring transmission at the slot. Service time is usually assumed to equal 1 so that the server is always free at any moment n . It is easy to show that for this systems the throughput is equal to e^{-1} (if $\mathbf{E}\xi_1 < e^{-1}$ then the Markov Chain $\{W_n\}$ is recurrent, if $\mathbf{E}\xi_1 > e^{-1}$ then it is transient).

One can also consider so-called decentralized algorithms used when the information on number of users present in the system is not available. These algorithms are based upon information about previous time slot: whether there was a conflict, successful transmission or no user required service. For such a system, under independence and exponential moment assumptions for ξ_n , Hajek [85] proved that $\mathbf{E}\xi_n < e^{-1} \approx 0.37$ is necessary and sufficient for the existence of a stable regime. Mikhailov [124] generalized this result by weakening the exponential moment assumption to the requirement that only the second moment need exist, while Foss [66] generalized it further by dropping both this and independence assumptions. We also refer to Douc et al. [60] for a nice survey of the results in various directions and, in particular, in this area.

These analyses ignore the network's spatial diversity and, in particular, the fact that there may be only *partial* interaction between users, depending on the distance between them. The development of decentralized random access protocols for wireless networks has created a new need of theoretical results on the stability and performance of such protocols when the spatial interaction between the sources is taken into account.

In this work, a new model is presented which captures a main feature of wireless networks: the spatial reuse of a common communication channel. This feature brings a new conceptual difficulty in the analysis of the stability of random access protocols.

The remainder of this paragraph is organized as follows. The end of this introduction is devoted to the description of the model and the statement of our main result. In Section 5.2 we prove that the fluid limits of the workload in the system satisfy a differential equation. Section 5.3 is devoted to the behavior of the fluid limits on the boundary on the positive orthant. In Section 5.4 we present the proof of our main result. In Section 5.5 we present a result on the rates of convergence to the stable regime of the system. Section 5.6 contains some interesting results on behaviour of the solutions to the differential equation satisfied by fluid limits. Finally, in Section 5.7 we conclude by some extensions of our model.

5.1.2 Model Description

Let $\mathcal{G} = (\mathcal{V}, \mathcal{E})$ be a non-oriented graph with a finite set of vertices, say $\mathcal{V} = \{1, \dots, K\}$. We suppose that G is connected. We use the standard notion of the graph distance in \mathcal{G} . Denote by D the maximal graph distance in \mathcal{G} (the diameter of \mathcal{G}). For $i \in \mathcal{V}$, let $V_i = \{i\} \cup \{j \in \mathcal{V} : \text{such that } (i, j) \in \mathcal{E}\}$, that is the set of vertices at distance at most 1 in the graph for i .

We introduce the following service system with spatial (neighborhood) interactions associated with the graph \mathcal{G} . We assume that time is slotted, i.e., arrivals and services may occur

only at times $n = 1, 2, \dots$. Suppose that there are service stations at each point of \mathcal{G} . The arrival process is denoted by $A = (A(n))_{n \in \mathbb{N}}$, where $A(n) \in \mathbb{N}^K$ is the number of users arriving at time n at each vertex. For $t > s$, denote by $A(t, s) = \sum_{n=[t]}^{[s]-1} A(n)$ the number of users arriving between time t and $s-$. We suppose that $(A(n))$ is an i.i.d. sequence. We suppose also that $EA_i(n) = \lambda > 0$ for every $i = 1, \dots, K$.

Let $W(n) \in \mathbb{R}_+^K$ be the workload at time n in the system, that is $W_i(n)$ is the number of users at vertex i at time n . At time n , a user at vertex i requires service independently of the others with probability $1/\sum_{j \in V_i} W_j(n)$. This user receives service if he is the only user requiring service in V_i at time n . We suppose that all service times are equal to 1 and that any user leaves the *system* immediately upon the service completion. Let $N_i(n)$ be the number of users requiring service at time n at vertex i . $N_i(n)$ is a Binomial random variable with parameters $\left(W_i(n), \frac{1}{\sum_{j \in V_i} W_j(n)}\right)$ and $(N_i(n)), 1 \leq i \leq K$ are independent variables conditioned on $W(n)$. W is clearly an irreducible Markov Chain on \mathbb{N}^K . We have the following relation on the values of workload at subsequent time instances:

$$W_i(n) = W_i(n-1) + A_i(n) - \mathbf{1}(N_i(n-1) = 1) \prod_{j \in V_i \setminus \{i\}} \mathbf{1}(N_j(n-1) = 0). \quad (5.1)$$

To show explicitly the dependence of $W(n)$ on the initial condition $W(0) = x$ we may sometimes write $W^x(n)$.

If $x_i > 0$, the i -th component of drift vector is given by the following expression:

$$E [W_i(1) - W_i(0) | W(0) = x] = \lambda - \frac{x_i}{\sum_{k \in V_i} x_k} \left(1 - \frac{1}{\sum_{k \in V_i} x_k} \right)^{x_i-1} \prod_{j \in V_i \setminus \{i\}} \left(1 - \frac{1}{\sum_{k \in V_j} x_k} \right)^{x_j}, \quad (5.2)$$

and if $x_i = 0$, then $E [W_i(1) - W_i(0) | W(0) = x] = \lambda$.

We rewrite the expression for the drift vector in the following way:

$$E [W(1) - W(0) | W(0) = x] = \lambda \mathbf{1} - G(x).$$

Here $\mathbf{1}$ is the unit vector ($\mathbf{1}_i = 1$ for all $i \in K$) and G is a function from \mathbb{R}^K to \mathbb{R}^K defined by

$$G_i(x) = \begin{cases} \frac{x_i}{\sum_{k \in V_i} x_k} \left(1 - \frac{1}{\sum_{k \in V_i} x_k} \right)^{x_i-1} \prod_{j \in V_i \setminus \{i\}} \left(1 - \frac{1}{\sum_{k \in V_j} x_k} \right)^{x_j}, & \text{if } x_i > 0, \\ 0, & \text{if } x_i = 0. \end{cases}$$

For $x \in \mathbb{R}^K$, we define $\phi_i(x) = \frac{x_i}{\sum_{j \in V_j} x_j}$. Let $\phi(x) = (\phi_1(x), \dots, \phi_K(x))'$. Note that G_i is bounded by 1 and if $\sum_{k \in V_i} x_k > 0$ then

$$\lim_{t \rightarrow +\infty} G_i(tx) = \tilde{G}_i(x) = \phi_i(x) e^{-\sum_{j \in V_i} \phi_j(x)}.$$

In particular \tilde{G}_i is homogeneous of order 0, i.e., $\tilde{G}_i(cx) = \tilde{G}_i(x)$ for any $c > 0$.

We now make some comments on the model. We assume that the graph \mathcal{G} is $V-1$ regular: the cardinal of V_i is equal to V for all i . First notice that the graph \mathcal{G} is not necessarily completely symmetric. Figure 5.1 shows an example of a 3-regular graph which is not completely symmetric.

Note also that the system is not monotone. Indeed $x \leq y$ (component-wise) does not imply that $W^x(1)$ is dominated stochastically by $W^y(1)$ (check this by coupling). The system is

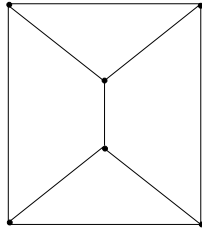

Figure 5.1: A regular graph which is not completely symmetric.

neither monotone with respect to the graph structure. If G_1 is embedded into G_2 , this does not imply that the workload process built on the graph G_1 is dominated stochastically by the workload built on the graph G_2 .

Let G_\emptyset denote the fully isolated graph (that is the set of edges of G_\emptyset is empty). The workload built on G_\emptyset is the usual slotted aloha on each node. Remark that a necessary condition for a user to leave the system is to be the single user in its node to emit. We then deduce the workload built on G_\emptyset is dominated stochastically by the workload built on any other graph. The stability condition of the usual slotted aloha is $\lambda < e^{-1}$, we will thus suppose so far that $\lambda < e^{-1}$.

Similarly, let G_K be the complete graph on \mathcal{V} , the sum of the workloads $\sum_{i=1}^K W_i$ is the usual slotted aloha. A sufficient condition for a user to leave the system is to be the single user in the whole system to emit. Thus the workload built on G_K dominates stochastically the workload built on all its subgraphs. Thus a sufficient condition for stability is $\lambda < e^{-1}/K$.

5.1.3 Main result

We first explain the intuition hidden behind the result.

The access protocol favors an equilibrium of the workload in the network: assume that the workload at node i is much larger than the workload in its neighboring nodes, V_i . Then $\phi_i(x)$ will be close to 1 whereas for all the nodes j in V_i , $\phi_j(x)$ will be close to 0. Thus the workload at node j in V_i will tend to get closer to the workload at node i . This balance mechanism hints that the diagonal $\Delta = \{x \in \mathbb{R}^K : x_1 = x_2 \dots = x_K\}$ is attractive.

If the workload is on the diagonal: $W(0) = c\mathbf{1}$ where $c \in \mathbb{N}^*$, we obtain:

$$E(W(1) - W(0) | W(0) = c\mathbf{1}) = \left(\lambda - \frac{1}{V}\left(1 - \frac{1}{Vc}\right)^{Vc-1}\right)\mathbf{1}.$$

Hence, as c tends to infinity, the drift vector converges to $(\lambda - e^{-1}/V)\mathbf{1}$.

So finally, we end up with the conjecture that if $\lambda < e^{-1}/V$ the Markov chain W is ergodic whereas if $\lambda > e^{-1}/V$, W is transient.

This conjecture is clearly true for G_\emptyset and G_K .

The reasons led to this conjecture appear to be wrong (as will follow from the results of Section 5.6), in general the diagonal is not attractive). However, the conjecture itself is true and we can formulate our main result that will be proved in Section 5.4.

Theorem 5.1.1 *If $\lambda < e^{-1}/V$ the Markov chain W is ergodic.*

A classical strategy to analyse the positive recurrence of this type of Markov chain is via the fluid approximation. We will prove that the fluid approximation satisfies an ordinary differential equation.

5.2 Fluid Approximation Method

5.2.1 General Properties

In what follows, we endow \mathbb{R}^K with the L^1 -norm: $|x| = \sum_{k=1}^K |x_k|$. Let $(x^n), n \in \mathbb{N}$, be a sequence in \mathbb{N}^K such that $\lim_n |x^n| = \infty$. For $t \in [0, T]$, we define:

$$X^n(t) = \frac{W^{x^n}(\lceil |x^n| t \rceil)}{|x^n|}.$$

To simplify the notation, for $t \in \mathbb{R}_+$, we set $W(t) = W(\lceil t \rceil)$.

Let $\mathbb{D}([0, T], \mathbb{R}^K)$ denote the space of càdlàg functions from $[0, T]$ to \mathbb{R}^K endowed with the usual Skorokhod topology, i.e., distance between functions f_1 and f_2 is given by the following expression:

$$d_T(f_1, f_2) = \inf_{t \in [0, T]} \sup \{ |g(t) - t| + \rho(f_1(g(t)), f_2(t)) \},$$

where ρ is the L^1 -metric in \mathbb{R}^K , and the outer infimum is taken over all monotone continuous functions $g : [0, T] \rightarrow [0, T]$ such that $g(0) = 0$ and $g(T) = T$. Denote by $\mathbb{D}([0, \infty))$ the space of \mathbb{R}^K -valued càdlàg functions on $[0, \infty)$ with the metric

$$d(f_1, f_2) = \sum_1^\infty 2^{-T} \frac{d_T(f_1, f_2)}{1 + d_T(f_1, f_2)}.$$

Note that $X^n \in \mathbb{D}([0, T], \mathbb{R}^K)$ for all n .

Lemma 5.2.1 (i) For any sequence x^n such that $|x^n| \rightarrow \infty$, a.s. the family $A = \{(X^n), n \in \mathbb{N}\}$ has a compact closure in the Skorokhod topology and an accumulation point z of A is almost surely continuous.

(ii) Function z is Lipschitz with the constant $K \max\{\lambda, 1\}$.

Proof of Lemma 5.2.1

(i) One can obtain the proof of this assertion following the lines of proof of [53], Theorem 4.1 or [146], Theorem 7.1. Formally, the proofs of mentioned theorems are given for multi-class networks. However, as it is pointed out in [67], the tightness of such families holds under weaker conditions (see [67], Assumption 2.19).

(ii) Since G_i is bounded by 1:

$$\begin{aligned} |X^n(t) - X_i^n(s)| &\leq \max \left\{ \frac{|A(s|x^n|, t|x^n|)|}{|x^n|}, \frac{K|x^n|(t-s)}{|x^n|} \right\} \\ &\leq \max \left\{ \frac{1}{|x^n|} \sum_{k=\lceil |x^n|s \rceil}^{\lceil |x^n|t \rceil} V_k, K(t-s) \right\}, \end{aligned}$$

Where V_k is the total number of arrivals at time k . Since $\{V_k\}_{k \in \mathbb{N}}$ is an i.i.d. sequence and with $EV_k = K\lambda$. By the law of large numbers, the result now follows if we let $n \rightarrow \infty$. \square

Definition 5.2.2 Any accumulation (in Skorokhod topology) point z of the sequence X_n is called fluid limit. The collection of all fluid limits is called the fluid model.

Note that it follows from the definition of X^n and z that $z_i(t) \geq 0$ for all $i = 1, \dots, K$ and for all t .

Corollary 5.2.3 *The trajectories of fluid limits are self-similar. More precisely, for any fluid limit z and for any $u > 0$ such that $\mathbb{P}(|z(u)| > 0) > 0$, the random process $\{\tilde{z}(t), t \geq 0\}$ with conditional distribution*

$$\mathbb{P}(\tilde{z}(t) \in \cdot) = \mathbb{P}\left(\frac{z(u+t)}{|z(u)|} \in \cdot \mid z(u)\right)$$

is also a fluid limit on the set $|z(u)| > 0$.

This result may be obtained following the lines of proof of Stolyar [146], Lemma 6.1. However, the same remark as the one given in the proof of Lemma 5.2.1, (i) applies here.

Definition 5.2.4 *We say that the fluid model is stable if there exists a deterministic time t_0 and $\epsilon \geq 0$, such that for all fluid limits z satisfying $|z(0)| = 1$, $|z(t)| \leq \epsilon$ for $t \geq t_0$ a.s.*

Definition 5.2.5 *The fluid limit is unstable if there exists a positive deterministic constant c such that for all fluid limits, $\liminf_{t \rightarrow \infty} |z(t)|/t > c$ a.s.*

The definition of fluid stability is standard and appears in most papers dealing with the fluid approximation method. Our definition of fluid instability is not usual and unnecessarily restrictive. In our setting, it appeared to be convenient to work with this definition.

5.2.2 Fluid model criterion for stability

Theorem 5.1.1 can be restated via the fluid approximation method.

Lemma 5.2.6 (i) *If the fluid model is stable then W is ergodic.*

(ii) *If the fluid model is unstable then W is transient.*

Proof. (i) One can obtain again the proof of this assertion following the lines of proof of Dai [53] or Stolyar [146] which are given for multi-class networks.

(ii) Theorem 3.2 of Meyn [122] states statement (ii) for multi-class queueing networks. Here again, the Meyn's proof applies also to our framework without major change. □

By Lemma 5.2.6, Theorem 5.1.1 can be restated as:

Theorem 5.2.7 *If $\lambda < e^{-1}/V$ the fluid model is stable whereas if $\lambda > e^{-1}/V$, the fluid model is unstable.*

5.2.3 Fluid Limit Evolution Equation

In what follows we write $\varphi_i(t) = \phi_i(z(t)) = \frac{z_i(t)}{\sum_{j \in V_i} z_j(t)}$.

Theorem 5.2.8 *For any fluid limit z . Assume for all i , $\sum_{j \in V_i} z_j(t) > 0$. If $t > 0$, z_i has a derivative at point t and a right-derivative at 0 if $t = 0$. Moreover, for $t > 0$:*

$$z_i'(t) = \lambda - \varphi_i(t) e^{-\sum_{j \in V_i} \varphi_j(t)} = \lambda - \tilde{G}_i(z_i(t)). \quad (5.3)$$

For $t = 0$ this equation holds with the right derivative.

Under the assumptions of the Theorem, this differential equation admits a unique solution, thus all the converging subsequences of (X^n) converge toward the same deterministic limit.

When the assumption: for all i , $\sum_{j \in V_i} z_j(0) > 0$ is not fulfilled some boundary effects arise. These boundary conditions are discussed in Section 5.3.

Proof of Theorem 5.2.8

(i) We first suppose that $z_i(t) > 0$, we need the following technical result.

Lemma 5.2.9 *There exists $C > 0$ such that $|G_i(x) - \tilde{G}_i(x)| \leq \min(1, C/x_i)$ if $x_i \geq 2$.*

Proof of Lemma 5.2.9

Using that $|e^{-y_1} - e^{-y_2}| \leq |y_1 - y_2|$ for all $y_1, y_2 \geq 0$, we obtain the following:

$$|G_i(x) - \tilde{G}_i(x)| \leq \left| \ln \left(1 - \frac{1}{\sum_{k \in V_i} x_k} \right) \right| + \left| \sum_{j \in V_i} \left(x_j \ln \left(1 - \frac{1}{\sum_{k \in V_j} x_k} \right) + \frac{x_j}{\sum_{k \in V_j} x_k} \right) \right| \quad (5.4)$$

For every j , denote $y_j = \frac{1}{\sum_{k \in V_j} x_k}$. Then, using that $|\ln(1 - y) + y| \leq \frac{y^2}{2(1 - y)^2}$ for $y \in (0, 1)$, we obtain that

$$|G_i(x) - \tilde{G}_i(x)| \leq y_i + \frac{y_i^2}{2(1 - y_i)^2} + \sum_{j \in V_i} \frac{x_j y_j^2}{2(1 - y_j)^2}.$$

The required bound follows now from the facts that

$$y_j \leq 1/x_i, \quad x_j y_j \leq 1 \quad \text{and} \quad y_j \leq 1/2$$

for all $j \in V_i$. □

Assume now that $t = 0$ (result for arbitrary t follows from the self-similarity of fluid limits). Let $x = z(0)$. Suppose that $s < x_i$. Let $k \leq |x^n|s$, then $W_i^{x^n}(k) \geq x_i^n - k \geq |x^n|(x_i^n/|x^n| - s)$. Hence, $W_i^{x^n}(k) \geq 2$ for $k \leq |x^n|s$ for large enough n .

We need to show that $\lim_{s \rightarrow 0} \frac{z_i(s) - z_i(0)}{s} = \lambda - \tilde{G}_i(z(0))$. Consider the following expression:

$$\begin{aligned} X_i^n(s) - X_i^n(0) &= \frac{1}{|x^n|} \sum_{k=0}^{\lfloor |x^n|s \rfloor - 1} (W_i^{x^n}(k+1) - W_i^{x^n}(k)) \\ &= \frac{1}{|x^n|} \sum_{k=0}^{\lfloor |x^n|s \rfloor - 1} E \left[W_i^{x^n}(k+1) - W_i^{x^n}(k) | W^{x^n}(k) \right] \\ &\quad + \frac{1}{|x^n|} \sum_{k=0}^{\lfloor |x^n|s \rfloor - 1} (W_i^{x^n}(k+1) - E[W_i^{x^n}(k+1) | W_i^{x^n}(k)]) \\ &= \frac{1}{|x^n|} \sum_{k=0}^{\lfloor |x^n|s \rfloor - 1} (\lambda - G_i(W^{x^n}(k))) + \frac{1}{|x^n|} \sum_{k=1}^{\lfloor |x^n|s \rfloor} D_k^n, \end{aligned} \quad (5.5)$$

where

$$D_k^n = W_i^{x^n}(k) - E(W_i^{x^n}(k) | W^{x^n}(k-1)) = A_i(k) - \lambda + q_i(k) - E(q_i(k) | W^{x^n}(k-1))$$

where $q_i(k) = I(N_i(k-1) = 1) \prod_{j \in V_i \setminus \{i\}} I(N_j(k-1) = 0)$. We have $\frac{1}{|x^n|} \sum_{k=1}^{\lfloor |x^n|s \rfloor} (A_i(k) - \lambda) \rightarrow 0$ a.s. when $n \rightarrow \infty$ and we can use Theorem VII.3 of Feller [62] (applied to $b_k = 1/k$) to deduce that almost surely

$$\frac{1}{|x^n|} \sum_{k=1}^{\lfloor |x^n|s \rfloor} (q_i(k) - E(q_i(k)|W^{x^n}(k-1))) \rightarrow 0 \quad (5.6)$$

as $n \rightarrow \infty$.

It remains to find the limit of the first term in Equation (5.5). We decompose this term as follows:

$$\frac{1}{|x^n|} \sum_{k=0}^{\lfloor |x^n|s \rfloor - 1} (\lambda - G_i(W^{x^n}(k))) = \frac{1}{|x^n|} \sum_{k=0}^{\lfloor |x^n|s \rfloor - 1} \left(\lambda - \tilde{G}_i \left(X^n \left(\frac{k}{|x^n|} \right) \right) \right) + \epsilon(t, n),$$

where by Lemma 5.2.9

$$|\epsilon(t, n)| \leq C \frac{1}{|x^n|} \sum_{k=0}^{\lfloor |x^n|s \rfloor - 1} \frac{1}{W_i^{x^n}(k)} \leq C \frac{1}{|x^n|} \sum_{k=0}^{\lfloor |x^n|s \rfloor - 1} \frac{1}{x_i^n - k} \rightarrow 0$$

as $n \rightarrow \infty$ uniformly in $s \leq x_i$. Further, from the uniform convergence of X^n to z and the continuity of \tilde{G} we deduce that

$$\frac{z_i(s) - z_i(0)}{s} = \lambda - \lim_{n \rightarrow \infty} \frac{\sum_{k=0}^{\lfloor |x^n|s \rfloor - 1} \tilde{G}_i \left(z \left(\frac{k}{|x^n|} \right) \right)}{|x^n|s}.$$

Since $\frac{1}{|x^n|} \sum_{k=1}^{\lfloor |x^n|s \rfloor} \tilde{G}_i(z(\frac{k-1}{|x^n|}))$ is a Riemann sum of a continuous bounded function, it converges to $\int_0^s \tilde{G}_i(z(u)) du$ and we have

$$\lim_{s \rightarrow 0} \frac{z_i(s) - z_i(0)}{s} = \lambda - \lim_{s \rightarrow 0} \frac{\int_0^s \tilde{G}_i(z(u)) du}{s} = \lambda - \tilde{G}_i(z(0)). \quad (5.7)$$

(ii) it remains to treat the case: $z_i(0) = 0$ and $\sum_{j \in V_i} z_j(0) > 0$. Notice that $\tilde{G}_i(z_i(0)) = 0$. In view of Equations (5.5) and (5.6) it suffices to show that:

$$\lim_{s \rightarrow 0^+} \lim_{n \rightarrow \infty} \frac{1}{|x^n|s} \sum_{k=0}^{\lfloor |x^n|s \rfloor - 1} G_i(W^{x^n}(k)) = 0. \quad (5.8)$$

By assumption, there exists $j \in V_i$ such that $z_j(0) = \lim_{n \rightarrow \infty} x_j^n / |x^n| > \alpha > 0$. Let $\epsilon > 0$, in particular there exists n_0 such that for all $n \geq n_0$, $x_j^n / |x^n| > \alpha$ and $x_i^n / |x^n| < \epsilon$.

Let $n \geq n_0$, pick $0 < s < \alpha$ and fix $\epsilon < \alpha$, then for n large enough, $W_i^{x^n}(k) \leq \epsilon |x^n| + A_i(0, k)$, $W_j^{x^n}(k) \geq \alpha |x^n| - k$ and:

$$\begin{aligned} G_i(W^{x^n}(k)) &\leq \frac{W_i^{x^n}(k)}{W_i^{x^n}(k) + W_j^{x^n}(k)} \\ &\leq \frac{\epsilon |x^n| + A_i(0, k)}{(\alpha + \epsilon) |x^n| - k} \end{aligned}$$

By the strong law of large numbers, a.s. $\lim_{t \rightarrow +\infty} A_i(0, t)/t = \lambda$. Let $\lambda_1 > \lambda$, we deduce that a.s. we may find k_0 such that for $k_0 \leq k \leq s|x^n|$ (we may suppose $|x^n|$ large enough to be larger than k_0/s):

$$G_i(W^{x^n}(k)) \leq \frac{\epsilon|x^n| + \lambda_1 k}{(\alpha + \epsilon)|x^n| - k},$$

and

$$\frac{1}{|x^n|} \sum_{k=0}^{\lfloor |x^n|s \rfloor - 1} G_i(W^{x^n}(k)) \leq \frac{k_0}{|x^n|} + \frac{\epsilon}{\alpha + \epsilon - s} + \frac{1}{|x^n|} \sum_{k=0}^{\lfloor |x^n|s \rfloor - 1} \frac{k\lambda_1}{\alpha|x^n| - k}$$

A direct computation shows that:

$$\lim_{n \rightarrow \infty} \frac{1}{|x^n|} \sum_{k=0}^{\lfloor |x^n|s \rfloor - 1} \frac{k\lambda_1}{\alpha|x^n| - k} = -\lambda_1(s + \alpha \ln(1 - \frac{s}{\alpha})).$$

We obtain, almost surely:

$$\limsup_n \frac{1}{|x^n|} \sum_{k=0}^{\lfloor |x^n|s \rfloor - 1} G_i(W^{x^n}(k)) \leq \frac{\epsilon}{\alpha + \epsilon - s} - \lambda_1(s + \alpha \ln(1 - \frac{s}{\alpha}))$$

Since this last inequality holds for all $\epsilon > 0$ and $\lambda_1 > \lambda$, we have:

$$\limsup_n \frac{1}{|x^n|} \sum_{k=0}^{\lfloor |x^n|s \rfloor - 1} G_i(W^{x^n}(k)) \leq -\lambda(s + \alpha \ln(1 - \frac{s}{\alpha})).$$

It then follows immediately that:

$$\lim_{s \rightarrow 0^+} \limsup_n \frac{1}{|x^n|s} \sum_{k=0}^{\lfloor |x^n|s \rfloor - 1} G_i(W^{x^n}(k)) = 0.$$

□

5.3 Properties of the Fluid Limit on the Boundary

Conjecture 5.3.1 *We think that any fluid limit z has a right-derivative at point 0 in all coordinates for any vector $z(0)$ (even if there exists i such that $x_j = z_j(0) = 0$ for all $j \in V_i$). We also believe that $z'(0)$ does not depend on the sequence x^n and depends only on $x = \lim_n x^n/|x^n|$. If it is so then all fluid limits are deterministic functions.*

In this Section, we will prove a weaker statement that we will be sufficient to prove that the boundary of the positive orthant does not play any role in the stability of the fluid model. Denote

$$\tau_h = \inf\{t \geq 0 : |z(t)| < h\}.$$

Assume that $|z(0)| = 1$ then $\max_i z_i(0) \geq 1/K$. The fact that $z'_i(t) \geq \lambda - 1$ for all i and t implies also that

$$\tau_{1-\epsilon} \geq \frac{\epsilon}{K(1-\lambda)}. \quad (5.9)$$

Theorem 5.3.2 *Assume that $|z(0)| = 1$. Then there exist positive constants b and ϵ_0 such that for any $\epsilon \in (0, \epsilon_0)$, $\min_i z_i(t) \geq b\epsilon$ for any $t \in [c\epsilon, \tau_{1-\epsilon}]$ where $c = 1/K(1-\lambda)$.*

The following corollary is immediate:

Corollary 5.3.3 *For any $0 < \varepsilon < 1$, $z_i(t) > 0$ for all $0 < t < \tau_{1-\varepsilon}$.*

The forthcoming Lemma 5.6.1 and Corollary 5.3.3 imply:

Corollary 5.3.4 *Assume that $|z(0)| > 0$, then either:*

- *there exists c such that $z(c) = 0$ and $z(t)$ remains in H for all $t \in (0, c)$ or,*
- *$z(t)$ remains in H for all $t > 0$.*

In particular when $z_i(0) = 0$, then Corollary 5.3.3 implies that the accumulation points of $\{\frac{z_i(t) - z_i(0)}{t}\}$ as t tends to 0^+ are included in $[b, \lambda]$.

The rest of this paragraph is devoted to the proof of Theorem 5.3.2. We first begin by some technical lemmas.

Lemma 5.3.5 *There exist positive constants $K_1 > 1$ and K_2 such that, for any fluid limit z , if $z_i(t) > K_1 z_j(t)$ for two neighboring nodes i and j then $z'_j(t) > K_2$.*

Proof of Lemma 5.3.5

Note that existence of $z'_j(t)$ is guaranteed by Theorem 5.2.8. Indeed $z_i(t) > 0$ and therefore $\sum_{k \in V_j} z_k(t) > 0$. To prove Lemma 5.3.5, note that

$$z'_j(t) > \lambda - \frac{z_j(t)}{\sum_{k \in V_j} z_k(t)} \geq \lambda - \frac{z_j(t)}{z_i(t) + z_j(t)} > \lambda - \frac{1}{1 + K_1}$$

and we may take $K_1 = 2/\lambda - 1$ and $K_2 = \lambda/2$. □

Lemma 5.3.6 *There exist constants $C_1 \geq C_2 > 0$ such that for any $h > 0$ if $|z(0)| \geq h_1$ and $\min_i z_i(0) \geq C_1 h$ then $\min_i z_i(t) \geq C_2 h_1$ for all $t \leq \tau_h$.*

Proof of Lemma 5.3.6

Let D be the maximal graph distance of \mathcal{G} . Put $C_1 = \frac{1}{KK_1^{D+1}}$ and put $C_2 = \frac{C_1}{K_1^{D-1}}$. We may prove Lemma 5.3.6 for $h = 1$. The result for arbitrary h follows from the self-similarity of fluid limits.

It is enough to show that for any $t < \tau_1$ if $\min_i z_i(t) \geq C_1$ then there exists $0 < s < \infty$ such that

$$\min_i z_i(t + s) \geq C_1 \tag{5.10}$$

and

$$\min_i z_i(u) \geq C_2 \quad \text{for all } t \leq u \leq t + s. \tag{5.11}$$

Indeed, assume that the last statement holds and Lemma 5.3.6 is not valid. Then there exists $t \leq \tau_1$ such that $\min_i z_i(t) < C_2$. It follows from the continuity of fluid limit that there exists the last moment $v < t$ when $\min_i z_i(v) \geq C_1$. However, our last statement implies that there exists $s > 0$ such that $\min_i z_i(v + s) \geq C_1$ and $\min_i z_i(u) \geq C_2$ for all $v \leq u \leq v + s$. Clearly, $v + s < t$ that contradicts our assumption on v being the last moment before t when $\min_i z_i(v) \geq C_1$.

Let now t be any time such that $t < \tau_1$ and $\min_i z_i(t) \geq C_1$. Note that $\max_i z_i(t) \geq 1/N = C_1 K_1^{D+1}$ since $t < \tau_1$. To simplify notation, assume that $z_1(t) = \max_i z_i(t)$. Let T be such that $z_1(t + u) \geq C_1 K_1^D$ for all $0 \leq u \leq T$. Note that $z'_i(u) \geq \lambda - 1$ for all i and u . This implies that

$$T \geq \frac{C_1(K_1^{D+1} - K_1^D)}{1 - \lambda} = \frac{C_1 K_1^D (K_1 - 1)}{1 - \lambda}. \tag{5.12}$$

Let now d be the maximal distance in \mathcal{G} from node 1. Clearly, $d \leq D$. For $j = 1, \dots, d$, denote by A_j the set of nodes at distance j from node 1.

We show that there exists $0 < s < T$ such that (5.10) and (5.11) hold. First, we show that $\min z_i(u) \geq C_2$ for all $t \leq u \leq t + T$. Note that $z_i(u) \geq C_1$ for all $i \in A_1$ and $t \leq u < t + T$. Indeed, assume that there exists $i \in A_1$ and $t \leq u < t + T$ such that $z_i(u) < C_1$. Then, by continuity, there exists last moment $t \leq u_1 < u$ such that $z_i(u_1) \geq C_1$. Lemma 5.3.5 implies that $z'_i(u_1) \geq K_2 > 0$ and hence, there exists time $u_2 > u_1$ such that $z_i(u_2) \geq C_1$ that contradicts our assumption on u_1 . Using induction and following the same arguments we can show that $z_i(u) \geq C_1/K_1^{j-1}$ for all $i \in A_j$ and $t \leq u \leq t + T$ for any $j = 1, \dots, d$. Hence, $\min_i z_i(u) \geq C_1/K_1^{d-1} \geq C_1/K_1^{D-1} = C_2$ for all $t \leq u \leq t + T$.

Let us now show that there exists $0 < s < T$ such that (5.10) holds. For every $j = 1, \dots, d$, denote by t_j time needed to achieve level $C_1 K_1^{d-j}$ starting from the level C_1/K_1^{j-1} and moving with the speed K_2 . Clearly, $t_j = \frac{C_1(K_1^{d-1} - 1)}{K_2 K_1^{j-1}}$. Note that (5.10) and (5.11) hold with $s = \sum_{j=1}^d t_j$

if $T \geq \sum_{j=1}^d t_j$. Indeed, $\min_{j \in A_1} z_j$ will achieve level $C_1 K_1^{d-1}$ not later than at the moment $t + t_1$ and will not become smaller than this level before time $t + T$, since all nodes in A_1 are neighbors of node 1 and $z_1(u) \geq K_1^D$ for all $t \leq u \leq t + T$. Note also that $\min_{j \in A_2} z_j$ will become greater than $C_1 K_1^{d-2}$ not later than at the moment $t + t_1 + t_2$ since it can not become smaller than C_1/K_1 before time $t + t_1$ and after this time it either is greater than $C_1 K_1^{d-2}$ or grows with the speed at least K_2 (this follows from Lemma 5.3.5 and the fact that any node in A_2 has a neighbor in A_1). We can continue these arguments to prove that $\min_{j \in A_d} z_j$ will become greater than C_1 at the moment not later than $t + \sum_{i=1}^d t_i$ if $T \geq \sum_{i=1}^d t_i$.

Note that

$$\begin{aligned} \sum_{i=1}^d t_i &= \frac{C_1(K_1^{d-1} - 1)(1 + K_1 + \dots + K_1^{d-1})}{K_2 K_1^{d-1}} = \frac{C_1(K_1^{d-1} - 1)(K_1^d - 1)}{K_2 K_1^{d-1}(K_1 - 1)} \\ &\leq \frac{C_1(K_1^d - 1)}{K_2(K_1 - 1)} \leq \frac{C_1(K_1^D - 1)}{K_2(K_1 - 1)} \end{aligned} \quad (5.13)$$

If we take $K_2 = \lambda/2$ and $K_1 = 2/\lambda - 1$ then $(1 - \lambda)/K_2 = K_1 - 1$. Note also that in this case $K_1 \geq 2$. It now follows from (5.12) and (5.13) that $T \geq \sum_{i=1}^d t_i$. □

One can see from the proof of Lemma 5.3.6 that the following (stronger) result holds.

Lemma 5.3.7 *For any $h_1 > 0$ there exists $\widehat{h}_2 > 0$ such that for any $h_2 \leq \widehat{h}_2$ there exists $0 < h_3 \leq h_2$ such that if $|z(0)| \geq h_1$ and $\min_i z_i(0) \geq h_2$ then $\min_i z_i(t) \geq h_3$ for all $t \leq \tau_{h_1}$.*

Remark 5.3.8 *Lemma 5.3.7 is valid with $\widehat{h}_2 = \frac{h_1}{K K_1^{D+1}}$.*

Proof of Theorem 5.3.2

The proof of Theorem 5.3.2 is similar to that of Lemma 5.3.6.

Take ϵ_0 such that $\frac{K_2(K_1 - 1)\epsilon}{(K_1^D - 1)} \leq \frac{1 - \epsilon}{K K_1^{D+1}}$ for all $\epsilon \leq \epsilon_0$ and take $a = \frac{K_2(K_1 - 1)}{(K_1^D - 1)}$. In this case, $a\epsilon \leq \frac{1 - \epsilon}{K K_1^{D+1}}$ and in view of Lemma 5.3.7 and Remark 5.3.8, it is enough to prove that $\min_i z_i(c\epsilon) \geq a\epsilon$.

Let D be the graph distance of \mathcal{G} . Note that $\max_i z_i(0) \geq 1/K$. Assume that $z_1(0) = \max_i z_i(0)$.

Let T be such that $z_1(u) \geq a\epsilon K_1^D$ for all $0 \leq u \leq T$. Note that $z'_i(t) \geq \lambda - 1$ for all i and t . This implies that

$$T \geq \frac{1/K - a\epsilon K_1^D}{1 - \lambda} = \frac{1 - Ka\epsilon K_1^D}{K(1 - \lambda)}. \quad (5.14)$$

Let now d be the maximal distance in \mathcal{G} from node 1. Clearly, $d \leq D$. For $j = 1, \dots, d$, denote by A_j the set of nodes at distance j from node 1. For every $j = 1, \dots, d$, denote by t_j time needed to achieve level $a\epsilon K_1^{d-j}$ starting from the level 0 and moving with the speed K_2 . Clearly, $t_j = \frac{a\epsilon K_1^{d-j}}{K_2}$. Denote $T_1 = \sum_{j=1}^d t_j$. Note that

$$T_1 = \frac{a\epsilon(K_1^D - 1)}{K_2(K_1 - 1)} = \frac{\epsilon}{K(1 - \lambda)} = c\epsilon. \quad (5.15)$$

Following the same arguments as in the proof of Lemma 5.3.6, we can show that $\min_i z_i(c\epsilon) = \min_i z_i(T_1) \geq a\epsilon$ if $T_1 \leq T$.

It remains to prove that $T_1 \leq T$. This is so due to (5.14), (5.15) and the fact that $a\epsilon \leq \frac{1 - \epsilon}{KK_1^{D+1}}$.

Remark 5.3.9 Denote by $\nu(z, h, b) = \inf\{t \geq z : |z(t)| < h \text{ or } \min_i z_i(t) < b\}$ the time (after moment z) of the first exit from the set $\{|z| \geq h\} \cap \{\min_i z_i \geq b\}$. Theorem 5.3.2 implies that there exist $b > 0$ and $z \geq 0$ such that $\tau_{1-\epsilon} = \nu(z\epsilon, 1 - \epsilon, b\epsilon)$ for any initial condition $z(0)$ with $|z(0)| = 1$.

5.4 Proof of Theorem 5.1.1

In this Section we present the proof of our main result. We start with the proof of stability. Due to Theorem 5.2.7 it is enough to prove that there exists a deterministic time t_0 such that for all fluid limits z satisfying $|z(0)| = 1$, $z(t) = 0$ for $t \geq t_0$ a.s.

Lemma 5.4.1 *If $z_i(t) > 0$ for all $i = 1, \dots, K$ then*

$$\left(\sum_i z_i^2(t) \right)' \leq \left(\lambda - \frac{e^{-1}}{V} \right) \sum_i z_i(t)$$

and hence, if $\lambda < \frac{e^{-1}}{V}$,

$$\left(\sum_i z_i^2(t) \right)' \leq -\epsilon \sum_i z_i(t)$$

for some $\epsilon > 0$.

Proof of Lemma 5.4.1.

Clearly, it is sufficient to prove the following inequality

$$\frac{\sum_i z_i \varphi_i \exp \left\{ - \sum_{j \in V_i} \varphi_j \right\}}{\sum_k z_k} \geq \frac{e^{-1}}{V} \quad (5.16)$$

where we slightly abuse notation by writing z_i instead of $z_i(t)$. We can write the LHS of the previous inequality in the following form:

$$\sum_i p_i f(y_i)$$

where $p_i = \frac{z_i}{\sum_k z_k}$, $y_i = -\sum_{j \in V_i} \varphi_j - \ln \frac{1}{\varphi_i}$ and $f(z) = e^z$. Function f is convex and $\sum_i p_i = 1$, hence, $\sum_i p_i f(y_i) \geq f(\sum_i p_i y_i)$ and

$$\frac{\sum_i z_i \varphi_i \exp \left\{ -\sum_{j \in V_i} \varphi_j \right\}}{\sum_k z_k} \geq \exp \left\{ -\sum_i \frac{z_i}{\sum_k z_k} \sum_{j \in V_i} \varphi_j - \sum_i \frac{z_i}{\sum_k z_k} \ln \frac{1}{\varphi_i} \right\}. \quad (5.17)$$

Consider now $\sum_i \frac{z_i}{\sum_k z_k} \sum_{j \in V_i} \varphi_j$ and $\sum_i \frac{z_i}{\sum_k z_k} \ln \frac{1}{\varphi_i}$ separately:

$$\sum_i \frac{z_i}{\sum_k z_k} \sum_{j \in V_i} \varphi_j = \frac{\sum_i z_i \sum_{j \in V_i} \varphi_j}{\sum_k z_k} = \frac{\sum_j \varphi_j \sum_{i \in V_j} z_i}{\sum_k z_k} = \frac{\sum_j z_j}{\sum_k z_k} = 1. \quad (5.18)$$

(we used the facts that $j \in V_i$ if and only if $i \in V_j$ and that $\varphi_j \sum_{i \in V_j} z_i = z_j$.)

Note that the function \ln is concave, hence,

$$\sum_i \frac{z_i}{\sum_k z_k} \ln \frac{1}{\varphi_i} \leq \ln \left(\sum_i \frac{z_i}{\sum_k z_k} \frac{1}{\varphi_i} \right) = \ln \left(\frac{\sum_i \frac{z_i}{\varphi_i}}{\sum_k z_k} \right) = \ln \left(\frac{\sum_i \sum_{j \in V_i} z_j}{\sum_k z_k} \right) = \ln V. \quad (5.19)$$

Inequality (5.16) follows now from (5.17), (5.18) and (5.19). □

Proof of Theorem 5.1.1.

Corollary 5.3.3 implies that if $|z(0)| = 1$ then $z_i(t) > 0$ for all $i = 1, \dots, K$ and all $t > 0$. Then we can use Lemma 5.4.1. Note also that for any positive values of $\{x_i\}$ it holds that $\sum_i x_i \geq \sqrt{\sum_i x_i^2}$. Hence, Lemma 5.4.1 implies that

$$\left(\sum_i z_i^2(t) \right)' \leq -\varepsilon \sqrt{\sum_i z_i^2(t)}$$

and hence,

$$\left(\sqrt{\sum_i z_i^2(t)} \right)' \leq -\varepsilon/2$$

and the result follows. □

5.5 Rates of Convergence

In this section, we obtain rates of convergence of W_n to its stationary distribution in the total variation norm. Define the total variation distance between measures π_1 and π_2 by

$$\|\pi_1(\cdot) - \pi_2(\cdot)\| = \sup_{|g| \leq 1} \left| \int g(y)\pi_1(dy) - \int g(y)\pi_2(dy) \right|.$$

Theorem 5.5.1 *Assume that $\lambda < e^{-1}/V$ and $EA_i(n)^{p+1} < \infty$ for some $p \geq 1$ and for all $i = 1, \dots, K$ and n . Then*

$$\lim_{n \rightarrow \infty} n^p \|\mathbf{P}^n(x, \cdot) - \pi(\cdot)\| = 0, \quad x \in \mathbb{N}^K,$$

where $\mathbf{P}^n(x, \cdot)$ — distribution of $W^x(n)$ and $\pi(\cdot)$ — stationary measure for W .

Proof of Theorem 5.5.1

The proof of Theorem 5.5.1 is based on the following lemma which is an analogue of Proposition 5.3 of Dai and Meyn [54].

Lemma 5.5.2 *Assume that the conditions of Theorem 5.5.1 are satisfied. Then for some constants $c < \infty$, $\delta > 0$ and a finite set C ,*

$$E \left(\sum_{n=0}^{\tau_C(\delta)} |W^x(n)|^p \right) \leq c|x|^{p+1}$$

for any $x \in \mathbb{N}^K$, where $\tau_C(\delta) = \min(n \geq \delta : W(n) \in C)$.

Proof of Lemma 5.5.2

The proof of Lemma 5.5.2 follows the lines of proof of Proposition 5.3 of [54].

It follows from Theorem 5.2.7 that there exists t_0 such that

$$\lim_{|x| \rightarrow \infty} \frac{W^x(|x|t_0)}{|x|} = 0$$

a.s. Note also that the family of random variables $\left\{ \frac{|W^x(|x|t_0)|^{p+1}}{|x|^{p+1}} \right\}$ is uniformly integrable since

$$\frac{|W^x(|x|t_0)|^{p+1}}{|x|^{p+1}} \leq \frac{\left(\sum_{m=0}^{|x|t_0} \sum_{i=1}^K A_i(m) \right)^{p+1}}{|x|^{p+1}} \leq t_0^{p+1} \frac{\sum_{m=0}^{|x|t_0} \left(\sum_{i=1}^K A_i(m) \right)^{p+1}}{|x|t_0}$$

and the family $\left\{ \frac{\sum_{m=0}^{|x|t_0} \left(\sum_{i=1}^K A_i(m) \right)^{p+1}}{|x|t_0} \right\}$ is uniformly integrable. The latter is guaranteed by the existence of $EA_i(m)^{p+1}$ for all $i = 1, \dots, K$ and for all m . Hence,

$$\lim_{|x| \rightarrow \infty} \frac{E [|W^x(|x|t_0)|^{p+1}]}{|x|^{p+1}} = 0.$$

Choose L such that

$$E [|W^x(|x|t_0)|^{p+1}] \leq \frac{1}{2}|x|^{p+1} \tag{5.20}$$

for $|x| \geq L$. Define as in the proof of Proposition 5.3 of [54], the sequence of stopping times $\sigma_0 = 0, \sigma_1 = t(x)$, and $\sigma_{k+1} = \sigma_k + \theta_{\sigma_k} \sigma_1, k \geq 1$, where $t(x) = t_0 \max(L, |x|)$, θ — shift operator on the sample space. We assume that t_0 is an integer. The stochastic process $\hat{W}_k = W(\sigma_k)$ is a Markov chain with transition kernel

$$\hat{P}(x, A) = \mathbf{P}(W^x(t(x)) \in A).$$

Now (5.20) implies that

$$E \left\{ |\hat{W}_1|^{p+1} - |\hat{W}_0|^{p+1} | \hat{W}_0 = x \right\} \leq -\frac{1}{2} |x|^{p+1} + b \mathbf{I}_C(x),$$

where set $C = \{x : |x| \leq L\}$ and b is some constant. The Comparison Theorem (Meyn and Tweedie [123], p. 337) yields that

$$E \left[\sum_{n=0}^{k_*-1} |W^x(\sigma_k)|^{p+1} \right] = E \left[\sum_{n=0}^{k_*-1} |\hat{W}(k)|^{p+1} \right] \leq 2 \{ |x|^{p+1} + b \mathbf{I}_C(x) \} \quad (5.21)$$

where $k_* = \min(k \geq 1 : \hat{W}(k) \in C)$. To prove Lemma 5.5.2, we first show that for some constant c_0 ,

$$E \left[\sum_{n=\sigma_k}^{\sigma_{k+1}} |W^x(n)|^p | \mathcal{F}_{\sigma_k} \right] \leq c_0 |W^x(\sigma_k)|^{p+1} \quad (5.22)$$

which by the strong Markov property amounts to

$$E \sum_{n=0}^{t(x)} |W^x(n)|^p \leq c_0 |x|^{p+1}$$

This follows from the fact that

$$\sum_{n=0}^{t(x)} |W^x(n)|^p \leq \sum_{n=0}^{t(x)} \left(\sum_{m=0}^n \sum_{i=1}^K A_i(m) \right)^p \leq \sum_{n=0}^{t(x)} \left(\sum_{m=0}^{t(x)} \sum_{i=1}^K A_i(m) \right)^p$$

a.s. and from our assumption that $E A_i(m) < \infty$ for all $i = 1, \dots, K$ and for all m . Substituting (5.22) into (5.21), we have

$$E \left[\sum_{k=0}^{\infty} E \left[\sum_{n=\sigma_k}^{\sigma_{k+1}} |W^x(n)|^p | \mathcal{F}_{\sigma_k} \right] \mathbf{I}_{k < k_*} \right] \leq c |x|^{p+1}.$$

By Fubini's theorem and the smoothing property of the conditional expectation, the LHS is precisely $E \left[\sum_{n=0}^{\sigma_{k_*}} (1 + |W^x(n)|^p) \right]$. The proposition now follows from the fact that $\sigma_{k_*} \geq \tau_C(t_0 L)$. □

We now use Proposition 5.4 of [54] with $t = 1$. Applied to our case, it gives the following bound:

$$E \{ V(W(1)) - V(W(0)) | W(0) = x \} \leq -f(x) + \kappa \quad (5.23)$$

with $V(x) = E \left(\sum_{n=0}^{\tau_C(\delta)} |W^x(n)|^p \right)$ and $f(x) = |x|^p$.

Note that Lemma 5.5.2 implies that $V(x) \leq c |x|^{p+1}$. Now (5.23) yields that

$$E \{ V(W(1)) - V(W(0)) | W(0) = x \} \leq V(x)^{\frac{p}{p+1}} + b \mathbf{I}_C$$

for the set $C = \{x : |x| \leq L\}$ and for some constant b . The result now follows from Theorem 2.5 of Douc et al. [58]. □

5.6 Local Stability of Fluid Limits on the positive Orthant

In this Section we investigate the behaviour of the solution to the differential equation satisfied by fluid limits. In particular, we show that if input rate λ is sufficiently small then the diagonal is locally unstable.

5.6.1 Orbits of the fluid limits

Denote $H = \{x \in \mathbb{R}^K : x_i > 0 \text{ for all } i = 1, \dots, K\}$ and $\mathbf{1} = (1, \dots, 1)'$. For $z(t)$ in H , the Differential Equation (5.3) is restated in close form as:

$$\dot{z}(t) = F(\phi(z(t))), \quad (5.24)$$

with $F(x)_i = \lambda - x_i e^{-\sum_{j \in V_i} x_j}$. Let $\Delta = \{x \in H : x_1 = x_2 = \dots = x_K\}$ and $C_u = \{x \in H : |x/|x| - \mathbf{1}/K| \leq u\}$, $u > 0$, C_u is a cone with direction Δ . We note that the diagonal is an orbit of the differential equation: $F(\phi(c\mathbf{1})) = (\lambda - e^{-1}/V)\mathbf{1}$. We are going to prove that the diagonal is also locally attractive.

Lemma 5.6.1 *Assume that $|z(0)| \in H$, then either:*

- there exists c such that $z(c) = 0$ and $z(t)$ remains in H for all $t \in (0, c)$ or,
- $z(t)$ remains in H for all $t > 0$.

Proof of Lemma 5.6.1.

Restricted on the open set H , $F \circ \phi$ is $\mathcal{C}^\infty(\mathbb{R}^n)$. Therefore, the solutions of Equation (5.24) are locally uniquely defined as long as $z(t)$ remains in H . Now, suppose on the contrary that $t \mapsto z(t)$ leaves H at time c at $y = \lim_{t \rightarrow c^-} z(t) \in \partial H \setminus \{0\}$.

Let $a_i = \limsup_{t \rightarrow c^-} \phi(z(t))$, $a_i \in [0, 1]$. Since $y \neq 0$ there exists i_1 and i_2 such that $y_{i_1} = 0$ and $y_{i_2} > 0$. Note also that G is connected implies that there exists k such that $y_k = 0$ and $\sum_{j \in V_k} y_j > 0$ (consider the path from i_1 to i_2). Hence, $a_k = 0$ and $\lim_{t \rightarrow c^-} F_k(\phi(z(t))) = \lambda > 0$, this implies that $t \mapsto x_k(t)$ increases on a left neighborhood of c , this is contradictory with $y_k = \lim_{t \rightarrow c^-} z(t) = 0$. \square

Lemma 5.6.1 implies that for an initial condition in H , the fluid limit $z(t)$ remains in H or finally reaches 0 at time c . By convention, we set that $\phi(0) = \mathbf{1}/V$, thus after time c , the orbit of z remains on the diagonal: for $t \geq 0$, $z(t+c) = (\lambda - e^{-1}/V)\mathbf{1}t$. Notice also that if $x \in H$, then $F(\phi(z)) \leq \lambda\mathbf{1}$ (component wise). In view of Lemma 5.6.1 this immediately implies that if $z(0)$ is in H then the maximal solution of Equation (5.24) is defined on \mathbb{R}_+ . Lemma 5.6.1 also implies that if $z(0) = \lim_n x^n/|x^n| \in H$ then the fluid limit is deterministic.

Let A be the adjacency matrix of G and $\{\nu_1, \dots, \nu_K\}$ its eigenvalues with $\nu_i \leq \nu_{i+1}$. The spectral gap γ is defined by:

$$\gamma = \min_{i < K} (\nu_K - \nu_i) = \nu_K - \nu_{K-1}.$$

Note that since G is $V-1$ regular, $\nu_K = V$. The main result of this section is the following.

Theorem 5.6.2 *If $\lambda > \frac{e^{-1}}{V}(1 - \frac{\gamma^2}{V^2})$, there exists $u > 0$ such that for all solution $t \rightarrow z(t)$ of Equation (5.24) with initial condition in C_u ,*

$$\lim_{t \rightarrow +\infty} \phi(z(t)) = \mathbf{1}/V.$$

If $\lambda < \frac{e^{-1}}{V}(1 - \frac{\gamma^2}{V^2})$ the diagonal is locally unstable.

Corollary 5.6.3 *If $\lambda > \frac{e^{-1}}{V}(1 - \frac{\gamma^2}{V^2})$, there exists $u > 0$ such that if $z(t)$ is a solution of Equation (5.24) with an initial condition $z(0)$ in C_u ,*

- *if $\lambda < e^{-1}/V$, then there exists $c > 0$ such that, $z(c) = 0$.*
- *if $\lambda > e^{-1}/V$, then $z(t) \sim (\lambda - e^{-1}/V)t$.*

Proof of Corollary 5.6.3

Let $z(t)$ be the maximal solution with $z(0) \in H$. From Theorem 5.6.2, $\lim \phi(z(t)) = \mathbf{1}/V$. Since F is $C^\infty(\mathbb{R}^n)$ on a neighborhood of $\mathbf{1}/V$, $\lim_{t \rightarrow +\infty} \dot{z}(t) = (\lambda - e^{-1}/V)\mathbf{1}$. If $\lambda \neq e^{-1}/V$, this implies that, as t tends toward infinity:

$$z(t) \sim (\lambda - e^{-1}/V)t\mathbf{1}. \quad (5.25)$$

Suppose first that $\lambda - e^{-1}/V < 0$ then from Equation (5.25), $z(t)$ leaves H in finite time. Lemma 5.6.1 implies in turn that there exists $c > 0$ such that $z(c) = 0$. The first assertion of Corollary 5.6.3 is proved. \square

Remark 5.6.4 The first statement of Corollary 5.6.3 can be strengthened in the following way:

there exists $\delta > 0$ and $v > 0$ such that for all $z(0) \in C_v$, $z(\delta|z(0)|) = 0$.

Indeed, let δ such that $0 < \delta^{-1} < e^{-1}/V - \lambda$. There exist $\epsilon > 0$ such that for all i and $z \in C_\epsilon$, $\phi(z)_i < -\delta$. We then define $v = \min(u, \epsilon)$

5.6.2 Proof of Theorem 5.6.2

This theorem is an application of the stability theory for differential equations.

Spectral Analysis

We need to consider the eigenvalues of $D(F \circ \phi)(x)$, for $x \in \Delta$, where $Df(x)$ is the differential of f at x . $F \circ \phi$ is homogeneous of degree 0: for all $c > 0$, $F(\phi(cx)) = F(\phi(x))$. Hence:

$$D(F \circ \phi)(c\mathbf{1}) = c^{-1}D(F \circ \phi)(\mathbf{1}).$$

Since Δ is an orbit of Equation (5.24), $\mathbf{1}$ is an eigenvector of $D(F \circ \phi)(\mathbf{1})$ associated with the eigenvalue 0.

Lemma 5.6.5 *The eigenvalues of $D(F \circ \phi)(\mathbf{1})$ are $(0, \lambda_1, \dots, \lambda_{K-1})$ with $\lambda_i = -\frac{e^{-1}}{V^3}(V - \nu_{K-i})^2$. In particular, for all $i \geq 1$, $\lambda_i < 0$.*

Proof of Lemma 5.6.1 A direct computation leads to:

$$(D(F \circ \phi)(\mathbf{1}))_{ij} = \begin{cases} -\frac{e^{-1}(V-1)}{V^2} & \text{if } j = i \\ \frac{e^{-1}}{V^3}|V_i \cup V_j| & \text{if } j \in V_i \setminus i \\ -\frac{e^{-1}}{V^3}|V_i \cap V_j| & \text{if } j \notin V_i \end{cases}$$

Not surprisingly, $D(F \circ \phi)(\mathbf{1})\mathbf{1} = 0$. Indeed let $M = -eV^3D(F \circ \phi)(\mathbf{1})$, using the fact that $|V_i \cup V_j| = 2V - |V_i \cap V_j|$, we deduce that:

$$(M\mathbf{1})_i = V(V-1) - 2V(V-1) + \sum_{j \neq i} |V_i \cap V_j| = \sum_{j=1}^K |V_i \cap V_j| - V^2 = 0.$$

Let E denotes the identity matrix and A the adjacency matrix of \mathcal{G} , since $(A^2)_{ij} = |V_i \cap V_j|$, we have the following decomposition:

$$M = V^2E - 2VA + A^2 = (A - VE)^2.$$

A is irreducible by hypothesis (\mathcal{G} is connected), thus $(A - VE)$ is an ML-Matrix (refer to Seneta [142]). In graph theory, this matrix is referred as the Laplacian matrix of G . From Corollary 1 of Theorem 1 in Seneta [142], the spectral radius of A is V , Theorem 2.6 (d) of [142] implies that $\dim \text{Ker}(A - VE) = 1$ and all the eigenvalues of $(A - E)^2$ different from 0 are positive reals (remind that the spectrum of A is real). Lemma 5.6.5 is proved. \square

Orbit of $\psi \circ z$

We define:

$$\Sigma = \{x \in H : \sum_{i=1}^K x_i = 1\} = H \cap \langle \mathbf{1}, \cdot \rangle^{-1}(\{1\}) = \psi(H),$$

where $\psi(x) = x/|x|$. Σ is clearly a C^∞ -convex manifold of codimension 1. We define the following differential equation on Σ :

$$\dot{y} = D\psi(y)F(\phi(y)) = \alpha(y). \quad (5.26)$$

with an initial condition $y(0)$ in Σ . α is a $C^\infty(\Sigma)$ function and $\alpha(y) \in T_y(\Sigma)$ the tangent space of Σ at y . The next step is to compare the orbits of Equation (5.26) and Equation (5.24). The next lemma asserts that the orbits of the solution of $\dot{y} = \alpha(y)$ and $\psi \circ x$ where $t \mapsto z(t)$ is a solution of Equation (5.24) are indeed equal.

Lemma 5.6.6 *Let $z(0)$ in H and $z(t)$ the maximal solution of Equation (5.24). Let $y(t)$ be the maximal solution of $\dot{y} = G(y)$, with initial condition $y(0) = \psi(z(0))$, then it is defined on \mathbb{R}_+ and there exists an increasing continuous bijective function $\mu : \mathbb{R}_+ \rightarrow \mathbb{R}_+$ such that:*

$$y \circ \mu = \psi \circ z$$

Proof of Lemma 5.6.6.

This lemma is a classical result. For an initial condition in H , we have $F(z(t)) \leq \lambda \mathbf{1}$. Indeed, while $z(t) \in H$ it is clear. If $z(t) \notin H$, from Lemma 5.6.1, $z(t) \in \Delta \cap -\overline{H}$, thus $F(z(t)) = (\lambda - 1/Ve^{-1})\mathbf{1} \leq \lambda \mathbf{1}$. It follows that $|z(t)| = \sum_{j=1}^n z_j(t) \leq K\lambda t + \sum_{j=1}^n z_j(0)$.

Suppose now that for all t , $z(t) \in H$, then $\int_0^{+\infty} \frac{ds}{\sum_{j=1}^K z_j(s)}$ diverges. By the intermediate value theorem, we deduce that there exists an increasing continuous function ν such that:

$$\text{for all } t \geq 0, \quad \int_0^{\nu(t)} \frac{ds}{\sum_{j=1}^K z_j(s)} = t. \quad (5.27)$$

In particular:

$$\dot{\nu}(t) = \sum_{j=1}^K z_j(\nu(t)).$$

Let $w = \psi \circ z \circ \nu$, $w(0) = \psi(w(0)) = y(0)$. We have:

$$\begin{aligned} \dot{w}(t) &= \dot{\nu}(t) \frac{d}{ds} \psi(z(s)) \Big|_{s=\nu(t)} \\ &= \left(\sum_{j=1}^K z_j(\nu(t)) \right) D\psi(z(\nu(t))).F(w(t)). \end{aligned}$$

ψ is homogeneous of order 0 and thus for all $c > 0$, $D\psi(cz) = c^{-1}D\psi(z)$. It follows that:

$$\begin{aligned}\dot{w}(t) &= D\psi\left(\frac{z(\nu(t))}{\sum_{j=1}^n z_j(\nu(t))}\right) \cdot F(w(t)) \\ &= G(w(t)).\end{aligned}$$

The solution of the differential equation is unique, therefore $w(t) = y(t)$. The lemma is proved with $\mu = \nu^{-1}$.

If $z(t)$ leaves H , from Lemma 5.6.1, there exists c such that $z(c) = 0$ and $z(t) = (\lambda - e^{-1}/V)(t - c)\mathbf{1}$ for $t \geq c$. Then the mapping ν is build on $[0, c]$ as we did previously and for $t \geq c$, $\nu(t) = \nu(c) + t - c$. Then the same proof holds. \square

About the behaviour of μ , we have easily the following:

Lemma 5.6.7 *Let $\epsilon \geq 0$ and $\tau_\epsilon(z(0)) = \inf\{t : |z(t)| \leq \epsilon\}$, for all $0 \leq t \leq \tau_\epsilon(z(0))$,*

$$\frac{1}{K\lambda} \ln\left(\frac{K\lambda}{|z(0)|}t + 1\right) \leq \mu(t) \leq \frac{t}{\epsilon},$$

Proof of Lemma 5.6.7. We start with the lower bound, if $t \leq \tau_\epsilon(z(0))$ then, $\sum_{i=1}^n z_j(s) \geq \epsilon$ for all $s \in [0, t]$, hence, by Equation (5.27), we get $\nu(t)/\epsilon \geq t$, since $\nu = m\mu^{-1}$, we deduce the lower bound. Similarly, for the upper bound, we notice that, $\sum_{i=1}^n z_j(s) \leq |z(0)| + K\lambda s$, and by Equation (5.27) we get, $1/(K\lambda) \ln(K\lambda/|z(0)|\nu(t) + 1) \leq t$. \square

Local stability of $\psi \circ z$.

$y_0 = \mathbf{1}/K$ is an equilibrium point of Equation (5.26). In the next lemma we prove that this equilibrium is locally stable.

Lemma 5.6.8 *If $\lambda > \frac{e^{-1}}{V}(1 - \frac{\gamma^2}{V^2})$, there exists $u > 0$ such that for all solutions $t \mapsto y(t)$ of Equation (5.26) with $|y(0) - y_0| < u$,*

$$\lim_{t \rightarrow +\infty} \sup_{y(0) \in \Sigma: |y(0) - y_0| < u} |y(t) - \mathbf{1}/V| = 0.$$

Proof of Lemma 5.6.8.

We denote by $D\alpha(y)|_{T_y(\Sigma)}$, the differential of α at y restricted to the $K - 1$ dimensional subspace $T_y(\Sigma)$. We examine if all the eigenvalues of $D\alpha(y_0)|_{T_{y_0}(\Sigma)}$ have a negative real part, this will imply the local stability (refer for example to Coddington and Levinson [47]). If $D^2\psi(y)(\cdot, \cdot)$ denote the second differential of ψ at y , seen as a bilinear mapping. We have:

$$D\alpha(y) = D^2\psi(y)(F(\phi(y)), \cdot) + D\psi(y)D(F \circ \phi)(y). \quad (5.28)$$

The first term in this last equation is a matrix and its entry (i, j) is equal to:

$$\sum_{k=1}^K \frac{\partial^2 \psi(y)_i}{\partial y_j \partial y_k} F(\phi(y))_k.$$

For $y = y_0$, $F(\phi(y_0)) = (\lambda - e^{-1}/V)\mathbf{1}$, and a straightforward computation gives:

$$D^2\psi(y_0)(F(\phi(y_0)), \cdot) = (\lambda - e^{-1}/V)(J - KE),$$

where E is the identity matrix and J is the matrix with all its entries equal to 1. We also have $D\psi(y_0) = (KE - J)/K$. Finally, Equation (5.28) can be rewritten as:

$$D\alpha(y_0) = 1/K(KE - J) \left(D(F \circ \phi)(y_0) - (\lambda - e^{-1}/V)E \right).$$

$(KE - J)$ commutes with all symmetric matrices and $(KE - J)$ has two eigenvalues K (with multiplicity $K - 1$) and 0 (with multiplicity 1, associated to the eigenvector $\mathbf{1}$). By Lemma 5.6.5, the eigenvalues of $D(F \circ \phi)(y_0) - (\lambda - e^{-1}/V)E$ are

$$0 \leq i \leq K - 1 : \mu_i = -e^{-1}(V - \nu_{K-i})^2/V^3 - \lambda + e^{-1}/V.$$

The eigenvector associated to $\mu_0 = \lambda - e^{-1}/V$ is $\mathbf{1}$. Thus we have proved that $\lambda - e^{-1}/V$ is an eigenvalue of multiplicity 1 for $D\alpha(y_0)$ and that the other eigenvalues are $(\mu_i)_{i \geq 1}$. These eigenvalues have negative real parts if and only if $\mu_1 = -e^{-1}\gamma^2/V^3 - \lambda + e^{-1}/V < 0$, that is $\lambda > e^{-1}(1 - \gamma^2/V^2)/V$. The vector space generated by the associated eigenvectors is precisely the tangent hyperplane $T_{y_0}(\Sigma) = \mathbf{1}^\perp$, the hyperplane orthogonal to $\mathbf{1}$. \square

We can then prove Theorem 5.6.2. Let $|z(0)| \in C_u$ and $y(0) = z(0)/|z(0)|$, by Lemmas 5.6.6 and 5.6.8:

$$\lim_{t \rightarrow +\infty} \psi(z(t)) = \lim_{t \rightarrow +\infty} y(\mu(t)) = \mathbf{1}/K.$$

In particular, $\phi(z(t))$ tends toward $\mathbf{1}/V$ as t tends toward infinity.

Due to the continuity of $F \circ \phi$ and Lemma 5.6.7, we also obtain:

Lemma 5.6.9 *If $\lambda > e^{-1}/V$, then*

$$\lim_{t \rightarrow \infty} \sup_{z(0) \in \Sigma \cap C_u} |F(\phi(z(t))) - (\lambda - \frac{e^{-1}}{V})\mathbf{1}| = 0.$$

5.7 Extensions of the model

5.7.1 Random neighbourhood

In this Subsection we consider a possible extension of our model. Assume there is a fixed number of points $1, \dots, K$ and a set of non-directed graphs $\{\mathcal{G}^j\}_{j=1}^L$ each having points $1, \dots, K$ as its vertices. Assume that at each time n the neighbourhood relations are given by the graph \mathcal{G}^{η_n} where η_n are independent identically distributed random variables taking value j with probability p_j . The need to consider such a variability of neighbourhood relations may be justified by, for instance, the fact that a change of environment conditions may lead to a change of the radius and/or direction of interactions.

Denote by \mathcal{V}_i^j the neighbourhood of the point i in the graph \mathcal{G}^j and by V_i^j its cardinal. We assume that the system is in some sense "regular": $\mathbf{E}V_i^{\eta_1} = V$ for all i .

Following the proof of Theorem 5.2.8, one can show that fluid limits of the model described above satisfy the following differential equation

$$z_i'(t) = \lambda - \sum_{k=1}^L p_k \varphi_i^k(t) e^{-\sum_{j \in V_i^k} \varphi_j^k(t)}$$

where $\varphi_i^k(t)$ are defined in an obvious way. Using the same methods as those used in the proof of Theorem 5.1.1 it can be shown that the system with random neighbourhood is stable if $\lambda < \frac{e^{-1}}{V}$.

5.7.2 Non-regular graphs with space-inhomogeneous input

Assume now that $\mathbf{E}V_i^{\eta_1} = V_i$ and V_i are not necessarily equal. Put $V = \max_i V_i$. Assume also that $\mathbf{E}\xi_i^n = \lambda_i$ so that the input is "space-inhomogeneous". Put $\lambda = \max_i \lambda_i$. Clearly, all the results concerning fluid limits hold in this case too, and it is easy to see that one can prove the following result.

Theorem 5.7.1 *The system described above is stable provided $\lambda < \frac{e^{-1}}{V}$.*

5.7.3 Infinite Graph

We have supposed that the number of vertex K was finite, however since K does not appear in the stability condition e^{-1}/V , we believe that the same stability result on V -regular infinite graphs. The same remark holds for the following continuous model.

5.7.4 Continuous Model

Let \mathbb{T}^d be the unit torus of \mathbb{R}^{d+1} and fix an origin 0 in \mathbb{T}^d (the only reason we choose the torus and not any compact set of \mathbb{R}^d is to avoid any boundary effect). We consider a i.i.d. arrival process $A = (A_n)_{n \in \mathbb{N}}$ where A_n is a stationary point process on \mathbb{T}^d of intensity λ . The workload at time n , W_n , is now a.s. a locally finite atomic measure on \mathbb{T}^d , a user is an atom of W_n . For a Borel set B , $W_n(B)$ is the number of users in B at time n .

Let S be a symmetric open Borel set of \mathbb{T}^d : $y \in S$ implies $-y \in S$. S is the range of interactions between users, typically S is a ball of radius R and center 0. We suppose that the boundary of S has a finite $d - 1$ -Lebesgue measure.

For $x \in \mathbb{T}^d$ and a set B , we denote the Minkowski addition by $x + B = \{x + y, y \in B\}$. At each time slot, a user located at $x \in S$ emits independently of the others with probability $1/W_n(x + S)$. A user located at x leaves the system if and only if he is the only user emitting in $x + S$.

Let N_n be the counting measure of users emitting at time n . N_n is absolutely continuous with respect to W_n . For a Borel set B , $N_n(B)$ is the number of users emitting in B . We have the following relation

$$W_n = W_{n-1} + A_n - \int_{\mathbb{T}^d} \mathbf{1}(N_{n-1}(x + S) = 1) N_{n-1}(dx),$$

which is a continuous version of Equation (5.1). W is a Markov chain on the space \mathcal{M} of finite measures on \mathbb{T}^d , which a separable metric space. Markov chain theory is thus well defined on \mathcal{M} .

Let ν denote the d -dimensional Lebesgue measure. We can state the following conjecture:

Conjecture 5.7.2 *If $\lambda < e^{-1}/\nu(S)$ then W is Harris recurrent. If $\lambda > e^{-1}/\nu(S)$ then W is transient.*

This conjecture is an analog of the stability result on the discrete model.

5.7.5 Shot-noise Interaction

In the continuous model, another type of interaction worth to be mentioned and analyzed. Let N_n be the counting measure of users emitting at slot n , $r \mapsto l(r)$ be a nonincreasing positive

function, and $|\cdot|$ be the euclidean norm. In the shot-noise interaction model, an emitting user leaves the system if:

$$\int_{\mathbb{T}^d \setminus \{x\}} l(|x - y|) N_n(dy) \leq c.$$

Chapter 6

Stability of spatial queueing systems

Résumé Dans ce chapitre nous étudions un système de files d'attente dans lequel un processus spatio-temporel d'arrivée de clients est servi par un ensemble dénombrable de serveurs. Les clients ont des positions dans l'espace et les serveurs servent à des débits qui varient suivant la position. La charge est vue comme une mesure de Radon et les serveurs adaptent leur allocation de puissance en fonction de la charge actuelle. Nous établissons la région de stabilité de ce système de files d'attente sous les hypothèses usuelles d'ergodicité. L'étude de la région de stabilité fournit un résultat contre-intuitif sur l'impact de la coopération entre les serveurs. Deux sous-classes de politiques d'allocation sont également étudiées : les *politiques monotones* qui préservent une relation d'ordre naturelle pour la charge et les *politiques cellulaires* où l'espace est partagé entre les serveurs. Le domaine des réseaux de communication sans-fils est une application naturelle de ce modèle.

Abstract In this chapter, we analyze a queueing system that is characterized by a space-time arrival process of customers who are served by a countable set of servers. Customers arrive at points in space, and the server stations have space-dependent processing rates. The workload is seen as a Radon measure, and the server stations adapt their power allocation with the current workload. We derive the stability region of the queueing system in the usual stationary ergodic framework. The analysis of this stability region gives a counter-intuitive result on the impact of cooperation between server stations. Two subclasses of policies are also studied: *monotone policies* which preserve a natural ordering of the workload, and *cellular policies* where the space is divided among the server stations. The field of wireless communication networks is a natural application for the model.

6.1 Introduction: Model description

In this chapter, we analyze a space-time arrival process of customers served by a countable set of servers. This model is closely related to other allocation problems studied by Tassiulas and Ephremides [151] and Bambos et al. [159], [10], [24],[25], [26]. We consider a system where some jobs arrive exogenously and they are located in the space \mathbb{R}^d . A set of server stations serve the incoming jobs and each server station processes jobs at a rate depending on the location of the job, and a random environment variable.

This model is motivated by large scale wireless communication networks but it could suit other types of infinite queuing systems. In a wireless network scenario the customers are mobile users who want to receive some data from a network consisting of a set of base antennas. The position of a mobile user with respect to a base station determines the processing rate at which the base station serves the mobile user. A user may receive data simultaneously from several base stations, and an important issue is to find a resource sharing policy which maximizes the throughput of the network. Applications of this work to wireless networks are given in Chapter 7, Section 7.4. Other applications of resource allocation problems include flexible manufacturing systems and computing systems with competing tasks in a random environment.

In this chapter, we establish some results on the stability of this queuing system. An important aspect of this model is that the workload is not a vector in \mathbb{R}_+^d but an atomic measure with a total mass that is possibly infinite. This modelling contribution is the proper way to handle large spatial queuing systems and this setting could be used successfully in other spatial models. Another feature is that the number of server stations in the system may be infinite. All our results are proved in the stationary ergodic framework and independency is never required. The proofs of stability are based on generalizations of Loynes' sequences to general metric spaces. Some ideas of optimization theory are also used in the analysis of the stability region, and they pave the way to other developments.

The remainder of this section describes the model under consideration. Section 6.2 is dedicated to the stability analysis of our model. In Section 6.3, we examine a subclass of policies which preserves a kind of monotonicity for the workload measure. In Section 6.4 we determine the stability region when the spatial intensity measure is absolutely continuous with respect to the Lebesgue measure.

6.1.1 Customers arrival point process

All the random variables are defined on a common probability space (Ω, \mathcal{F}, P) . This space is endowed with a measurable flow $\{\theta_t\}, t \in \mathbb{R}$. We suppose that (P, θ_t) is *ergodic*.

The customers (or jobs) are points of a marked point process A . Namely A is a spatial marked point process on $\mathbb{R} \times \mathbb{R}^d$ with marks on \mathbb{R}_+ . The point process is represented as a counting measure $A = \sum_n \delta_{\{T_n, X_n, \sigma_n\}}$, where δ is the Dirac mass measure. The n^{th} job arrives at time $T_n \in \mathbb{R}$ located at $X_n \in \mathbb{R}^d$ and it requires a service time of $\sigma_n \in \mathbb{R}_+$. We assume that A is compatible with the flow θ : if $A(\omega) = \sum_n \delta_{\{T_n, X_n, \sigma_n\}}$ then $A \circ \theta_t(\omega) = \sum_n \delta_{\{T_n - t, X_n, \sigma_n\}}$. We assume also that for all bounded Borel sets $B \subset \mathbb{R}^{d+1}$, $EA(B) = E \sum_n \mathbf{1}(\{T_n, X_n\} \in B) < \infty$. Thus the intensity of A is a *Radon measure* and can be expressed as $\lambda(dx)dt$ (see for example Lemma A2.7.11., p.634 in Daley and Vere-Jones [55]). λ is not necessarily a finite measure on \mathbb{R}^d , and between time t and $t' > t$ an infinite number of jobs may arrive.

We define $P_A^{t,x}(\cdot)$ as the Palm probability of the point process A at $(t, x) \in \mathbb{R}^{d+1}$ (refer to [55], chapter 12). Since A is compatible with θ_t , we have: $P_A^{t,x}(\cdot) = P_A^{0,x}(\theta_{-t}\cdot)$. $\sigma_{t,x}$ will denote the required service time of a customer arriving at time t in x under $P_A^{t,x}$. We assume that $0 < E^{0,x}(\sigma_{0,x}) < +\infty$, $\lambda(dx)$ -a.e.. Remind that $E^{0,x}(\sigma_{0,x})$ can be interpreted as the mean service time requirement of a typical customer arriving at x .

6.1.2 Server stations policy

There is a *countable* set of server stations indexed by \mathcal{J} . The server j serves a customer located at x at rate $r_j(x)$. We assume that $x \mapsto r_j(x)$ is a positive measurable function and

$$\lim_{|x| \rightarrow +\infty} r_j(x) = 0, \quad (6.1)$$

where $|\cdot|$ denotes the Euclidean norm. The server stations are in a random environment and their processing powers vary over time. At time t , the total processing power available is $\epsilon_j(t) \in \mathbb{R}_+$. This process is compatible with the shift: $\epsilon_j(t) = \epsilon_j \circ \theta_t$, and $p_j = E\epsilon_j < +\infty$.

W_t is the workload at time t , it is the set of all jobs waiting to be processed. W_t is an atomic measure on \mathbb{R}^d , and $\int_B W_t(dx)$ is the sum of the remaining service times over all customers in B .

The server stations divide their processing power among active customers according to a policy scheme. This power allocation depends on the current workload. The system cannot process an infinite amount of service in finite time in a bounded set, more precisely:

$$\text{for all bounded borel set } B, \quad \sum_j p_j \sup_{x \in B} r_j(x) < +\infty. \quad (6.2)$$

Definition 6.1.1 *Let \mathcal{M} be the set of Radon measures on \mathbb{R}^d , endowed with the vague topology (refer to [55]). A policy $\pi = (\pi_j)_{j \in \mathcal{J}}$ is a measurable mapping from $\mathcal{M} \times \Omega$ to $\mathcal{M}^{\mathcal{J}}$ satisfying, for all $\omega \in \Omega$:*

$$\int_{\mathbb{R}^d} \pi_j(m, \omega)(dx) \leq \epsilon_j(\omega) \quad (6.3)$$

$$\pi_j(m, \omega) \text{ is absolutely continuous with respect to } m. \quad (6.4)$$

The policy enforced at time t is $\pi(W_t, \theta_t \omega)$.

The server stations cannot allocate more than their total processing power (Equation (6.3)). If the total workload in a set is zero, no processing power is allocated to this set (Equation (6.4)). The server station j achieves at time t an instantaneous service rate for a job located at x of: $r_j(x)\pi_j(W_t)(\{x\})$.

The policies under consideration are stationary: if W is stationary then $\pi(W_t, \theta_t \omega)$ is also stationary. The study of non-stationary policies is performed in [151] in a similar framework, in this article the authors show that the non-stationary and stationary policies have the same performances (as far as stability is concerned).

Here is a simple example of a deterministic policy defined for atomic measures:

$$\pi_j^+(m) = \begin{cases} 0 & \text{if } m \text{ is the measure zero} \\ \epsilon_j \delta_{x_j^+} & \text{otherwise.} \end{cases}$$

where, $x_j^+ = \arg \max \{x : r_j(x)\mathbf{1}(m(\{x\}) > 0)\}$. If multiple choices of x are possible, choose the first in the lexicographic order. With this policy, the server stations serve the user with the best processing rate first. In particular this policy is *work conserving*: if W_t is not the null measure, the server is active.

6.1.3 Evolution Equation

The time evolution of the workload measure is given by the equation: for all Borel sets B and $t' > t$,

$$W_{t'}(B) = W_t(B) + \int_t^{t'} \int_B \sigma_{s,x} A(ds \times dx) - \sum_j \int_t^{t'} \int_B r_j(x) \pi_j(W_s)(dx) ds. \quad (6.5)$$

Using Borovkov's terminology (see [42], chap. 4), Equation (6.5) defines a *stochastic recursive process*: we can write $W_{t+h} = f_h(W_t, A_t^{t+h})$, where A_t^{t+h} denotes the trajectory of the arrival point process A between t and $t+h$.

Under a given policy π , for a Radon measure m , we define W_t^m as the workload at time t if $W_0 = m$.

6.1.4 Some Examples

Example 6.1.2 All jobs arrive on a countable set of points: $\{x_i\}, i \in \mathbb{N}$, with no accumulation points. These points are waiting rooms and $\lambda_i = EA([0, 1] \times \{x_i\}) < +\infty$. In this example, the system reduces to a multi-class job traffic with processing rates depending both on the class and the server station. The stability region of this type of system has been examined in [159].

Example 6.1.3 In a wireless communication scenario, $d = 2$, the server stations are base antennas, and the customers are mobile users who receive some data from the network. The server station j is located at $Y_j \in \mathbb{R}^2$ and its processing rate function is $r_j(x) = L(x, Y_j)/I(x)$, where $L(x, y)$ is the attenuation function on the channel between x and y and $I(x) = \sum_{j \in \mathcal{J}} L(x, Y_j)$ is a shot noise process. A common assumption on the attenuation function is $L(x, y) \sim |y - x|^{-\alpha}$, with $\alpha > 2$. Motivations for this model are given in Chapter 7.

Example 6.1.4 When $\epsilon_j \in \{0, 1\}$, the model has a random connectivity. The server stations are switched on or switched off. At time t , if $\epsilon_j(t) = 1$ (resp. 0) the base station j is switched on (resp. switched off) (see also [26]).

6.2 Stability Analysis

6.2.1 Stability Region

A policy π is *stable* if there exists a point process M such that $\{M \circ \theta_t\}, t \in \mathbb{R}$, is a solution of Equation (6.5). The queuing system is said to be stable if there exists a stable policy. This definition is called *stochastic stability* in [24]. In §6.2.4, we examine a stronger definition of stability.

The parameter of the queuing system is the arrival marked point process A . Let \mathcal{N} be the set of arrival processes of finite intensity and finite mean service time, we define:

$$\mathcal{F} = \left\{ f = (x \mapsto f_j(x), j \in \mathcal{J}) \text{ such that,} \right. \\ \left. \forall j, f_j \text{ is non-negative, measurable and } \lambda(dx)\text{-a.e. } \sum_j f_j(x) = 1 \right\},$$

$$\mathcal{N}^s = \left\{ A \in \mathcal{N} : \exists f \in \mathcal{F} \text{ such that: } \forall j, \int_{\mathbb{R}^d} \frac{E_A^{0,x}(\sigma_{0,x}) f_j(x)}{r_j(x)} \lambda(dx) < p_j \right\}, \quad (6.6)$$

$$\bar{\mathcal{N}}^s = \left\{ A \in \mathcal{N} : \exists f \in \mathcal{F} \text{ such that: } \forall j, \int_{\mathbb{R}^d} \frac{E_A^{0,x}(\sigma_{0,x}) f_j(x)}{r_j(x)} \lambda(dx) \leq p_j \right\}. \quad (6.7)$$

These sets are generalized continuous versions of the stability sets introduced in [159]. Note that $\int_{\mathbb{R}^d} \frac{E_A^{0,x}(\sigma_{0,x})f_j(x)}{r_j(x)}\lambda(dx)$ is a traffic load: $E_A^{0,x}(\sigma_{0,x})\lambda(dx)$ is the mean service time per surface unit and $r_j(x)$ is the processing rate at x for server station j . We can now state our main result:

Theorem 6.2.1 *For the queuing model described above,*

- *if $A \in \mathcal{N}^s$, then there exists a stable policy,*
- *if there is a stable policy then $A \in \bar{\mathcal{N}}^s$.*

The stability region depends on the distribution of A only through its means. To fix ideas, if there is only one server station then all jobs arrive at the same location, say 0. The stability region is thus given by $E_A^{0,0}(\sigma_{0,0})\lambda(0) < p_1 r_1(0)$: this is the usual condition $\rho < 1$ for G/G/1 queues.

In the proof of the theorem, we establish that to a given stable policy π corresponds $(f_j)_{j \in \mathcal{J}}$ in \mathcal{F} such that:

$$\int_{\mathbb{R}^d} \frac{E_A^{0,x}(\sigma_{0,x})f_j(x)}{r_j(x)}\lambda(dx) \leq p_j.$$

f_j is the proportion of service carried by the server j for users in x in the stationary regime. The converse mapping is also available, for a set of functions $(f_j)_{j \in \mathcal{J}}$ in \mathcal{F} such that the above inequality is satisfied with a strict inequality, there exists a stable policy. In fact this last assertion will only be proved for a dense subset of functions of \mathcal{F} . The weakness of this theorem is the lack of precision on the policy which achieves the maximum permissible loading. The policy we build in the proof of the theorem is not practical.

6.2.2 Necessity for stability of Theorem 6.2.1

This technical lemma is needed in what follows (for a proof, see Lemma 2.2.1 [20]).

Lemma 6.2.2 *Let Z be a non-negative a.s. finite random variable, such that for a given t , $Z - Z \circ \theta_t \in L^1(P)$, then $E(Z - Z \circ \theta_t) = 0$.*

We assume that there exists a stable policy π and a stationary workload measure $W_t = W \circ \theta_t$. Let B be a bounded Borel set, from Equation (6.5),

$$W \circ \theta_t(B) = W(B) + \int_0^t \int_B \sigma_{s,x} A(ds \times dx) - \sum_j \int_t^{t+h} \int_B r_j(x) \pi_j(W \circ \theta_s)(dx) ds.$$

Let $\bar{\pi}_j(B) = E(\pi_j(W)(B))$, $\bar{\pi}_j$ is a Radon measure, and Equation (6.3) gives $\int_{\mathbb{R}^d} \bar{\pi}_j(dx) \leq p_j$. Using Assumption (6.2), we obtain

$$E(|W \circ \theta_t(B) - W(B)|) \leq t \int_B E_A^{0,x}(\sigma_{0,x})\lambda(dx) + t \sum_j p_j \sup_{x \in B} r_j(x) < +\infty.$$

Thus $W \circ \theta_t(B) - W(B) \in L^1(P)$, applying Lemma 6.2.2:

$$\int_B E_A^{0,x}(\sigma_{0,x})\lambda(dx) = \sum_j \int_B r_j(x) \bar{\pi}_j(dx). \quad (6.8)$$

Since Equation (6.8) holds for all bounded Borel sets, the measures: $\sum_j r_j(x) \bar{\pi}_j(dx)$ and $E_A^{0,x}(\sigma_{0,x})\lambda(dx)$ are equal. In particular the measure $r_j(x) \bar{\pi}_j(dx)$ is absolutely continuous with

respect to $E_A^{0,x}(\sigma_{0,x})\lambda(dx)$. Let $\tilde{\pi}_j(x)$ be the Radon-Nicodym derivative of $\bar{\pi}_j(dx)$ with respect to $\lambda(dx)$ and $f_j(x) = \frac{r_j(x)\tilde{\pi}_j(x)}{E_A^{0,x}(\sigma_{0,x})}$. We deduce from (6.8) that for all Borel B :

$$\int_B E_A^{0,x}(\sigma_{0,x})\lambda(dx) = \sum_j \int_B f_j(x)E_A^{0,x}(\sigma_{0,x})\lambda(dx).$$

Thus $\lambda(dx)$ -a.e. $\sum_j f_j(x) = 1$ and $f \in \mathcal{F}$. Finally, $\int_{\mathbb{R}^d} \bar{\pi}_j(dx) \leq p_j$ reads $\int_{\mathbb{R}^d} \frac{E_A^{0,x}(\sigma_{0,x})f_j(x)}{r_j(x)}\lambda(dx) \leq p_j$ and the second assertion of Theorem 6.2.1 follows.

6.2.3 Sufficiency for stability of Theorem 6.2.1

We first find some properties on the set \mathcal{N}^s as it is defined in Section 6.2.1. For $x \in \mathbb{R}^d$, let $\mathcal{J}_x = \{j : f_j(x) > 0\}$ and for a set B , $\mathcal{J}_B = \cup_{x \in B} \mathcal{J}_x$.

Proposition 6.2.3 *If \mathcal{N}^s is not empty, there is a $f \in \mathcal{F}$ such that for all j , $x \mapsto f_j(x)$ is continuous and for all bounded set B , $|\mathcal{J}_B|$ is finite.*

Proof. To simplify notations, $\nu_j(dx)$ will denote the measure $\frac{E_A^{0,x}(\sigma_{0,x})}{r_j(x)}\lambda(dx)$ and \mathcal{J} is set to be \mathbb{N} . Let $f \in \mathcal{F}$ such that $\forall j$, $\rho_j = \int_{\mathbb{R}^d} f_j(x)\nu_j(dx) < 1$. Let G be a open bounded set. For all j , from Lusin's Theorem (see for example [141]) there exists a sequence of continuous functions on G , $g_j^n(\cdot)$, such that $\nu_j(dx)$ -a.e., $0 \leq g_j^n(x) \leq f_j(x)$ and $\lim_n \int_G g_j^n(x)\nu_j(dx) = \int_G f_j(x)\nu_j(dx)$.

We have $\sum_j g_j^n(x) \leq 1 = \sum_j f_j(x)$. Let $\epsilon^n(x) = 1 - \sum_{j \neq 1} g_j^n(x)$. We define

$$f_j^n(x) = \begin{cases} g_j^n(x) + \mathbf{1}_{j=1}\epsilon^n(x) & \text{if } x \in G \\ f_j(x) & \text{if } x \notin G. \end{cases}$$

We check that f^n is in \mathcal{F} and for n large enough: $\forall j$, $\int_{\mathbb{R}^d} f_j^n(x)\nu_j(dx) < 1$. By iterating this construction for a set of open sets covering the \mathbb{R}^d , we deduce that there exists an $f \in \mathcal{F}$, such that $\forall j$, $\rho_j = \int_{\mathbb{R}^d} f_j(x)\nu_j(dx) < 1$ and f_j continuous.

Now we turn to the second part of the proposition. Let K be a compact subset, f_j as above and $\max(\rho_j, \frac{1}{2}) < \rho'_j < 1$. We define $g_j(x) = \frac{f_j(x)}{\rho'_j}$, $\int_{\mathbb{R}^d} g_j(x)\nu_j(dx) = \frac{\rho_j}{\rho'_j} < 1$ and $\sum_j g_j(x) > 1$. For all x , there exists j_x such that $\sum_{j=1}^{j_x} g_j(x) > 1$. By continuity, since K is compact, $j_K = \sup_{x \in K} j_x$ is finite. It is immediate to check that $\tilde{f}_j(x) = \frac{g_j(x)\mathbf{1}_{j \leq j_x}}{\sum_{j \leq j_x} g_j(x)}$ has all the required properties. \square

We can then turn back to the proof of Theorem 6.2.1. We suppose $A \in \mathcal{N}^s$: there exists $(f_j), j \in \mathcal{J}$, in \mathcal{F} such that for all j , $\int_{\mathbb{R}^d} \frac{E_A^{0,x}(\sigma_{0,x})f_j(x)}{r_j(x)}\lambda(dx) < 1$. We can assume that f has the properties given in Proposition 6.2.3. For a given policy π and an initial atomic workload m , we define the set:

$$\mathcal{A}_j^m(t) = \left\{ x : r_j(x) \int_0^t \pi_j(W_s^m)(\{x\})ds \leq f_j(x)(m(\{x\}) + \int_{[0,t] \times \{x\}} \sigma_{s,x} A(ds \times dx)) \right\},$$

$x \in \mathcal{A}_j^m(t)$ means that the contribution of server j is a proportion of at most $f_j(x)$ of the jobs arrived at x . Consider the following non-stationary policy: for all $j \in \mathcal{J}$ and $t \geq 0$:

$$\pi_j(t) = \begin{cases} \epsilon_j(t)\delta_{x_j^*} & \text{if } \mathcal{A}_j^{W_0}(t) \neq \emptyset \\ 0 & \text{if } \mathcal{A}_j^{W_0}(t) = \emptyset. \end{cases} \quad (6.9)$$

where, $x_j^* = \arg \max \{x : \mathbf{1}(x \in \mathcal{A}_j^{W_0}(t))\mathbf{1}(W_t(\{x\}) > 0)\}r_j(x)$ if multiple choices of x_j^* are possible, choose the first in the lexicographic order. The existence of this policy follows from

Assumption (6.1). The policy π divides the workload among all servers with proportions f_j and processes the jobs at the faster available rate. $\pi_j(t)$ is the policy enforced at time t , and with the usual notations, $\pi_j(t) = \pi_j(W_t^m)$.

Note also that if $\mathcal{A}_j^m(T) = \emptyset$ for some T , then the server j will only serve after time T jobs arrived after time T and for $t > 0$:

$$\mathcal{A}_j^m(t+T) = \mathcal{A}_j^0(t) \circ \theta_T. \quad (6.10)$$

Let B be a bounded Borel set, we have:

$$\begin{aligned} W_t(B) &= \int_0^t \int_B \sigma_{s,x} A(ds \times dx) - \sum_j \int_0^t \int_B r_j(x) \pi_j(s)(dx) ds \\ &= \sum_j \int_0^t \int_B f_j(x) \sigma_{s,x} A(ds \times dx) - \sum_j \int_0^t \int_B r_j(x) \pi_j(s)(dx) ds \\ &= \sum_j \int_B r_j(x) \tilde{W}_t^j(dx), \end{aligned}$$

where:

$$\tilde{W}_t^j = \int_0^t \int_B \frac{f_j(x) \sigma_{s,x}}{r_j(x)} A(ds \times dx) - \int_0^t \int_B \pi_j(s)(dx) ds. \quad (6.11)$$

We now define a total order \prec_j on \mathbb{R}^d : $x \succ_j y$ if $r_j(x) > r_j(y)$ or $r_j(x) = r_j(y)$ and x is in the lexicographic order smaller than y . A Borel set B is a j -max set if $B = \cup_{y \in B} \{x : x \succeq_j y\}$.

Lemma 6.2.4 For a j -max set B :

$$\begin{aligned} \tilde{W}_t^j(B) &= \left(\max \left(\int_B \frac{f_j(x) W_0(dx)}{r_j(x)} + \int_0^t \int_B \frac{f_j(x) \sigma_{s,x}}{r_j(x)} A(ds \times dx) - \int_0^t \epsilon_j(s) ds, \right. \right. \\ &\quad \left. \left. \sup_{0 \leq h \leq t} \int_0^h \int_B \frac{f_j(x) \sigma_{s,x}}{r_j(x)} A(ds \times dx) - \int_0^h \epsilon_j(s) ds \right) \right)^+. \end{aligned}$$

Proof. The policy π divides the system with the set of servers \mathcal{J} into different queues, one for each server in \mathcal{J} with an incoming workload equal to:

$$\sum_j \int_0^t \int_B f_j(x) \sigma_{s,x} A(ds \times dx).$$

$\tilde{W}_t^j(B)$ is the rescaled workload: the server j serves the user at x with a unit processing rate. If B is a j -max set, from the definition of policy π_j , the server j allocates all its processing power to B if the workload in B is not 0. The customers in $\mathbb{R}^d \setminus B$ are served if there is no customer in B . Thus the statement of the lemma follows from the usual formula for the G/G/1 queue. \square

Let $M_t = W_t^0 \circ \theta_{-t}$ be the Loynes' sequence under policy π and $\tilde{M}_t^j = \tilde{W}_t^0 \circ \theta_{-t}$. We have:

$$M_t(B) = \sum_j \int_B r_j(x) \tilde{M}_t^j(dx).$$

Lemma 6.2.4 implies that $\tilde{M}_t^j(B)$ is a non-decreasing sequence for a j -max set. We say that two processes $\{X_t\}_{t \in \mathbb{R}_+}$ and $\{Y_t\}_{t \in \mathbb{R}_+}$ couple if there exists T such that for $t \geq T$: $X_t = Y_t$.

Lemma 6.2.5 As t tends to infinity, \tilde{M}_t^j couples a.s. with \tilde{M}_∞^j , a finite random measure.

Proof. Let B be a j -max set, from the Birkhoff's Theorem a.s.:

$$\lim_{t \rightarrow +\infty} \frac{1}{t} \int_{-t}^0 \int_B \frac{f_j(x) \sigma_{s,x}}{r_j(x)} A(ds \times dx) = \int_B \frac{f_j(x) E_A^{0,x}(\sigma_{0,x})}{r_j(x)} \lambda(dx) < 1.$$

Therefore $\tilde{M}_t^j(B) = (\sup_{0 \leq h \leq t} \int_{-h}^0 \int_B \frac{f_j(x) \sigma_{s,x}}{r_j(x)} A(ds \times dx) - h)^+$ is a bounded increasing sequence and it couples with $\tilde{M}_\infty^j(B) = (\sup_{h \in \mathbb{R}_+} \int_{-h}^0 \int_B \frac{f_j(x) \sigma_{s,x}}{r_j(x)} A(ds \times dx) - h)^+$.

\mathbb{R}^d is a j -max set and for any set B : $\tilde{M}_t^j(B) \leq \tilde{M}_t^j(\mathbb{R}^d) \leq \tilde{M}_\infty^j(\mathbb{R}^d)$. Thus a subsequence $\tilde{M}_{t_n}^j(B)$ converges to $\tilde{M}_\infty^j(B)$ and \tilde{M}_∞^j is well defined as a finite random measure.

Since $\tilde{W}_t^j(\mathbb{R}^d)$ is a G/G/1 queue, we can define T the first time after the coupling time with $\tilde{M}_\infty^j \circ \theta_t(\mathbb{R}^d)$ such that $\tilde{W}_t^j(\mathbb{R}^d) = 0$, T is a.s. finite. In view of Equation (6.10), for $t \geq T$, $\tilde{W}_t^j = \tilde{M}_\infty^j \circ \theta_t$. Thus: $\tilde{M}_t^j = \tilde{W}_t^j \circ \theta_{-t} = \tilde{M}_\infty^j$ and \tilde{M}_t^j couples with \tilde{M}_∞^j . \square

Let B be a bounded set. For the choice of f given by Proposition 6.2.3:

$$M_t(B) = \sum_{j \in \mathcal{J}_B} \int_B r_j(x) \tilde{M}_t^j(dx), \quad (6.12)$$

with \mathcal{J}_B finite. We deduce from Lemma 6.2.5 that $M_t(B)$ couples a.s. with $M_\infty(B) = \sum_{j \in \mathcal{J}_B} \int_B r_j(x) \tilde{M}_\infty^j(dx)$. We thus have proved the existence of the limit: $\lim_{t \rightarrow \infty} M_t = M_\infty$. To conclude the proof, it remains to prove that M_∞ is a stationary solution of Equation (6.5) for a policy π' .

Along the line of Lemma 6.2.5, we can also prove that the process $\{\tilde{M}_{t+s}^j \circ \theta_s\}_{0 \leq s \leq h}$ couples with $\{\tilde{M}_\infty^j \circ \theta_s\}_{0 \leq s \leq h}$ for any positive h . From Equation (6.11):

$$\begin{aligned} \tilde{M}_{t+h}^j \circ \theta_h(B) &= \int_{-t-h}^0 \int_B \frac{f_j(x) \sigma_{s,x}}{r_j(x)} A(ds \times dx) - \int_0^{t+h} \int_B \pi_j(\theta_{-t}, s)(dx) ds \\ &= \tilde{M}_t^j(B) + \int_0^h \int_B \frac{f_j(x) \sigma_{s,x}}{r_j(x)} A(ds \times dx) - \int_0^h \int_B \pi_j(\theta_{-t}, t+s)(dx) ds. \end{aligned}$$

If Z denotes the coupling time of $\{\tilde{M}_{t+s}^j \circ \theta_s(B)\}_{0 \leq s \leq h, j \in \mathcal{J}_B}$, for $t \geq Z$ we have:

$$\int_0^h \int_B \pi_j(\theta_{-t}, t+s)(dx) ds = \tilde{M}_\infty^j \circ \theta_h(B) - \tilde{M}_\infty^j(B) + \int_0^h \int_B \frac{f_j(x) \sigma_{s,x}}{r_j(x)} A(ds \times dx).$$

For all h , the right hand side of the last equation does not depend on t , thus $\pi_j(\theta_{-t}, t+s)$ couples a.e. with a measure $\pi'_j(s) = \lim_t \pi_j(\theta_{-t}, t+s)$. Let T' such that the coupling occurs, we have $\pi'_j(s) = \lim_t \pi_j(\theta_{-t+s-T'}, \theta_s, t+T'-s+s) = \pi'_j(T') \circ \theta_{s-T'}$. As a consequence, π' is a stationary policy and M_∞ is a stationary solution of Equation (6.5). Theorem 6.2.1 is proved.

Remark 6.2.6 *In the particular case described in example 6.1.2, a simpler proof is available.*

We have : $\sum_i \frac{\lambda_i E_A^{0,x_i}(\sigma_{0,x_i}) f_j(x_i)}{r_j(x_i)} = \rho_j < 1$. Consider the following deterministic policy defined for atomic measure with atoms on $\{x_i\}, i \in \mathbb{N}$:

$$\pi_j(m)(\{x_i\}) = \epsilon_j \mathbf{1}(m(\{x_i\}) \neq 0) \frac{f_j(x_i) \lambda_i E_A^{0,x_i}(\sigma_{0,x_i})}{r_j(x_i) \rho_j}.$$

Computing $M_t(\{x_i\})$, it appears that this policy is stable.

6.2.4 Convergence toward a Stationary Solution

If there exists a stationary regime in a queuing system it is important to know if for any initial condition the workload converges in some sense to the stationary regime. The following proposition gives a positive answer for the policy defined in the proof of Theorem 6.2.1.

Proposition 6.2.7 *If the policy scheme defined by Equation (6.9) is enforced, for any finite initial workload at time $t = 0$, for all bounded Borel set B , $\{W_{t+T}(B)\}, t \in \mathbb{R}_+$, converges in variation toward $\{M \circ \theta_t(B)\}, t \in \mathbb{R}_+$, as T tends to infinity.*

Note that the workload measure does not converge in variation, convergence happens only on bounded sets. The proposition states that the workload converges in variation for the vague topology.

Proof. The proof relies on the following fact: if a stochastic process $\{X_t\}$ couples with $\{Y \circ \theta_t\}$ then $\{X_{t+T}\}, t \in \mathbb{R}_+$, converges in variation toward $\{Y \circ \theta_t\}, t \in \mathbb{R}_+$, as T tends to infinity (see Lindvall [115] or Theorem 2.4.1. of [20]).

From Lemma 6.2.4, $\tilde{W}_t^j(\mathbb{R}^d)$ is G/G/1 queue, therefore the coupling of $\tilde{W}_t^j(\mathbb{R}^d)$ for any initial condition follows from Property 2.4.1. in [20]. For a general Borel set B , it suffices to notice $\tilde{W}_t^j(B) \leq \tilde{W}_t^j(\mathbb{R}^d)$. The same arguments used in the proof of Theorem 6.2.1 works to show that $\tilde{W}_t^j(B)$ couples for any initial condition. If B is a bounded set, $W_t(B) = \sum_{j \in \mathcal{J}_B} \int_B r_j(x) \tilde{M}_t^j(dx)$. Since \mathcal{J}_B is finite, the coupling also occurs. \square

6.3 Monotone cone policies

6.3.1 Loynes' sequence for Monotone policies

The policy we have defined to prove the sufficiency part of Theorem 6.2.1 is not interesting. In particular, it requires the knowledge of the functions f_j . Along the line of the work done in [151], [10], [24], it would be very appealing to find some stable policy which does not rely on the knowledge of the parameters of the system. In this section, we first give some material on Loynes' sequence on Polish space and then we establish some sufficient conditions on the stability.

The framework of Loynes' Theorem for general Polish space is given in §2.5.2. of [20], (see also §C.1, in this Appendix). The space \mathcal{M} is a Polish space for the vague topology (refer to [55]). We define a partial order \preceq on \mathcal{M} , the set of Radon measures on \mathbb{R}^d . Let m and m' be two Radon measures, $m' \preceq m$ if for all bounded Borel set B in \mathbb{R}^d , $m'(B) \leq m(B)$. A policy is said to be *monotone* if $m' \preceq m$ implies for all $t \in \mathbb{R}_+$, $W_t^{m'} \preceq W_t^m$.

In the sequel 0 will denote the null measure on \mathbb{R}^d . The *Loynes' sequence* $(M_t, t \in \mathbb{R}_+)$ is defined as the workload at time 0 when the workload was the null measure at time $-t$, that is:

$$M_t = W_t^0 \circ \theta_{-t}.$$

These two classical lemmas are straightforward.

Lemma 6.3.1 *Let $(m_n, n \in \mathbb{N})$ be a monotone sequence in \mathcal{M} for \preceq , such that for all bounded Borel sets B , $m_n(B)$ is bounded. Then, $(m_n, n \in \mathbb{N})$ converges in \mathcal{M} for the vague topology.*

Lemma 6.3.2 *Suppose π is a monotone policy then $\{M_t\}, t \in \mathbb{R}_+$, is non-decreasing sequence (for \preceq).*

In view of Lemma 6.3.2, the Loynes' sequence is of particular interest for the class of monotone policies. Indeed, if $(M_t), t \in \mathbb{R}_+$, is an non-decreasing sequence and is bounded by a random

Radon measure Z (for \preceq), using Lemma 6.3.1, M_t converges a.s. in \mathcal{M} and we can then define the *Loynes' variable* as:

$$M_\infty = \lim_{t \rightarrow +\infty} M_t.$$

Monotone policies are quite natural in our setting. Most known processing policies are monotone. Here comes an important example.

Example 6.3.3 This class of policies has emerged in papers, see [151], [10], [24]. Let $\alpha > 0$, we define for an atomic policy m , $A_j(m) = \arg \max \{x : m(\{x\})^\alpha r_j(x)\}$ and:

$$\pi_j(m) = \begin{cases} C(m)\epsilon_j \sum_{x \in A_j(m)} r_j(x)^{-\frac{\alpha+1}{\alpha}} \delta_x & \text{if } m \neq 0 \\ 0 & \text{if } m = 0. \end{cases}$$

where $C(m)$ is the constant such that $\int_{\mathbb{R}^d} \pi_j(m)(dx) = \epsilon_j$ if $m \neq 0$. Notice that $\pi(cm) = \pi(m)$ for $c > 0$. For finite workload measures, it can be shown that this policy is monotone. However, it is not clear whether or not this policy is stable when $A \in \mathcal{N}^s$.

Definition 6.3.4 Let g be a measurable mapping from \mathcal{M} to \mathcal{M} . We say that g is *left continuous* (resp. *right continuous*) if for all non-decreasing (resp. non-increasing) converging sequence $(m_n), n \in \mathbb{N}$, of \mathcal{M} , $\lim_n g(m_n) = g(\lim_n m_n)$.

It is consistent to define some continuity properties with converging sequences since \mathcal{M} is a complete metric space. Right continuous policies are not of practical interest, indeed a work conserving policy cannot be right continuous. The cone policies of example 6.3.3 are left continuous. We define the *discontinuity set* of a function h as $\text{disc}(h) = \{x : h(x) \text{ not continuous at } x\}$.

Proposition 6.3.5 Suppose π_j is left continuous and $\lambda(\text{disc}(r_j)) = 0$ for all $j \in \mathcal{J}$. When M_∞ is Radon, it is a stationary solution of Equation (6.5).

Proof. By definition, $W_s^{M_t} = W_{t+s}^0 \circ \theta_{-t} = W_{t+s}^0 \circ \theta_{-s-t} \circ \theta_s = M_{t+s} \circ \theta_s$, hence, using Equation (6.5), for a Borel set B and $t \in \mathbb{R}_+$:

$$\begin{aligned} M_{t+h} \circ \theta_h(B) &= W_h^{M_t}(B) \\ &= M_t(B) + \int_0^h \int_B \sigma_{s,x} A(ds, dx) \\ &\quad - \sum_j \int_0^h \int_B r_j(x) \pi_j(M_{t+s} \circ \theta_s)(dx) ds. \end{aligned} \tag{6.13}$$

If $(t_k), k \in \mathbb{N}$, is an increasing sequence converging toward $+\infty$, $(M_{t_k+s} \circ \theta_s), k \in \mathbb{N}$, is a non-decreasing sequence converging toward $M_\infty \circ \theta_s$. Since π_j is left continuous, we have for the vague convergence: $\lim_{k \rightarrow +\infty} \pi_j(M_{t_k+s} \circ \theta_s) = \pi_j(M_\infty \circ \theta_s)$.

For $A = \sum_n \delta_{T_n, X_n, \sigma_n}$, we define $C = \{X_n, n \in \mathbb{N}\}$ and let B be a bounded Borel set such that $C \cap \partial B = \emptyset$. ∂B avoids a countable set of points in \mathbb{R}^d . From Equation (6.5) and Assumption (6.4), $M_\infty \circ \theta_s$ and $\pi_j(M_\infty) \circ \theta_s$ are atomic measures and they are supported by $\sum_k \delta_{X_k} \mathbf{1}(T_k < s)$. Thus, for B as above and s in \mathbb{R} , we obtain $\pi_j(M_\infty \circ \theta_s)(\partial B) = 0$. Note also that $\lambda(\text{disc}(r_j)) = 0$ implies that a.s. $\pi(M_\infty \circ \theta_s)(\text{disc}(r_j)) = 0$. From Lemma B.2 (in Appendix), we deduce a.s.:

$$\lim_{k \rightarrow +\infty} \int_B r_j(x) \pi_j(M_{t_k+s} \circ \theta_s)(dx) = \int_B r_j(x) \pi_j(M_\infty \circ \theta_s)(dx).$$

Now, from Assumption (6.2), $\sum_j \int_0^h \int_B r_j(x) \pi_j(M_{t+s} \circ \theta_s)(dx) \leq \sum_j h \sup_{x \in B} r_j(x) < +\infty$, by the dominated convergence theorem, a.s.:

$$M_\infty \circ \theta_h(B) = M_\infty(B) + \int_0^h \int_B \sigma_{s,x} A(ds, dx) - \sum_j \int_0^h \int_B r_j(x) \pi_j(M_\infty \circ \theta_s)(dx).$$

Then, using the forthcoming Lemma 6.3.6, this last equation is indeed satisfied for all Borel sets and M_∞ is a stationary solution. \square

Lemma 6.3.6 *Let \mathcal{C} be a countable set of points in \mathbb{R}^d and \mathcal{C} the set of bounded Borel sets of \mathbb{R}^d with $\mathcal{C} \cap \partial B = \emptyset$. Then:*

- \mathcal{C} is an algebra and the σ -algebra generated by \mathcal{C} , $\sigma(\mathcal{C})$ is the Borel σ -algebra \mathcal{B} .
- From a measure m defined on \mathcal{C} , there is a unique extension to m on \mathcal{B} .

Proof. From the relations: $\partial(A \cap B) \subset \partial A \cap \partial B$, $\partial(A \cup B) \subset \partial A \cup \partial B$ and $\partial(A^c) = \partial A$ it follows that \mathcal{C} is an algebra.

\mathcal{B} is the σ -algebra of the algebra generated by the open rectangles of \mathbb{R}^d . To prove the first assertion of our lemma, it suffices to prove that the rectangle $]0, 1[^d$ can be written as $\cup_{n \in \mathbb{N}} B_n$, where $B_1 \subset B_2 \dots \subset B_n \in \mathcal{C}$. To this end, consider the rectangle $R_\epsilon =]\epsilon, 1 - \epsilon[^d$, with $0 < \epsilon < \frac{1}{2}$. If $\epsilon \neq \epsilon'$, $\partial R_\epsilon \cap \partial R_{\epsilon'} = \emptyset$. Since \mathcal{C} is countable there can only be a countable set of ϵ such that $\mathcal{C} \cap \partial R_\epsilon \neq \emptyset$. In particular, there exists an increasing sequence ϵ_n such that $\mathcal{C} \cap \partial R_{\epsilon_n} = \emptyset$. We have proved the first statement of the lemma. The second assertion is the Caratheodory's Extension Theorem. \square

The assumptions of Proposition 6.3.5 can be changed as follows. Let $E = \{\omega \in \Omega : \exists T, \forall t > T, M_t(\omega) = M_\infty(\omega)\}$. On E , M_t converges in variation (or couples). We easily check that E is a θ_t -invariant event and by ergodicity $P(E) \in \{0, 1\}$. If $P(E) = 1$ then M_t couples with M_∞ a.s. and the assumptions on the continuity of π_j and r_j are no more needed to ensure the stationarity of M_∞ .

Corollary 6.3.7 *For a given policy π , if $M_t = W_t \circ \theta_{-t}$ couples with M_∞ then M_∞ is a stationary workload solution of Equation (6.5).*

6.3.2 Stability of cone policies and saturation rule

A *cone policy* is policy π such that for all $c > 0$, $\pi(cm) = \pi(m)$. The policy π^+ described in §6.1.2 and the policy described in Example 6.3.3 are examples of cone policies. In this paragraph, we show how to determine the stability region of some monotone cone policies. This technique uses the saturation rule developed by Baccelli and Foss [21] (we will refer to [20], §2.11.3-4). In this paragraph we will assume that:

$$(A6.3.2) \left\{ \begin{array}{l} (i) \quad \lambda \text{ has a compact support } K, \\ (ii) \quad x \mapsto r_j(x) \text{ is continuous,} \\ (iii) \quad \epsilon_j = 1 \text{ (the environment is deterministic).} \end{array} \right.$$

Assumptions (ii) and (iii) may be overcome. Assumption (i) is of more fundamental nature. It relies on the saturation rule as it is stated in [20], the arrival process intensity needs to have a finite total mass.

Let \widetilde{W}_t^m be the workload at time $t \geq 0$ when at time 0 the initial workload is m and when the arrival process is empty:

$$\widetilde{W}_t^m = m - \sum_j \int_0^t r_j \cdot \pi_j(\widetilde{W}_s^m) ds.$$

We define the Radon measure associated to the arrival load intensity: $\nu(dx) = E_A^{0,x}(\sigma_{0,x})\lambda(dx)$, the time needed to empty this load is

$$\tau = \inf\{t \geq 0 : \widetilde{W}_t^\nu = 0\}.$$

From Assumption (i), the arrival point process A can be rewritten as:

$$A = \sum_{k \in \mathbb{Z}} \delta_{\{T_k, X_k, \sigma_k\}},$$

where a.s. $T_k < T_{k+1}$ and $T_0 = \sup\{k : T_k \leq 0\}$. We define a partial ordering on the arrival counting measures. Let $A_1 = \sum_{k \leq 0} \delta_{\{T_k, X_k, \sigma_k\}}$ with support on $\mathbb{R}_- \times \mathbb{R}^d \times \mathbb{R}_+$ and $A_2 = \sum_{k \leq 0} \delta_{\{T'_k, X_k, \sigma'_k\}}$, $A_1 \preceq_t A_2$ if for all $k \leq 0$, $T'_k \leq T_k$ and $\sigma'_k \leq \sigma_k$. A policy is *externally monotone* if $A_1 \preceq_t A_2$ and for some $t \geq 0$, $W_t^0(A_2) = 0$ implies that $W_t^0(A_1) = 0$, where $W_t^0(A_i)$ is the workload at time $t \geq 0$ when the arrival counting measure is A_i . Note that a externally monotone policy is also a monotone policy.

The next result gives a simple criterion to determine the stability of externally monotone cone policies. Note however that proving that a policy is externally monotone may require some work.

Theorem 6.3.8 *Under the foregoing assumptions (A6.3.2), let π be a work conserving externally monotone cone policy. Assume that for all t , the mapping $m \mapsto W_t^m(\mathbb{R}^d)$ is continuous for the vague topology on \mathcal{M} . The policy is stable if $\tau < 1$ and unstable if $\tau > 1$.*

Proof. Let $t > 0$ and $c > 0$, we easily check that for any cone policy, the following nice scaling property holds:

$$\widetilde{W}_{ct}^m = t \widetilde{W}_c^{\frac{m}{t}}, \quad (6.14)$$

For $t > s$, the arrival process between times s and t is $A_s^t = \sum_k \mathbf{1}(s \leq T_k < t) \delta_{\{T_k, X_k, \sigma_k\}}$. Let $A(s, t) = \sum_k \mathbf{1}(s \leq T_k < t) \delta_{\{X_k, \sigma_k\}}$. For $s > 0$, we define the maximal dater of the system by

$$Z_s = \inf\{t > 0 : W_t^0(A_0^s \circ \theta_{-s}) = 0\},$$

that is the time needed to empty the system when the arrival process is restricted to the interval $[-s, 0)$. We introduce:

$$\widetilde{Z}_s = \inf\{t > 0 : \widetilde{W}_t^{A(-s,0)} = 0\}.$$

Note that the external monotonicity of the policy π implies that $Z_s \leq \widetilde{Z}_s$. From Equation (6.14)

$$\frac{\widetilde{Z}_s}{s} = \inf\{t > 0 : \widetilde{W}_t^{\frac{A(-s,0)}{s}}(\mathbb{R}^d) = 0\}.$$

The ergodicity of A implies that a.s. $\frac{A(-s,0)}{s}$ converges to ν for the vague topology. Thus by continuity, for all t , $\widetilde{W}_t^{\frac{A(-s,0)}{s}}(\mathbb{R}^d)$ converges as s tends to infinity a.s. to $\widetilde{W}_t^\nu(\mathbb{R}^d)$.

Fix $j_0 \in \mathcal{J}$, from Equation (6.2) and Assumption (ii), there exists $C > 1$ such that

$$\forall x \in K : r_j(x) \leq C \text{ and } r_{j_0}(x) \geq C^{-1}. \quad (6.15)$$

The policy is work conserving, therefore if $\widetilde{W}_t(\mathbb{R}^d) > 0$ and $h \leq C \widetilde{W}_t(\mathbb{R}^d)$,

$$C^{-1}h \leq \widetilde{W}_t(\mathbb{R}^d) - \widetilde{W}_{t+h}(\mathbb{R}^d) \leq Ch.$$

This last property implies the continuity of \tilde{Z}_s , so we finally obtain

$$\lim_{s \rightarrow +\infty} \frac{\tilde{Z}_s}{s} = \inf\{t > 0 : \widetilde{W}_t^\nu(\mathbb{R}^d) = 0\}.$$

For $t > s$, let $X(A_s^t) = \inf\{u > 0 : W_u^0(A_s^t) = 0\}$, be the time of last activity in the network when the arrival process is A_s^t . We can apply the saturation rule to X . Indeed all the assumptions (1)-(4) p.162 in [20] are satisfied. Causality is clear, homogeneity and separability come from Assumption (iii) and external monotonicity comes from the assumption that π is externally monotone.

Assume first that $\tau < 1$. By Theorem 2.11.3 in [20], a.s. $\lim_{t \rightarrow \infty} Z_t = Z$ is finite. Equation (6.15) implies an upper bound on the total mass of $M_t = W_t^0 \circ \theta_{-t} = W_t^0(A_0^t \circ \theta_{-t})$:

$$M_t(\mathbb{R}^d) \leq CZ_t \leq CZ.$$

We deduce that the Loynes' variable is well defined. The stability is then a consequence of Proposition 6.3.5.

Assume on the contrary that there exists a stationary solution of Equation (6.5), say $(Y_t)_{t \in \mathbb{R}}$. We need to show that $\tau \leq 1$. Let $t \geq 0$, since $0 \preceq Y_{-t}$, the monotonicity of π implies that $M_t \preceq Y_0$. Therefore by Proposition 6.3.5, the Loynes' variable is well defined. Equation (6.15) implies a lower bound on the total mass of M_t :

$$C^{-1}Z_t \leq M_t(\mathbb{R}^d) \leq Y_0(\mathbb{R}^d).$$

This last inequality implies that a.s. $\lim_{t \rightarrow \infty} Z_t < \infty$. By Theorem 2.11.3 in [20] we deduce that $\tau \leq 1$. \square

6.4 Spatial Allocation

In this section, we suppose that the spatial arrival intensity $\lambda(dx)$ is absolutely continuous with respect to the Lebesgue measure: it is expressed as $\lambda(x)dx$. From Theorem 6.2.1 the stability relies on:

$$\rho = \inf_{f \in \mathcal{F}} \sup_{j \in \mathcal{J}} \frac{1}{p_j} \int_{\mathbb{R}^d} \frac{E_A^{0,x}(\sigma_{0,x})f_j(x)}{r_j(x)} \lambda(x)dx. \quad (6.16)$$

If $\rho < 1$, the system is stable, if $\rho > 1$, the system is unstable. In this section, we analyze this optimization problem. The geometry of the network is hidden in the processing rates r_j . There is a mapping from an f in \mathcal{F} to a stable policy π , an optimal policy is thus given by a choice of f that maximizes the permissible traffic load.

6.4.1 Optimal Spatial Allocation

We define:

$$\rho_j(f) = \frac{1}{p_j} \int_{\mathbb{R}^d} \frac{E_A^{0,x}(\sigma_{0,x})f_j(x)}{r_j(x)} \lambda(x)dx \quad \text{and} \quad \rho(f) = \sup_j \rho_j(f).$$

\mathcal{F} is a convex closed set and $f \mapsto \rho(f)$ is a convex function, thus the minimum of Equation (6.16) is reached and we define

$$\mathcal{F}^* = \{f \in \mathcal{F} : \rho(f) = \rho\}.$$

The extremal points of the convex set \mathcal{F} are the measurable functions such that $f_j(x) = \mathbf{1}(x \in V_j)$, for a Borel set V_j . This class of function is called *tessellation*. A tessellation is

a partition of the space: there exists a set D of null measure such that each point in $\mathbb{R}^d \setminus D$ belongs to a unique V_j . The policy scheme which corresponds to a tessellation is a cellular policy: a customer is served only by one server station.

Proposition 6.4.1 *If ρ is finite there is an $f \in \mathcal{F}$ such that:*

$$\forall j, \quad \rho_j(f) = \rho.$$

If there is a finite number of server stations, all $f \in \mathcal{F}^$ satisfy the above equation.*

Proof. Let $f \in \mathcal{F}$ and suppose for example, $\rho_1(f) < \rho_2(f)$, since, $\rho_2(f) > 0$, f_2 is not a.e. equal to 0. Thus, there exists a measurable non negative function $x \mapsto \epsilon(x)$ such that $f_2^\epsilon(x) = f_2(x) - \epsilon(x) \geq 0$, $f_1^\epsilon(x) = f_1(x) + \epsilon(x) \leq 1$ and $\rho_2(\epsilon) > 0$. Let $f_j^\epsilon(x) = f_j(x)$, for $j \notin \{1, 2\}$. $f^\epsilon \in \mathcal{F}$ and we have $\rho_1(f^\epsilon) = \rho_1(f) + \rho_1(\epsilon)$ and $\rho_2(f^\epsilon) = \rho_2(f) - \rho_2(\epsilon)$. Thus for $\rho_1(\epsilon)$ small enough, $\sup_{j \in \{1, 2\}} \rho_j(f^\epsilon) < \sup_{j \in \{1, 2\}} \rho_j(f)$ and $\rho(f^\epsilon) \leq \rho(f)$.

Suppose now that $f \in \mathcal{F}^*$, then f^ϵ is also in \mathcal{F}^* . By iterating the construction above for all j, j' , such that $\rho_{j'}(f) < \rho_j(f)$, the proposition follows. \square

Proposition 6.4.1 as an intuitive meaning: for an optimal spatial allocation, the traffic load is the same on each server station. We can prove a more surprising result. We say that the processing rates are *singular* if there exist j, k in \mathcal{J} , a constant $C > 0$ and a Borel set A of positive Lebesgue measure such that:

$$\forall x \in A, \quad r_j(x) = Cr_k(x).$$

Proposition 6.4.2 *If ρ is finite and if the processing rates are not singular, then there is an $f \in \mathcal{F}^*$ which is a tessellation.*

If there is finite number of server stations, all $f \in \mathcal{F}^$ are tessellations.*

This proposition gives a counter-intuitive result: the server stations do not need to share the jobs to reach the stability region. All the difficulty is to find the optimal tessellation which reaches the optimum. This result is not very surprising from the point of view of convex optimization: it only asserts that the extremum is reached at an extremal point.

The definition of singular processing rates is purely technical and does not rely on any natural assumption on the processing rates. In the wireless scenario (example 6.1.3) if $Y_j \neq Y_k$ for all $j, k \in \mathcal{J}$ and l is a strictly convex function then the processing rates are non-singular.

Proof. We consider the $f \in \mathcal{F}^*$ given by proposition 6.4.1. Let $E = f_1([0, 1])^{-1} \cap f_2([0, 1])^{-1}$. In this proof, μ will denote the Lebesgue measure. We have to show that $\mu(E) = 0$. Assume instead that $\mu(E) > 0$, we can suppose without loss of generality that $\mu(E) < +\infty$. Let A, B be disjoint compact sets of positive Lebesgue measure included in E , these sets exist in view of Theorem 2.14 in Rudin [141] (Riesz Representation Theorem). We consider the function $\phi(x) = \mathbf{1}(x \in A) - s\mathbf{1}(x \in B)$, $s > 0$.

Let $f_1^\epsilon(x) = f_1(x) + \epsilon\phi(x)$, $f_2^\epsilon(x) = f_2(x) - \epsilon\phi(x)$ and $f_i^\epsilon(x) = f_i(x)$ for $i \notin \{1, 2\}$. If $\epsilon > 0$ is small enough, f^ϵ and $f^{-\epsilon}$ are in \mathcal{F} and for $i \in \{1, 2\}$:

$$\rho_i(f^{\pm\epsilon}) = \rho_i(f) \pm \epsilon\rho_i(\phi) = \rho \pm \epsilon\rho_i(\mathbf{1}_A) \mp s\epsilon\rho_i(\mathbf{1}_B).$$

Since $f \in \mathcal{F}^*$, $\max(\rho_1(f^{\pm\epsilon}), \rho_2(f^{\pm\epsilon})) \geq \rho$ and we deduce that $\text{sign}(\rho_1(\phi)) = \text{sign}(\rho_2(\phi))$, where sign is the sign function ($\text{sign}(0) = 0$, and for $x \neq 0$, $\text{sign}(x) = \frac{x}{|x|}$). It follows that for all real s , $\rho_1(\mathbf{1}_A) - s\rho_1(\mathbf{1}_B)$ and $\rho_2(\mathbf{1}_A) - s\rho_2(\mathbf{1}_B)$ have the same sign. Therefore the vectors $(\rho_1(\mathbf{1}_A), \rho_1(\mathbf{1}_B))$ and $(\rho_2(\mathbf{1}_A), \rho_2(\mathbf{1}_B))$ are colinear: there exists $C_{A,B}$ such that:

$\rho_1(\mathbf{1}_A) = C_{A,B}\rho_2(\mathbf{1}_A)$: $C_{A,B}$ cannot depend on B and by symmetry does not depend neither on A . Thus, exists $C > 0$ such that:

$$\rho_1(\mathbf{1}_A) = C\rho_2(\mathbf{1}_A).$$

This last equality has been proved for any compact set included in E . From Theorem 2.14 in [141], it can be extended to any Borel set included in E . Thus, for all $A \subset E$ with $\mu(A) > 0$, $\frac{1}{\mu(A)} \int_A \frac{E_A^{0,x}(\sigma_{0,x})}{p_1 r_1(x)} - C \frac{E_A^{0,x}(\sigma_{0,x})}{p_2 r_2(x)} dx = 0$. We can apply Theorem 1.40 of [141] and conclude that a.e. in E :

$$C' r_1(x) = r_2(x).$$

This contradicts our hypothesis on the processing rates and therefore $\mu(E) = 0$. We have proved that there exists f in \mathcal{F}^* such that a.e. $f_j(x) = \mathbf{1}(x \in V_j)$ and $\mu(V_j \cap V_k) = 0$ for $j \neq k$. We deduce that $(\mathbf{1}(V_j))_{j \in \mathcal{J}}$ is a tessellation in \mathcal{F}^* . \square

6.4.2 Cellular Policies

Let $\{V_j\}, j \in \mathcal{J}$, be a tessellation, a *cellular policy* with cells $\{V_j\}_j$ is a policy scheme satisfying for all j and $m \in \mathcal{M}$: $\pi_j(m)(\mathbb{R}^d \setminus V_j) = 0$. From Proposition 6.4.2, cellular policies reach the stability region under some assumptions. We say that a cellular policy is *work-conserving* if $m(V_j) > 0$ implies $\pi_j(m)(V_j) = 1$.

Proposition 6.4.3 *Let $\{V_j\}, j \in \mathcal{J}$, be a tessellation with bounded sets, any work conserving cellular policy with cells $\{V_j\}_j$ is stable if:*

$$\forall j, \int_{V_j} \frac{E_A^{0,x}(\sigma_{0,x})}{r_j(x)} \lambda(dx) < p_j.$$

If there is a j such that: $\int_{V_j} \frac{E_A^{0,x}(\sigma_{0,x})}{r_j(x)} \lambda(dx) > p_j$ then any cellular policy with cells $\{V_j\}_j$ is unstable.

This proposition is analog to the result on a single server queue which asserts that the stability does not depend on the discipline, provided it is work-conserving. There is no interaction between server stations when a cellular policy is used, hence it is sufficient to prove the following: *suppose that the intensity measure λ is finite and that there is a unique server. If $A \in \mathcal{N}^s$ then any work conserving policy is stable, if $A \notin \bar{\mathcal{N}}^s$ any working policy is unstable.* This result on multi-class queues is mainly known. For the sake of completeness, we give a proof of this fact.

When there is only one server in the system, the system reduces to a multi-class queue. So the condition $\lambda \in \mathcal{N}^s$ is restated as:

$$\int_{\mathbb{R}^d} \frac{E_A^{0,x}(\sigma_{0,x})}{r(x)} \lambda(dx) < p,$$

where r is the processing rate for the server providing service for a user located at x and p is the expectation of the available processing power.

Proposition 6.4.4 *Suppose that the intensity measure $\lambda(dx)$ is finite and that there is a unique server. If $A \in \mathcal{N}^s$ then any work conserving policy is stable.*

Proof. Since λ is a finite Radon measure, $N = \sum_n \delta_{\{T_n, \frac{\sigma_n}{r(X_n)}\}}$ is a simple marked point process on \mathbb{R} with finite intensity $E(N[0, 1]) = \int_{\mathbb{R}^d} \lambda(dx)$. For a given work conserving policy π , define $Y_t = \int_{\mathbb{R}^d} \frac{W_t(dx)}{r(x)}$. From Equation (6.5), we deduce that for $t \in [T_n, T_{n+1})$: $Y_t = \left(Y(T_n-) + \frac{\sigma_n}{r(X_n)} - \int_{T_n}^t \epsilon(t) dt \right)^+$. Y_t does not depend on the policy and Y_t is the usual workload for $G/G/1$ queue. The workload for this queue is equal to $\int_{\mathbb{R}^d} \lambda(dx) E_N^0(\frac{\sigma_0}{r(X_0)}) = \int_{\mathbb{R}^d} \frac{E_A^{0,x}(\sigma_0, x)}{r(x)} \lambda(dx) < p$. Similarly, we define $W_n = W_{T_n-}$ and it appears that $(W_n), n \geq 0$, is generated by a stochastic recurrence, see [42], [20].

If W_0 is an atomic measures with a finite set of atoms on \mathbb{R}^d then a.s. so is W_t for $t \geq 0$. We define the following policy on atomic measures with a finite set of atoms:

$$\pi^-(m) \mapsto \begin{cases} \epsilon \delta_{x^-} & \text{if } m \neq 0 \\ 0 & \text{if } m = 0. \end{cases}$$

where $x^- = \arg \min\{x : \mathbf{1}(m(\{x\}) > 0)r(x)\}$. If multiple choices of x^- are possible, we choose the first in the lexicographic order. π^- is the work conserving policy which dedicates all the processing power to the slowest customer. π^- is monotone and $M_t^-(B) \leq M_t^-(\mathbb{R}^d)$. As already pointed, $M_t^-(\mathbb{R}^d)$ is the Loynes' sequence for the usual stable $G/G/1$ queue. From Lemmas 6.3.1, 6.3.2, we deduce that M_t^- converges a.s. toward the Loynes' variable M_∞^- .

Consider now any work conserving policy π , we define similarly the Loynes' variable M_t for policy π , $M_t(\mathbb{R}^d) \leq M_t^-(\mathbb{R}^d) \leq M_\infty^-(\mathbb{R}^d)$. The event $A = \{M_{T_n}^- = 0\}$ is a renovating event for M_{T_n} and since the workload of the $G/G/1$ queue is strictly less than 1, $P_N^0(A) \geq P_N^0(M_\infty^-(\mathbb{R}^d) = 0) > 0$. From Theorem 2.5.3 and Property 2.5.5 of [20], we deduce that M_t converges to a stationary solution M_∞ and that M_t couples with M_∞ (in the strong backward sense). \square

Restating Property 2.4.1 of [20], we can also prove that from any finite initial condition m , W_t^m couples with $M_\infty \circ \theta_t$ (as t tends toward $+\infty$). \square

6.4.3 Homogeneous Networks

In this subsection, we establish the stability region in the wireless communication scenario (example 6.1.3).

Spatially Ergodic Network.

The arrival point process A is supposed to be stationary in time and space. The intensity of A is denoted by λ and $E_A^{0,x}(\sigma_0, x) = \sigma$. We assume that the attenuation function is radial and positive: $L(x, Y_j) = l(|Y_j - x|)$ with $r \mapsto rl(r) \in L^1(\mathbb{R}_+)$. We assume that the point pattern $\{Y_j\}_{j \in \mathbb{N}}$ is a realization of an ergodic point process on the plane \mathbb{R}^2 of intensity $\nu > 0$. From Campbell's Formula, we have: $EI(x) = \nu \int_{\mathbb{R}_+} rl(r) dr < +\infty$. The stability of the system relies on:

$$\rho_c^{-1} = \inf_{f \in \mathcal{F}} \sup_{j \in \mathbb{N}} \int_{\mathbb{R}^2} \frac{f_j(x) I(x)}{l(|x - Y_j|)} dx.$$

If $\lambda\sigma < \rho_c$ the system is stable, if $\lambda\sigma > \rho_c$ the system is unstable.

Lemma 6.4.5 ρ_c is a.s. constant.

Proof. $(f_j)_{j \in \mathbb{N}} \mapsto (f_j(\cdot - y))_{j \in \mathbb{N}}$ is a bijection on \mathcal{F} . It follows that for all y , ρ is invariant under translations by y . Thus, for all $a \geq 0$, from ergodicity, $P(\rho > a) \in \{0, 1\}$. \square

Honeycomb Network.

The server stations are located on a regular hexagonal grid of radius R . We index the server stations by \mathbb{Z}^2 and with a complex representation of \mathbb{R}^2 , the server station (p, q) is located at $Y_{p,q} = R(p + qe^{i\frac{\pi}{3}})$. Let $\{V_j\}, j \in \mathbb{Z}^2$, be the associated Voronoi tessellation: $x \in V_j$ if for all $j' \neq j$, $|x - Y_j| < |x - Y_{j'}|$. A simple argument on the symmetry of the hexagonal grid leads to the following proposition which implies that the Voronoi cellular network is optimal for the honeycomb grid.

Proposition 6.4.6 *For the honeycomb network,*

$$\rho_c^{-1} = \int_{V_{0,0}} \frac{I(x)}{l(|x|)} dx.$$

Poisson Network.

We turn to the analysis of the stability region when the server stations are located more randomly. We now assume that the server stations are located according to a realization of a Poisson Process of finite intensity $\nu > 0$.

Proposition 6.4.7 *We assume that $\limsup_{r \rightarrow +\infty} \frac{l(4r)}{l(r)} > 0$, l is non-increasing and $r^2 l(r) \in L^1(\mathbb{R}_+)$. If $\{Y_j\}_{j \in \mathbb{N}}$ is an homogeneous Poisson point process of finite intensity $\nu > 0$ then a.s. $\rho_c = 0$.*

Thus, in the homogeneous Poisson case, the system cannot be stable. Note that if $l(r) = \min(1, r^{-\alpha})$, $\alpha > 3$, the assumptions of the proposition hold. Whatever the intensity of the base stations is, a local behavior of the Poisson point pattern will lead to a global instability. This negative result is similar to the results in the static case obtained, see the forthcoming Theorem 7.3.14. The assumptions of this proposition are not optimal, in particular the number 4 is arbitrary and the assumption on the monotony of l can easily be relaxed.

Proof. Suppose $\rho_c > 0$ and let $B(0, R)$ denote the open ball of radius R with center 0. We define the annulus $\mathcal{A}_n = B(0, (n+1)R) \setminus B(0, nR)$. The area of \mathcal{A}_n is $|\mathcal{A}_n| = (2n+1)\pi R^2$. Let $\theta > e^2 \nu$ and $S_R = \frac{\theta}{\rho_c} \sum_{n \geq 4} |\mathcal{C}_n| \frac{l((n-1)R)}{l(4R)} < \infty$.

For a Poisson point process Φ , the event:

$$\Omega_R = \{\Phi(B(0, 2R)) = 0\} \cap \{\Phi(\mathcal{A}_2) > 2S_R\} \cap_{n > 2} \{\Phi(\mathcal{A}_n) \leq \theta |\mathcal{C}_n|\}$$

has positive probability. Indeed, the sets \mathcal{A}_n are disjoint and using Lemma 1.2 of [129]:

$$P(\cap_n \Phi(\mathcal{A}_n) \leq \theta |\mathcal{A}_n|) = \prod_n P(\Phi(\mathcal{A}_n) \leq \theta |\mathcal{A}_n|) > 0$$

On Ω_R , for $x \in B(0, R)$ we have $I(x) = \sum_j l(|x - Y_j|) \geq \Phi(\mathcal{A}_2) l(4R)$. Moreover if $Y_j \in \mathcal{C}_n$, since $\int_{B(0,R)} f_j(x) \frac{I(x)}{l(|x - Y_j|)} dx \leq \rho_c^{-1}$,

$$\int_{B(0,R)} f_j(x) dx \leq \frac{1}{\Phi(\mathcal{A}_2) \rho_c} \frac{l((n-1)R)}{l(4R)}. \quad (6.17)$$

It follows:

$$\begin{aligned} \sum_j \mathbf{1}(|Y_j| \geq 3R) \int_{B(0,R)} f_j(x) dx &= \sum_{n > 2} \sum_{Y_j \in \mathcal{A}_n} \int_{B(0,R)} f_j(x) dx \\ &\leq \frac{\theta}{\Phi(\mathcal{A}_2) \rho_c} \sum_n |\mathcal{A}_n| \frac{l((n-1)R)}{l(4R)} \\ &\leq \frac{1}{2}. \end{aligned}$$

Since $\sum_j \int_{B(0,R)} f_j(x) dx = \pi R^2$ and $\Phi(B(0, 2R)) = 0$, we deduce:

$$\sum_j \mathbf{1}(Y_j \in \mathcal{A}_2) \int_{B(0,R)} f_j(x) dx \geq \frac{\pi R^2}{2}.$$

Using this last equation with Equation (6.17) for $n = 2$, we obtain:

$$\rho_c \leq \frac{l(R)}{l(4R)} \frac{2}{\pi R^2}.$$

From the hypothesis on l , for R large enough, we find a contradiction. We have done our reasoning on the event Ω_R , since $P(\Omega_R) > 0$, by ergodicity of the Poisson point process, the result is extended on the whole σ -algebra. \square

Chapter 7

Spatial Capacity of Wireless Networks

Résumé Dans ce chapitre nous étudions un modèle de macrodiversité dans les réseaux CDMA (Code Division Multiple Access). Les différences entre la voie montante (de l'utilisateur vers la station de base) et la voie descendante (de la station de base vers l'utilisateur) aboutissent à deux modèles différents qui sont étudiés en parallèle. Pour satisfaire les demandes des usagers en terme de débit, il est nécessaire de mettre en oeuvre une politique de contrôle des puissances des signaux émis. Dans le cas d'un réseau fini sur la voie descendante, on démontre une condition nécessaire sur la politique optimale d'allocation des puissances. Ce résultat montre que la macrodiversité sur la voie descendante a une influence limitée. L'étude des réseaux infinis se conduit dans le cadre des processus stationnaires ergodiques. Sur la voie montante, il existe une condition nécessaire et suffisante d'existence d'une allocation de puissance permettant de satisfaire les usagers. Cette condition est du type " $\rho < 1$ ", où ρ n'est fonction que de la demande moyenne de débit et du nombre moyen par unité de surface des usagers et des stations de base. Sur la voie descendante, à l'inverse, il est démontré que si les usagers sont répartis dans l'espace suivant des réalisations d'un processus de Poisson homogène, alors il n'existe presque sûrement pas de politique de contrôle de puissance qui permette de satisfaire toutes les demandes des usagers. Enfin, dans un scénario dynamique nous montrons comment il est possible d'appliquer les résultats du Chapitre 6 à la macrodiversité dans les réseaux sans-fils sur la voie descendante.

Abstract In this chapter we define and analyze a general model of macrodiversity in CDMA networks (Code Division Multiple Access). Some differences between the uplink (from users to base stations) and downlink (from base stations to users) lead to two different models which are studied in parallel. In order to satisfy the bit rate requirements of users, it is necessary to enforce a control policy of emitted powers. For a finite network on the downlink, we prove a necessary condition on the optimal power allocation policy. This result shows that macrodiversity has a limited impact on the downlink. The analysis of infinite networks is led in the framework of stationary ergodic point processes. On the uplink, there is a necessary and sufficient condition on the existence of a power allocation which guarantee a given set of bit rate requirements for users. This condition is of type " $\rho < 1$ ", where ρ depends on the average bits rate requirement of users and on the average number per unit of surface of users and base stations. On the contrary, on the downlink, it is proven that if the location of users in space is a realization of a homogeneous Poisson point process, then almost surely there is no power allocation which satisfies all the users' demands. Finally in a dynamic scenario we show that it is possible to apply the results of Chapter 6 to the wireless networks in macrodiversity on the downlink.

7.1 Introduction

This chapter deals with the capacity of wireless multiple access networks. Primarily, it covers the analysis of CDMA networks (Code Division Multiple Access) in *macrodiversity*. In a network in macrodiversity the base stations are fully coordinated and they jointly code (for downlink) or decode (for uplink) the emitted signals. Macrodiversity networks supersedes the traditional *cellular* architecture of wireless networks where each user is attached to a unique base station based on its location. As an intermediate architecture, there are *load balanced* networks, where each user is attached to a unique base station but this allocation depends on the whole configuration of the network. Computing the load capacity of such networks is an important issue of wireless communications. This problem relies on finding a power allocation satisfying all users in the network.

The problem of power control and load constraints in CDMA networks has drawn much attention. However, most authors are only considering CDMA networks without macrodiversity. On the downlink in the seminal papers of Gilhousen et al. [72] and Zander [163], [162], the authors rely the solution of the power control problem to a condition of the type:

$$\rho(T) < 1, \quad (7.1)$$

where T is a square non negative matrix depending on the channel state and $\rho(T)$ denote the spectral radius of T . Baccelli et al. [15], [14] have developed a probabilistic geometric model to analyze the feasibility condition given by Equation (7.1). The users and the base stations are instances of spatial point processes and the authors compute the probability that a base station satisfies the SINR ratio requirement of each users in its cell. In this chapter, we extend the geometric model of Baccelli et al. to networks in macrodiversity.

On the uplink, Hanly [87], [88] has solved the power control problem for finite networks in macrodiversity. The solution of the power control problem reduces to a condition of the type:

$$\sum_{i=1}^M h_i < N, \quad (7.2)$$

where N and M are the numbers of base stations and users respectively and h_i is the SINR requirement of the i^{th} user. In the present chapter, we generalize the work of Hanly to infinite networks where users and base stations are instance of ergodic point processes.

The feasibility conditions given by Equations (7.1) and (7.2) can be understood as a condition of the type: " $\rho < 1$ " where ρ is the *load* of the network. In this chapter, we compute the value of the load both on uplink (denoted by ρ_{\uparrow}), and downlink (denoted by ρ_{\downarrow}) in a probabilistic setting where the channel condition depend on the relative positions of users and base stations. This modelling contribution will enable to understand better what is the impact of the geometry of the network in its capacity. On the uplink, if the mean SINR requirement is denoted by h , the mean number of users (respectively base stations) per surface unit is λ_u (resp. λ_s) we will obtain (Theorem 7.2.3):

$$\rho_{\uparrow} = h \frac{\lambda_s}{\lambda_u}, \quad (7.3)$$

$h\lambda_s$ is the mean SINR requirement per surface unit, so that the geometrical term of the uplink load reduces to $1/\lambda_u$.

On the downlink for a network with N base stations and M users, we will prove, for networks either cellular, load balanced or in macrodiversity, that the downlink load is asymptotically equal, as M grows large, to:

$$\rho_{\downarrow} \sim hM\gamma, \quad (7.4)$$

(Theorem 7.3.10) where γ is explicitly computed and depends on the relative position of the base stations.

Both Equations (7.3) and (7.4) show that the load may be decomposed as a mean SINR requirement per surface unit ($h\lambda_s$ on the uplink, hM on the downlink) and a geometric term ($1/\lambda_u$ on the uplink and γ on the downlink). This decoupling between mean SINR and geometry is of prime interest: given a required level of user quality of service, we can design a network architecture.

On the downlink, another consequence of our results is the comparison between the various possible levels of cooperation between base stations: macrodiversity, load balancing and cellular networks. We will hint that the main improvement between a fixed cell network and a macrodiversity network seems to be in the flexibility into affecting each user to a specific base station and not on the possibility to share a user between several base stations (Theorem 7.3.5). In other words, load balancing is as efficient as user sharing (i.e. macrodiversity). We will prove that the constant γ appearing in Equation (7.4) is the same for a network in macrodiversity, load balanced or for an optimal cellular network. On the contrary, as already known, for the uplink, macrodiversity has a much larger impact and appears as a major improvement compared to traditional cellular network structure.

In this chapter, we are primarily concerned by the impact of the locations of users and base stations on the capacity of the network. To this end, somewhat artificially, the path gain between a user located at x and a base station located at y will be set as $L(x, y)$. Averaging over the channel conditions we will often assume that the path gain depends only on the distance between x and y . This assumption is not meant to be realistic, however it captures the spatial features of wireless networks.

The remainder of this chapter is organized as follows. Section 7.2 is devoted to the macrodiversity on the uplink. In §7.2.1, we introduce our model, its key features are the spatial location of base stations and users, and the SINR requirements of each user. In §7.2.2 we extend Hanly's Theorem to ergodic spatial point processes of users and base stations and establish Equation (7.3).

In Section 7.3, we analyze the downlink. We present the model in §7.3.1 and establish a necessary and sufficient condition for the feasibility of the power control problem in §7.3.2. §7.3.3 gives a characterization of the optimal power allocation. This characterization establishes a bound on the increase of capacity brought by macrodiversity in a network. In §7.3.5, we pay attention to the limit downlink load as the number of users grows large and we establish Equation (7.4). In §7.3.7 we extend our results to infinite networks and prove a negative result for the feasibility of power control problem when the point process of users is a Poisson point process.

At last, in Section 7.4, we propose a dynamic model where users arrive and leave the system after completion of a service. We show that this model is covered by our work in Chapter 6

7.2 Uplink

7.2.1 Model description

We consider a network consisting of M users and N base stations. The users are located at points $\{X_i\}_{1 \leq i \leq M} \in \mathbb{R}^2$ and the base station at points $\{Y_j\}_{1 \leq j \leq N} \in \mathbb{R}^2$. We denote by $U(x, y)$ the channel gain from y to x , $x, y \in \mathbb{R}^2$. $|U(x, y)|$ represents the path loss due to shadowing, fading and distance attenuation effects.

In an uplink multiple access network in macrodiversity, each user sends independently from the other a signal and the base stations are jointly decoding the received signals. This kind of channel is known as multi-receiver networks (see Hanly and Whiting [89]). A base sta-

tion j receives a signal equal to the sum of all the signals sent by the users plus an external white Gaussian noise. Let $w = (w_j)_{1 \leq j \leq N}$ denote the power of the noise vector, $U = (U(X_i, Y_j))_{1 \leq i \leq M, 1 \leq j \leq N}$, the channel matrix. The user i sends a signal s_i . Let $s = (s_i)_{1 \leq i \leq M}$ be the vector of the signal sent by users. Then mathematically the signals received by the base stations is a $\mathbb{R}^{M \times 1}$ vector:

$$v = U's + w.$$

We set the channel bandwidth to Δ Hz and we suppose that user i requires a rate R_i in bits per second. Let $S_i = E(|s_i|^2)$ and $\eta_j = E(|w_j|^2)$ denote the powers of the signals. If the users are sending their signals independently, it is known (see [89]) that the rate vector (R_1, \dots, R_M) is achievable if and only if there exists $S \in \mathbb{R}_+^M$ such that:

$$\forall i, \quad R_i \leq \Delta \log_2 \left(1 + \sum_{j=1}^N \frac{S_i |U(X_i, Y_j)|^2}{\eta_j + \sum_{m \neq i} S_m |U(X_m, Y_j)|^2} \right).$$

We restrain ourselves to the sufficient condition:

$$\forall i, \quad R_i \leq \Delta \log_2 \left(1 + \sum_{j=1}^N \frac{S_i |U(X_i, Y_j)|^2}{\eta_j + \sum_{m=1}^M S_m |U(X_m, Y_j)|^2} \right).$$

This last condition is only sufficient but when M is large it is expected not to be far from being necessary. Let $L(X_i, Y_j) = |U(X_i, Y_j)|^2$ denote the attenuation function. Thus, feasibility of a given rate vector is equivalent to a minimal requirement on the signal to interference ratio:

$$\forall i, \quad h_i \leq \sum_j \frac{L(X_i, Y_j) S_i}{\eta_j + \sum_m L(X_m, Y_j) S_m}, \quad (7.5)$$

where $h_i = 2^{R_i/\Delta} - 1$, with an abuse of language h_i will be called the SINR requirement of user i . The power allocation problem is stated as follows, for a given vector of bit rates $(R_i)_i$ does there exists a power vector $(S_i)_i$ such that the set inequalities (7.5) is satisfied. The following theorem solves the power allocation problem:

Theorem 7.2.1 (Hanly) Suppose that for all i, j , $L(X_i, Y_j) > 0$ and $\eta_j > 0$.

Then, there exists a solution of (7.5) if and only if

$$\sum_{i=1}^M h_i < N.$$

This theorem is surprising, since the feasibility condition does not rely on the geometry of the network (i.e. the coefficients $L(X_i, Y_j)$).

7.2.2 Stochastic Model

In this paragraph, we generalize the work done by Hanly in [87] for stochastic infinite networks. This generalization proves that Hanly's Theorem is not due to the finiteness of the network but is intrinsic to uplink communications in macrodiversity.

We follow the probabilistic setting of [15]. The set of users is a marked point process $\Pi_u = \{(X_i, h_i)\}_i$, where X_i is the location of the user i and h_i is its SINR requirement. We model similarly the base stations by a point processes on \mathbb{R}^2 : $\Pi_s = \{(Y_j, \eta_j)\}_j$, η_j is the noise power. We can suppose $\eta_j > 0$ and $h_i > 0$ for all i, j . Moreover, Π_u and Π_s are supposed to be a stationary and ergodic marked point processes. We denote by λ_u (resp. λ_s) the intensity of

Π_u (resp. Π_s) which are assumed to be finite. The Palm probability of the process Π_u (resp. Π_s) is denoted by P_u^0 (resp. P_s^0), (for an introduction to Palm probability, refer to Daley and Vere-Jones [55]). We assume that $E_u^0(h_0) < \infty$. We remind that $E_u^0(h_0)$ may be understood as the mean SINR requirement of typical user. At last, we consider a radial positive attenuation function, that is: $L(x, y) = l(|x - y|)$.

In infinite networks, the power control problem is still given by the set of inequalities (7.5). A SINR vector $(h_i)_{i \geq 0} > 0$ is feasible, if there exists a power allocation $(S_i)_{i \geq 0}$ such that the set of inequalities (7.5) is satisfied.

Following Hanly [87], we introduce:

$$G : \begin{cases} \mathbb{R}_+^{\mathbb{N}} & \rightarrow \mathbb{R}_+^{\mathbb{N}} \\ (S_i)_i & \mapsto \left(h_i \left(\sum_j \frac{L(X_i, Y_j)}{\eta_j + \sum_{m=0}^{\infty} S_m L(X_m, Y_j)} \right)^{-1} \right)_i \end{cases}$$

The power allocation problem is equivalent to finding $S \in \mathbb{R}_+^{\mathbb{N}}$ such that, component-wise: $G(S) \leq S$.

Lemma 7.2.2 With the foregoing assumptions, there exists a power allocation satisfying (7.5) with probability 0 or 1.

Proof. The event {Equation (7.5) has a solution} = {there exists S , such that $G(S) \leq S$ } is invariant under a translation on \mathbb{R}^2 since the value $G(S)$ does not change if we translate simultaneously all users and all base stations. Thus, by ergodicity, this event has probability 0 or 1. \square

We define the *uplink load* by:

$$\rho_{\uparrow} = \frac{\lambda_u}{\lambda_s} E_u^0(h_0). \quad (7.6)$$

The following result is a natural extension of Theorem 7.2.1.

Theorem 7.2.3 We assume that $E_s^0(\eta_0^{-1}) < +\infty$ and that one of the two following conditions holds:

- $x \mapsto xl(x)$ is in $L^1(\mathbb{R})$ and $x \mapsto xl(x)$ is non-increasing,
- or, there exists $\beta > 1$ such that $x \mapsto x^\beta l(x)$ is integrable.

then

- If $\rho_{\uparrow} > 1$, then (7.5) has almost surely no solution.
- If $\rho_{\uparrow} < 1$, then (7.5) admits almost surely a solution.

An analogy can be made between this theorem and the stability of G/G/s queues. The intensity of user arrival is λ_u , $\lambda_u E_u^0(h_0)$ is the mean SINR requirement per surface unit and λ_s plays the role of the number of service booths per surface unit. As for G/G/s queues, the limit case $\frac{\lambda_u}{\lambda_s} E^0(h_0) = 1$ is harder and the power allocation problem is not solved for these networks.

As for finite networks, The feasibility condition depends only on the bit rates requirement and the density of users and base stations in the network.

The technical hypothesis on $l(x)$ is used to ensure a rapid decay of the tail of the shot-noise process $\sum_i l(|X_i|)$. It covers a usual model for the attenuation function: $l(x) \sim x^{-\alpha}$, $\alpha > 2$. The assumption $E_s^0(\eta_0^{-1}) < +\infty$ simplifies the proof of the sufficient condition. The result should hold for weaker assumptions.

The proof of Theorem 7.2.3 is done in the next paragraph. The main idea is to follow the lines of the original proof of Theorem 7.2.1 and use ergodicity to ensure convergence and some uniform bounds on shot noise processes.

7.2.3 Proof of Theorem 7.2.3

The following lemma on shot noise processes is needed in the proof. In what follows, $|\cdot|$ is the Euclidean norm and $B(x, R)$ is the closed ball of center x and radius R .

Lemma 7.2.4 Let $\Pi = \{(X_i, Z_i)\}_i$ be a stationary marked point process on $\mathbb{R}^d \times \mathbb{R}_+$. We suppose Π has a finite intensity λ and $E^0(Z_0) < \infty$. Let $\alpha < 1$ and $x \mapsto l(x)$ a non-negative function on \mathbb{R} . If $x \mapsto x^{d-1}l(x)$ is integrable and $x \mapsto x^{d-1}l(x)$ is non-increasing on a neighborhood of $+\infty$, or if there exists $\epsilon > 0$ such that $x \mapsto x^{d-1+\epsilon}l(x)$ is integrable. Then, almost surely:

$$\liminf_{R \rightarrow +\infty} \sup_{x \in B(0, \alpha R)} \sum_{X_i \notin B(0, R)} Z_i l(|x - X_i|) = 0.$$

Proof. Suppose for example, $x \mapsto x^{d-1}l(x)$ is non-increasing on a neighborhood of $+\infty$. For n integer, let $C_n(R) = \{x \in \mathbb{R}^d : x \in B(0, (n+1)R) \setminus B(0, nR)\}$. We can write for all $x \in B(0, \alpha R)$:

$$\sum_{X_i \notin B(0, R)} Z_i l(|x - X_i|) \leq \sum_{n=1}^{\infty} l((n-\alpha)R) \sum_{X_i} Z_i \mathbf{1}_{X_i \in C_n(R)}.$$

If π_d denote the d -dimensional Lebesgue measure of the unit ball, from Campbell formuli, we deduce:

$$\begin{aligned} E \sup_{x \in B(0, \alpha R)} \sum_{X_i \notin B(0, R)} Z_i l(|x - X_i|) &\leq \lambda \sum_{n=1}^{\infty} l((n-\alpha)R) \int_{\mathbb{R}^d} \int_0^{+\infty} z \mathbf{1}_{x \in C_n(R)} P^0(dz) dx \\ &\leq \lambda \sum_{n=1}^{\infty} l((n-\alpha)R) E^0(Z_0) \pi_d R^d ((n+1)^d - n^d) \\ &\leq \lambda C R E^0(Z_0) \sum_{n=1}^{\infty} l((n-\alpha)R) R^{d-1} n^{d-1}, \end{aligned}$$

where C is a constant depending on the dimension d only. From the hypothesis on $x \mapsto x^{d-1}l(x)$, we can apply the dominated convergence theorem to conclude:

$$\lim_{R \rightarrow +\infty} E \sup_{x \in B(0, \alpha R)} \sum_{X_i \notin B(0, R)} Z_i l(|x - X_i|) = 0.$$

In order to get the result in almost sure convergence, it suffices to recall that from any sequence converging in L^1 , we can extract a sequence converging almost surely. We thus obtain the stated result. The case $x \mapsto x^{d-1+\epsilon}l(x)$ in $L^1(\mathbb{R})$ is similar. \square

The next lemma will be used to build a stationary solution. The proof is straightforward.

Lemma 7.2.5 With the hypothesis of Theorem 7.2.3, the mapping G as it is defined in §7.2.2 is continuous on $G^{-1}(\mathbb{R}_*^{+\mathbb{N}})$ for the L^∞ -norm: $\|S\| = \sup_{i \in \mathbb{N}} |S_i|$.

Proof of theorem 7.2.3. The idea is to follow the proof of Hanly in the finite case and use ergodicity and the uniform bound given by Lemma 7.2.4 to extend to infinite case.

Case $\rho_\uparrow > 1$.

Suppose that there exists a solution of (7.5) with a positive probability. From Proposition 7.2.2, this solution exists almost surely, we denote the solution by $S = (S_i)$. We have component-wise $G(S) \leq S$. Let $\underline{0} = (0)_{i \in \mathbb{N}}$, notice that almost surely for all i , $G(\underline{0})_i > 0$. The function G is

monotonous component-wise: if $S \leq S'$ then $G(S) \leq G(S')$. We deduce that $G(\underline{0}) \leq G(S) \leq S$ and for all i , $G^n(\underline{0})_i$ is an increasing sequence and is upper bounded by S_i . This sequence converges toward S_i^* , which by continuity (Lemma 7.2.5) satisfies $S^* = G(S^*)$. Since G is invariant under a translation, we can define a solution (S_i^*) as a mark on Π_u . For the sake of simplicity, we drop the "*" exponent in S^* and suppose directly $G(S) = S$, $S_i > 0$.

We consider the thinned point process: $\Pi_{u,t} = \sum_i \mathbf{1}_{S_i < t} \delta_{\{X_i, h_i, S_i\}}$, this marked point process is still stationary and ergodic. Let $\lambda_{u,t}$ be its intensity. The Palm probability of $\Pi_{u,t}$ is $P_{u,t}^0(\cdot) = P_u^0(\cdot | S_0 \in [0, t))$, (see Baccelli and Brémaud [20]). Let $\alpha < 1$, and, to simplify notations, let $N_R = \Pi_s(B(0, R))$, $M_R = \Pi_u(B(0, R))$ and $M_{t,R} = \Pi_{u,t}(B(0, R))$. Now, from the ergodicity of our model, almost surely:

$$\lim_{R \rightarrow +\infty} \frac{1}{N_R} \sum_{i=1}^{M_{\alpha R}} h_i = \rho_{\uparrow}, \text{ and } \lim_{R \rightarrow +\infty} \frac{M_{t, \alpha R}}{N_R} = \frac{\lambda_{u,t}}{\lambda_s} \alpha^2. \quad (7.7)$$

Let $Z_j = \eta_j^{-1}$, now, from Lemma 7.2.4, almost surely:

$$\liminf_{R \rightarrow +\infty} \sup_{X_i \in B(0, \alpha R)} \sum_{Y_j \notin B(0, R)} Z_j l(|X_i - Y_j|) = 0. \quad (7.8)$$

The integrability of $E_u^0(h_0)$ implies that $\lim_{t \rightarrow +\infty} E_u^0(h_0 \mathbf{1}(h_0 \geq t)) = 0$. This last limit implies thanks to ergodicity and an exchange of limit (justified by Fubini's Theorem):

$$\lim_{t \rightarrow \infty} \lim_{R \rightarrow \infty} \frac{1}{N_R} \sum_{i=1}^{M_{\alpha R}} h_i \mathbf{1}(h_i \geq t) = 0. \quad (7.9)$$

Then we do the following decomposition:

$$\frac{1}{N_R} \sum_{i=1}^{M_{\alpha R}} h_i = \frac{1}{N_R} \sum_{X_i \in \Pi_u^t \cap B(0, \alpha R)} h_i + \frac{1}{N_R} \sum_{i=1}^{M_{\alpha R}} h_i \mathbf{1}(h_i \geq t). \quad (7.10)$$

The first term of the right hand side of Equation (7.10), say A , is upper bounded by:

$$\begin{aligned} A &= \frac{1}{N_R} \sum_{X_i \in \Pi_u^t \cap B(0, \alpha R)} \sum_{j=1}^{\infty} \frac{S_i L(X_i, Y_j)}{\eta_j + \sum_{m=1}^{\infty} S_m L(X_m, Y_j)} \\ &\leq \frac{1}{N_R} \sum_{X_i \in \Pi_u^t \cap B(0, \alpha R)} \sum_{j=1}^{N_R} \frac{S_i L(X_i, Y_j)}{\eta_j + \sum_{m=1}^{\infty} S_m L(X_m, Y_j)} \\ &\quad + \frac{1}{N_R} \sum_{X_i \in \Pi_u^t \cap B(0, \alpha R)} \sum_{Y_j \notin B(0, R)} t Z_j l(|X_i - Y_j|) \\ &\leq 1 + t \frac{M_{\alpha R}^t}{N_R} \sup_{X_i \in B(0, \alpha R)} \sum_{Y_j \notin B(0, R)} Z_j l(|X_i - Y_j|). \end{aligned}$$

We can compute the $\liminf_{R \rightarrow \infty}$ of Equation (7.10) on both side and then let t tends to infinity. From Equation (7.7), the left hand side of the previous inequality converges to ρ_{\uparrow} whereas from Equations ((7.7), (7.8) and (7.9), the right hand side is bounded by 1 (by letting t tends to infinity). Thus $\rho_{\uparrow} \leq 1$ is a necessary condition of the feasibility of the power allocation problem.

Case $\rho_{\uparrow} < 1$ and $h_i < h$ for all i .

The central argument of Hanly is a change of variables and an application of Brouwer's fixed point theorem (see Goebel and Kirk [75]). Hanly defines:

$$g : \begin{cases} \bigotimes_{i \in \mathbb{N}} (h_i, +\infty] & \rightarrow \mathbb{R}^{+\mathbb{N}} \\ (t_i)_{i \in \mathbb{N}} & \mapsto \left(\frac{h_i}{t_i - h_i}\right)_i \end{cases},$$

and

$$f_i : \begin{cases} \mathbb{R}^{+\mathbb{N}} & \rightarrow \mathbb{R}^+ \\ (S_m)_{m \in \mathbb{N}} & \mapsto \sum_{j=1}^{\infty} \frac{(S_i+1)L(X_i, Y_j)}{\eta_j + \sum_{m=1}^{\infty} S_m L(X_m, Y_j)}. \end{cases}$$

Let $\epsilon > 0$ and define:

$$\phi^\epsilon : \begin{cases} \bigotimes_{i \in \mathbb{N}} [h_i(1 + \epsilon), \frac{1}{\epsilon}] & \rightarrow \bigotimes_{i \in \mathbb{N}} [h_i(1 + \epsilon), \frac{1}{\epsilon}] \\ (t_i)_{i \in \mathbb{N}} & \mapsto (\Phi_i^\epsilon(t))_{i \in \mathbb{N}} \end{cases},$$

where:

$$\Phi_i^\epsilon(t) = \begin{cases} f_i \circ g_i(t_i) & \text{if } f_i \circ g(t) \in [h_i(1 + \epsilon), \frac{1}{\epsilon}] \\ h_i(1 + \epsilon) & \text{if } f_i \circ g(t) < h_i(1 + \epsilon) \\ \frac{1}{\epsilon} & \text{if } f_i \circ g(t) > \frac{1}{\epsilon} \end{cases}$$

From Assumption $E_s^0(\eta_0^{-1}) < +\infty$ and Lemma 7.2.4, it is easy to see that f_i is continuous on $\bigotimes_{i \in \mathbb{N}} [\frac{h_i}{\epsilon^{-1} - h_i}, \frac{1}{\epsilon}]$ for the L^∞ -norm. Thus, ϕ^ϵ is a continuous map. $\bigotimes_{i \in \mathbb{N}} [h_i(1 + \epsilon), \frac{1}{\epsilon}]$ is a compact convex set and hence by Brouwer's fixed point theorem: there exists t^ϵ such that $\phi^\epsilon(t^\epsilon) = t^\epsilon$. We will first show that we can extract a converging sequence from t^ϵ .

We consider the thinned point process: $\Pi_s^{q,w} = \sum_j \mathbf{1}_{\eta_j > w} \mathbf{1}_{\sum_i l(|X_i - Y_j|) < q} \delta_{\{Y_j, \eta_j\}}$, this point process is still stationary and ergodic. Let $\lambda_s^{q,w}$ be its intensity. Since, $\sum_j l(|X_i - Y_j|)$ is almost surely finite for all j and $\eta_j > w$, for q large and w small, we still have:

$$\frac{\lambda_u}{\lambda_s^{q,w}} E_u^0(h_0) > 1,$$

thus we can suppose directly that $\sum_i l(|X_i - Y_j|) < q$ and $\eta_j > w$ for all j .

Let $a > h$ large enough to guarantee: $\frac{h}{a-h} \frac{q}{w} < a$ and suppose $t_i^\epsilon \geq a$. Then $S_i^\epsilon = (g(t^\epsilon))_i \leq \frac{h_i}{a-h_i}$. Hence $a \leq t_i^\epsilon \leq f_i(S^\epsilon) \leq \frac{h_i}{a-h_i} \sum_j \frac{L(X_i, Y_j)}{\eta_j} < a$. Thus, we have proved: for all i , $t_i^\epsilon \in [h_i, a]$. We thus can extract a sequence t^ϵ converging toward $t \in \bigotimes_{i \in \mathbb{N}} [h_i, a]$. We now want to show that $\lim_{\epsilon \rightarrow 0} g(t^\epsilon)$ exists. To do so, we prove that for all i , there exists ϵ_i such that for all $\epsilon < \epsilon_i$, t_i^ϵ satisfies: $t_i^\epsilon > h_i(1 + \epsilon_i)$.

Suppose that for some i , for all $\eta > 0$, there exists $\epsilon < \eta$ such that: $t_i^\epsilon = h_i(1 + \epsilon)$. We consider a sequence of such ϵ . Let $S_m^\epsilon = (g(t^\epsilon))_m$ and $I_j^\epsilon = \sum_m S_m^\epsilon L(X_m, Y_j)$, the interference at base station j . We have $I_j^\epsilon \geq \epsilon^{-1} L(X_i, Y_j)$, thus for all j : $\lim_{\epsilon \rightarrow 0} I_j^\epsilon = +\infty$. Since $t_k^\epsilon = \max(\sum_j \frac{(S_k^\epsilon+1)L(X_k, Y_j)}{\eta_j + I_j^\epsilon}, h_k(1 + \epsilon))$, by a dominated convergence argument we deduce that S_k^ϵ cannot be bounded, hence for all k :

$$\lim_{\epsilon \rightarrow 0} t_k^\epsilon = h_k.$$

Since $\rho_\uparrow < 1$, there exists $\alpha > 1$ such that:

$$\frac{\lambda_u \alpha^2}{\lambda_s} E_u^0(h_0) < 1.$$

Thus, ergodicity implies:

$$\lim_{\epsilon \rightarrow 0} \lim_R \frac{1}{N_R} \sum_{i=1}^{M_{\alpha R}} t_i^\epsilon = \frac{\lambda_u \alpha^2}{\lambda_s} E_u^0(h_0) < 1. \quad (7.11)$$

Since t^ϵ is a fixed point, we have for $\epsilon < a^{-1}$:

$$\frac{1}{N_R} \sum_{i=1}^{M_{\alpha R}} t_i^\epsilon = \frac{1}{N_R} \sum_{i=1}^{M_{\alpha R}} \phi_i^\epsilon(t^\epsilon) \geq \frac{1}{N_R} \sum_{i=1}^{M_{\alpha R}} f_i \circ g(t^\epsilon), \quad (7.12)$$

We write:

$$\begin{aligned} & \frac{1}{N_R} \sum_{i=1}^{M_{\alpha R}} f_i \circ g(t^\epsilon) \\ & \geq \frac{1}{N_R} \sum_{i=1}^{M_{\alpha R}} \sum_{j=1}^{N_R} \frac{L(X_i, Y_j)(S_i^\epsilon + 1)}{\eta_j + I_j^\epsilon} \\ & \geq \frac{1}{N_R} \sum_{j=1}^{N_R} \frac{I_j^\epsilon + \sum_i L(X_i, Y_j)}{\eta_j + I_j^\epsilon} \\ & \quad - \frac{1}{N_R} \sum_{j=1}^{N_R} \sum_{X_i \notin B(0, \alpha R)} \frac{L(X_i, Y_j)(\epsilon^{-1} + 1)}{w} \\ & \geq \frac{1}{N_R} \sum_{j=1}^{N_R} \frac{I_j^\epsilon + \sum_i L(X_i, Y_j)}{\eta_j + I_j^\epsilon} \\ & \quad - \sup_{y \in B(0, R)} \sum_{X_i \notin B(0, \alpha R)} \frac{L(X_i, y)(\epsilon^{-1} + 1)}{w}. \end{aligned}$$

Now, by letting R tend toward infinity, using Lemma 7.2.4, we obtain:

$$\liminf_{R \rightarrow +\infty} \frac{1}{N_R} \sum_{i=1}^{M_{\alpha R}} f_i \circ g(t^\epsilon) \geq \lim_R \frac{1}{N_R} \sum_{j=1}^{N_R} \frac{I_j^\epsilon + \sum_i L(X_i, Y_j)}{\eta_j + I_j^\epsilon},$$

We can apply the ergodic theorem for point processes (see [55]):

$$\liminf_{R \rightarrow +\infty} \frac{1}{N_R} \sum_{i=1}^{M_{\alpha R}} f_i \circ g(t^\epsilon) \geq E_s^0\left(\frac{I_0^\epsilon}{\eta_0 + I_0^\epsilon}\right) + E_s^0\left(\frac{\sum_i L(X_i, 0)}{\eta_0 + I_0^\epsilon}\right),$$

letting ϵ tend toward 0 and using the dominated convergence theorem, we conclude that:

$$\lim_{\epsilon \rightarrow 0} \liminf_{R \rightarrow +\infty} \frac{1}{N_R} \sum_{i=1}^{M_{\alpha R}} f_i \circ g(t^\epsilon) \geq 1.$$

This last inequality together with (7.12) contradicts (7.11). Thus we cannot have $t_i^\epsilon = h_i(1 + \epsilon)$ an infinite number of times. We have proved that for $\epsilon < \epsilon_i$, $t_i^\epsilon > h_i(1 + \epsilon_i)$. Since $g_i(t) = \frac{h_i}{t - h_i}$ is a continuous map on $[h_i(1 + \epsilon_i), a]$, we can define: $S_i^* = g_i(t_i) = \lim_{\epsilon \rightarrow 0} g_i(t_i^\epsilon)$. From the continuity of f_i :

$$f_i(S^*) = h_i \frac{S_i^* + 1}{S_i^*},$$

which is equivalent to:

$$h_i = \sum_{j=1}^{\infty} \frac{S_i^* L(X_i, Y_j)}{\eta_j + \sum_{m=1}^{\infty} S_m^* L(X_m, Y_j)}.$$

This concludes the proof of the theorem when $h_i < h$ for all i .

Case $\rho_\uparrow < 1$, general case.

Let $h > 0$, we consider a new user point process: $\Pi'_u = \sum_i \lceil \frac{h_i}{h} \rceil \delta_{\{X_i, h \lceil \frac{h_i}{h} \rceil^{-1}\}}$. Since, by hypothesis, the marked point process $\{(X_i, h_i)\}$ is ergodic, Π'_u is a stationary ergodic marked point process, its marks: $h \lceil \frac{h_i}{h} \rceil^{-1}$ are upper bounded by h . Moreover, if we find a power allocation satisfying (7.5) for Π'_u , by additivity of (7.5), we have found a solution of (7.5) for Π_u . A direct computation shows that $\lambda'_u \leq \lambda_u(\frac{E_u^0(h_0)}{h} + P_u^0(h_0 \geq h))$. Hence for h large enough, $\frac{\lambda'_u}{\lambda_s} E_{u'}^0(h_0) < 1$. This concludes the proof in the general case. \square

7.3 Downlink

7.3.1 Model Description

We consider the same network as in the previous section, with the same notations. There are M users and N base stations. In a downlink multiple access network in macrodiversity, the base stations are jointly coding a signal for each user and users are decoding independently. This kind of channel is known as multiple input multiple output (MIMO) broadcast channel (see in particular Caire and Shamai [46], Goldsmith, Jindal and Vishwanath [77]). A user i receives a signal equal to the sum of all the signals sent by the base stations plus an external white Gaussian noise. As above, $w = (w_i)_i$ denote the noise vector, $U = (U(X_i, Y_j))_{i,j}$, the channel matrix and $U_i = (U(X_i, Y_j))_j$ the channel vector to i . The base station j sends a signal s_{ij} to the user i . Let $s_i = (s_{ij})_j$ be the vector of the signal sent to i . Then the signals received by users is a vector of size N equal to

$$u = U \sum_{i=1}^M s_i + w,$$

Let Γ_i be the covariance matrix of $(s_{ij})_{1 \leq j \leq N}$ and $\eta_i = E(|w_i|^2)$ the power of the noise at i . User i requires a rate R_i in bits per second. If we make the assumption, that for all j , for all $m \neq i$, the signals s_{mj} are regarded as noise by the base stations in the coding of signal s_i , the gaussian channel capacity theorem (refer to Cover and Thomas [49]) implies that the rate vector $R = (R_1, \dots, R_M)$ is achievable if:

$$\forall i, \quad R_i \leq \Delta \log_2 \left(1 + \frac{U_i^* \Gamma_i U_i}{\eta_i + U_i^* \sum_{m \neq i} \Gamma_m U_i} \right). \quad (7.13)$$

(This last condition is only sufficient and it is not necessary.) In this work, we only consider achievable rates satisfying in Equation (7.13) in the case where Γ_i is diagonal: the base stations are sending uncorrelated signals to each user. This is a natural assumption for an efficient coding. We note $S_{ij} = \Gamma_i(j, j)$ and $l_{ij} = L(X_i, Y_j) = |U(X_i, Y_j)|^2$ the attenuation function. Thus the rate vector $R = (R_1, \dots, R_M)$ is achievable if there exists a power allocation (S_{ij}) such that:

$$\forall i, \quad R_i \leq \Delta \log_2 \left(1 + \frac{\sum_j L(X_i, Y_j) S_{ij}}{\eta_i + \sum_j L(X_i, Y_j) \sum_{m \neq i} S_{mj}} \right),$$

thus, letting $h_i = 1 - 2^{-R_i/\Delta}$, feasibility of a given rate vector is equivalent to the existence a power allocation (S_{ij}) such that:

$$\forall i, \quad h_i \leq \frac{\sum_j L(X_i, Y_j) S_{ij}}{\eta_i + \sum_j L(X_i, Y_j) \sum_m S_{mj}}. \quad (7.14)$$

The set of inequalities (7.14) is our macrodiversity model for multiple access downlink networks. Note that the definition of the SINR $h_i = 1 - 2^{-R_i/\Delta}$ is not consistent with the

definition of h_i on the uplink (that is $h_i = 2^{R_i/\Delta} - 1$). However since they will play exactly the same role, we use the same notation for these two scalars, in the limit Δ large, they are equivalent.

7.3.2 Power Allocation Algebras

In this section, we study the power allocation problem (7.14), following Baccelli, Blaszczyzyn and Tournois [15].

We introduce the set of stochastic matrices:

$$\mathcal{A} = \{A = (a_{ij}) \in \mathbb{R}^{M \times N}, A \geq 0, \forall i \sum_j a_{ij} = 1\}.$$

A matrix A in \mathcal{A} will be called an allocation matrix.

The following obvious lemma restates Equation (7.14).

Lemma 7.3.1 An power allocation $(S_{ij})_{1 \leq i \leq M, 1 \leq j \leq N}$ is a solution of (7.14) if and only if there exists a non-negative matrix $A \in \mathcal{A}$ such that:

$$\forall i, j \quad a_{ij} h_i \leq \frac{L(X_i, Y_j) S_{ij}}{\eta_i + \sum_j L(X_i, Y_j) \sum_m S_{mj}}. \quad (7.15)$$

For a fixed $A = (a_{ij})$, the restatement given by Equation (7.15) reduces our problem to a power allocation problem without macrodiversity as it is addressed in [15]. Our $M \times N$ macrodiversity network is equivalent to a $MN \times N$ fixed cell network: each user X_i is subdivided into N independent users $(X_i^j)_{1 \leq j \leq N}$, X_i^j is affiliated to base station j and has SINR requirement of $a_{ij} h_i$. We define the linear mapping:

$$\mathcal{T} : \begin{cases} \mathcal{A} & \rightarrow \mathbb{R}^{N \times N} \\ A & \mapsto T = (\sum_i a_{ij} h_i \frac{L_{ik}}{L_{ij}})_{1 \leq j, k \leq N} \end{cases}.$$

Let $\rho(T)$ denote the spectral radius of the square matrix T . We then have the following necessary and sufficient condition:

Proposition 7.3.2 Let,

$$\rho_{\downarrow} = \min_{A \in \mathcal{A}} \rho(\mathcal{T}(A)). \quad (7.16)$$

Equation (7.15) has a solution if and only if $\rho_{\downarrow} < 1$.

ρ_{\downarrow} is the *downlink load* of the network. Since $\rho(T + \tilde{T}) \leq \rho(T) + \rho(\tilde{T})$, ρ_{\downarrow} is computed as an optimization of a convex function over a convex set.

Proof. Note that $\rho_{\downarrow} = \rho(\mathcal{T}(A^*))$, $A^* \in \mathcal{A}$. This proposition is a consequence of Propositions 3.1 to 3.3 of [15] in the finite dimensional case. For the reader convenience, we sketch the main idea. Consider the allocation matrix A^* . The base station j guarantees an individual signal to noise ratio of at least $h_i a_{ij}^*$ to user i . We define S_j has the total power emitted by station j : $S_j = \sum_i S_{ij}$. Let $S = (S_j)_j$ be the vector of total emitted powers, by elementary calculations that Equation (7.15) implies component-wise: $S \geq \mathcal{T}(A^*)S + b$, where b contains the noise of the channel. This inequality is solved by the Perron-Frobenius theory, and the existence of a non-negative vector S relies on whether or not the spectral radius of $\mathcal{T}(A^*)$ is less than one. It remains to prove that if the inequality for the total emitted powers S has a solution, then it is possible to compute the individual powers S_{ij} . \square

On the uplink, the feasibility of the power control problem did not depend on the geometry of the network. On the downlink, on the contrary, in the computation of ρ_{\downarrow} , the locations of the users is relevant.

Lemma 7.3.3 If $A \in \mathcal{A}^*$:

$$\frac{1}{N} \sum_{i=1}^M h_i \leq \rho(\mathcal{T}(A)) \leq \sum_{i=1}^M h_i. \quad (7.17)$$

The right hand side bound of (7.17) is simply obtained by removing all base stations but one in the network. This bound cannot be improved without taking into account the locations of the users (see Remark 7.3.4). We can compare the left hand side with Theorem 7.2.1. On the uplink, there is a solution to the power allocation if and only if $1/N \sum_{i=1}^M h_i < 1$. On the downlink this condition is only necessary.

Proof. For any matrix T , $\text{trace}(T) = \sum_{i=1}^M h_i = \sum_j \lambda_j$, where $(\lambda_j)_j$ are the eigenvalues of T . Since $\rho(T)$ is the largest eigenvalue, we deduce the left hand side.

It remains the right hand side of Equation (7.17). Consider the allocation matrix $A \in \mathcal{A}$ where the j^{th} column is 1 and all the others are set to 0. We immediately check: $\rho(\mathcal{T}(A)) = \sum_i h_i$. \square

Remark 7.3.4 There exists configurations such that the two bounds of Equation (7.17) are reached.

A limit configuration reaching left hand side of Equation (7.17). Consider a network on a line and suppose to simplify: $M = KN$, K integer. Then place the base stations Y_j at locations jr and place K users (X_1^j, \dots, X_K^j) at jr . Consider now the allocation $A = (a_{ij})$, a_{ij} taking value 1 if X_i is an X_m^j and 0 otherwise. We can check directly that if $L(x, y)$ goes to 0 as the distance between x and y goes to infinity, $\rho(\mathcal{T}(A))$ tends to $\frac{1}{N} \sum_{i=1}^M h_i$ as r tends toward infinity.

A configuration reaching right hand side of Equation (7.17). Consider, the case where all M users are at the same location. We define $l_j = L(X_i, Y_j) > 0$ and let D be the diagonal matrix whose diagonal is (l_1, \dots, l_N) . In this case, we have $T = D^{-1}MD$, with $M_{jk} = \sum_i a_{ij} h_i$. T and M have the same spectral radius. Then notice that $M = U\mathbf{1}^t$, where U and $\mathbf{1}$ are \mathbb{R}^N positive vectors and it follows that $\rho(T) = \rho(M) = \mathbf{1}^t U = \sum_i h_i$.

7.3.3 Optimal Power Allocation

In this paragraph, we state an interesting property shared by the optimal allocation matrices $A \in \mathcal{A}^* = \{A \in \mathcal{A} : \rho(\mathcal{T}(A)) = \rho_{\downarrow}\}$.

For the sake of simplicity, we will suppose that for all $x, y \in \mathbb{R}^2$, $L(x, y) > 0$. We can also suppose that if $T = \mathcal{T}(A)$ where $A \in \mathcal{A}^*$:

$$\forall j, k, \quad T_{jk} > 0. \quad (7.18)$$

Indeed, if $T_{jk} = 0$ for some k , then the j^{th} row is equal to 0. Thus, T and the sub-matrix of T obtained by removing the j^{th} row and the j^{th} column have the same spectral radius.

For $A \in \mathcal{A}$, we define two sets:

$$I(A) = \{i \in \{1, \dots, M\}, \exists a_{i,j} \in (0, 1) \text{ for some } j\},$$

$$J(A) = \{(i, j), a_{i,j} \in (0, 1)\}.$$

$I(A)$ is understood as the set of users for which two or more base stations are actively contributing to satisfy its SINR requirement. For a discrete set K , $|K|$ denotes the cardinal of K . We have the following theorem:

Theorem 7.3.5 We assume that for all integer n , for all sequences i_1, \dots, i_n of $\{1, \dots, M\}$ and for all sequences of distinct integers j_1, \dots, j_n of $\{1, \dots, N\}$, we have (with $j_{n+1} = j_1$):

$$\prod_{k=1}^n \frac{l_{i_k, j_k}}{l_{i_k, j_{k+1}}} \neq 1. \quad (7.19)$$

Then if $A \in \mathcal{A}^*$:

$$|J(A)| - |I(A)| < N. \quad (7.20)$$

Corollary 7.3.6 If $A \in \mathcal{A}^*$, $|I(A)| < N$.

This theorem gives an upper bound to the number of users which are really in macrodiversity, i.e. to the number of users which are receiving a signal from more than two different base stations. Provided that the assumption is satisfied, this upper bound does not depend on the geometry. This bound is also surprisingly small: on a typical wireless network, $M \gg N$, so the proportion of users in macrodiversity is small.

We denote $\tilde{\mathcal{A}} = \{A \in \mathcal{A} : \forall i, j, a_{ij} \in \{0, 1\}\}$, the set of allocation matrices such that each user is affiliated to a unique base stations, the *load-balanced downlink load* is defined as:

$$\tilde{\rho}_\downarrow = \min_{A \in \tilde{\mathcal{A}}} \rho(\mathcal{T}(A)).$$

$\tilde{\rho}_\downarrow$ is the load corresponding to a network where each user is affiliated to a unique base station.

In view of Theorem 7.3.5, we may guess that $\tilde{\rho}_\downarrow / \rho_\downarrow$ is close to 1. In fact, in the special case, $N = 2$ (two base stations) we can actually show that the two minima are equal. In the §7.3.5, we will state that this intuition makes sense when M grows large.

Assumption (7.19) is not very restrictive in our context. In a probabilistic setting, it would be easily almost surely satisfied.

The proof of Theorem 7.3.5 is postponed to the next paragraph. It does not contain any intuition on the result. Note however that even if Theorem 7.3.5 may be surprising in view of its application, it is quite natural if ρ_\downarrow is seen as the minimum of a convex function, $T \mapsto \rho(T)$, on a compact convex set, \mathcal{A} . With reasonable assumptions, this minimum is reached on the boundary of the set \mathcal{A} , that is the subset of $\tilde{\mathcal{A}}$

7.3.4 Proof of Theorem 7.3.5

In the following, $\|\cdot\|$ is any given norm on $\mathbb{R}^{N \times N}$ and $\langle \cdot, \cdot \rangle$ is the usual scalar product on \mathbb{R}^N . I is the identity matrix in $\mathbb{R}^{N \times N}$. Two lemmas are necessary before turning to the proof. The first lemma is simply an expansion of order 1 of $T \mapsto \det(xI - T)$ in the neighborhood of T .

Lemma 7.3.7 Let $\Phi_T(x)$ be the characteristic polynomial of T and $Adj(T)$ its adjoint; for all $H \in \mathbb{R}^{N \times N}$ we have:

$$\Phi_{T+H}(x) = \Phi_T(x) + \sum_{j,k} H_{jk} Adj(xI - T)_{jk} + o(\|H\|). \quad (7.21)$$

For $T \in \mathcal{T}(\mathcal{A})$, we define: $\mathcal{H}_T = \{H \in \mathbb{R}^{N \times N} : T + H \in \mathcal{T}(\mathcal{A})\}$.

Lemma 7.3.8 If $T \in \mathcal{T}(\mathcal{A}^*)$ then on a neighborhood \mathcal{V}_0 of the null matrix:

$$\forall H \in \mathcal{H}_T \cap \mathcal{V}_0, \quad \langle H v_T, w_T \rangle \leq 0, \quad (7.22)$$

where, v_T and w_T are respectively the left and right eigenvectors of T associated to eigenvalue $\rho(T)$.

Proof. From Equation (7.18), T is primitive, hence (from Seneta [142]): $\text{Adj}(\rho(T)I - T) = \Phi'_T(\rho(T))w_T v'_T$ and $\Phi'_T(\rho(T)) > 0$. For $x = \rho(T)$, Equation (7.21) reduces to:

$$\Phi_{T+H}(\rho(T)) = \Phi'_T(\rho(T))\langle H v_T, w_T \rangle + o(\|H\|). \quad (7.23)$$

If $T \in \mathcal{T}(\mathcal{A}^*)$, then $\rho(T + H) \geq \rho(T)$ for all $H \in \mathcal{H}^T$. This implies $\Phi_{T+H}(\rho(T)) \leq 0$ for H sufficiently small. (7.22) follows from (7.23) and $\Phi'_T(\rho(T)) > 0$. \square

We can now prove Theorem 7.3.5.

Proof of Theorem 7.3.5.

Let $A = (a_{ij}) \in \mathcal{A}^*$ and $T = \mathcal{T}(A)$. w and v are the right and left eigenvectors of T associated to $\rho(T)$. For each $i_0 \in I$, we can find $j_1 \neq j_2$ such that $a_{i_0, j_1} > 0$ and $a_{i_0, j_2} > 0$, we define the matrix A^ϵ by:

$$(A^\epsilon)_{ij} = A_{ij} + \epsilon \delta_{i, i_0} \delta_{j, j_1} - \epsilon \delta_{i, i_0} \delta_{j, j_2} \quad (\delta \text{ is the Kronecker symbol}).$$

For $\epsilon > 0$ small enough A^ϵ and $A^{-\epsilon}$ are in \mathcal{A} , hence $H = \mathcal{T}(A^\epsilon) - T$ and $-H = \mathcal{T}(A^{-\epsilon}) - T$ are both in \mathcal{H}_T . We can apply Lemma 7.3.8 and it follows:

$$\begin{aligned} 0 &= \langle H v, w \rangle \\ &= \left(\sum_k l_{i_0 k} v_k \right) \left(\frac{w_{j_1}}{l_{i_0 j_1}} - \frac{w_{j_2}}{l_{i_0 j_2}} \right) \end{aligned}$$

The last equality implies, since $l_{i_0 k} > 0$ and $v_k > 0$:

$$\frac{w_{j_1}}{l_{i_0 j_1}} = \frac{w_{j_2}}{l_{i_0 j_2}} \quad (7.24)$$

The end of the proof relies on a simple argument on graphs. Let $I = I(A)$ and $J = J(A)$, without loss of generality, we can suppose $I = \{1, \dots, |I|\}$. Let $J_i = \{j, (i, j) \in J\}$.

We now define the embedded non-oriented graphs \mathcal{G}_i on the set $\{1, \dots, N\}$ of base stations. We put an edge in \mathcal{G}_i between j_1, j_2 if there exists an integer $i_0 \leq i$ such that j_1 and j_2 are in J_{i_0} . From what precedes, this implies (7.24).

Similarly we define the graph \mathcal{J}_i by putting an edge between j_1 and j_2 if j_1 and j_2 are in J_i . By construction, we have $\cup_{i=1}^l \mathcal{J}_i = \mathcal{G}_l$.

We now remark that Assumption (7.19) together with Equation (7.24) implies that if there is a path leading from j_1 to j_2 in \mathcal{G}_i , there cannot be any edge between j_1 and j_2 in \mathcal{J}_{i+1} . In other words, a set of connected nodes in \mathcal{G}_i and a set of connected nodes in \mathcal{J}_{i+1} cannot have more than one common node.

Let N_i be the number of non-isolated nodes in \mathcal{G}_i and $n_c(i)$ be the number of connected components in \mathcal{G}_i not reduced to an isolated node. We obtain:

$$N_1 = |J_1|.$$

The constraint on our embedded graphs implies that adding the edges of \mathcal{J}_{i+1} to \mathcal{G}_i can either merge two distinct connected components of \mathcal{G}_i , increase a connected component or add a new connected component. In these three possible cases, the following formula is satisfied:

$$N_{i+1} = N_i + |J_{i+1}| + n_c(i+1) - n_c(i) - 1,$$

at last, by summing this last equation from 1 to $|I| - 1$, we obtain

$$|J| - |I| \leq N - n_c(|I|),$$

which in turn implies Equation (7.20). Since $|J_i| \geq 2$, $|J| \geq 2|I|$ and the corollary follows. \square

7.3.5 Asymptotic Load

Even for the simplest probabilistic models, the computation of ρ_{\downarrow} is by far less easy than the computation of ρ_{\uparrow} . In this paragraph, we show however that it is possible to compute the scaling limit of ρ_{\downarrow} when the number of users tends to infinity.

The N base stations are fixed and deployed in a bounded region $\Omega \subset \mathbb{R}^2$. We consider an ergodic sequence of users $\{X_i, h_i\}_{i \in \mathbb{Z}}$ with h_i independent of X_i , $0 < E(h_0) < \infty$, $X_i \in \Omega$ and for all measurable subset $A \subset \Omega$, $P(X_i \in A) = \int_A \lambda(x) dx$. $\lambda(x)$ is the spatial intensity (or density here) of users in Ω . As last the attenuation $L(x, y)$ is positive.

We pay attention to the load in the network when the set of users is $\{X_i, h_i^{(M)}\}_{1 \leq i \leq M}$ where $h_i^{(M)} = h_i/M$ is the scaled SINR of user i . In this paragraph, we need to explicit the dependency of the problem in M so that we define $\mathcal{A}_M = \{A = (a_{ij}) \in \mathbb{R}_+^{N \times N} : \text{for } i > M \ a_{ij} = 0, \text{ for } 1 \leq i \leq M \ \sum_j a_{ij} = 1\}$, \mathcal{A}_{∞} is simply denoted by \mathcal{A} and we introduce the linear mapping:

$$\mathcal{T}_M : \begin{cases} \mathcal{A} & \rightarrow \mathbb{R}^{N \times N} \\ A & \mapsto T = (\sum_i a_{ij} h_i^{(M)} \frac{L_{ik}}{L_{ij}})_{1 \leq j, k \leq N} \end{cases},$$

\mathcal{T}_1 is simply denoted by \mathcal{T} (this is consistent with its definition in §7.3.2). The downlink load associated to the set of users $\{X_i, h_i^{(M)}\}_{1 \leq i \leq M}$ is by definition:

$$\rho_{\downarrow}^{(M)} = \min_{A \in \mathcal{A}_M} \rho(\mathcal{T}_M(A)) = \frac{1}{M} \min_{A \in \mathcal{A}_M} \rho(\mathcal{T}(A)).$$

For load balanced allocations, we define similarly, \tilde{A}_M and $\tilde{\rho}_{\downarrow}^{(M)}$.

Lemma 7.3.9 There exists $0 < \rho_{\downarrow}^{\infty} \leq \tilde{\rho}_{\downarrow}^{\infty}$ such that almost surely:

$$\lim_{M \rightarrow \infty} \rho_{\downarrow}^{(M)} = \rho_{\downarrow}^{\infty} \quad \text{and} \quad \lim_{M \rightarrow \infty} \tilde{\rho}_{\downarrow}^{(M)} = \tilde{\rho}_{\downarrow}^{\infty}. \quad (7.25)$$

Proof. For $p < q \in \mathbb{N}$, we define $\mathcal{A}_{p,q} = \{A = (a_{ij}) \in \mathbb{R}_+^{N \times N} : \text{for } i \notin \{p, \dots, q\} \ a_{ij} = 0, \text{ for } i \in \{p, \dots, q\} \ \sum_j a_{ij} = 1\}$, the set of allocations matrices for users indexed from p to q . Note that if $A_{1,p} \in \mathcal{A}_{1,q}$, we have $\mathcal{T}(A_{1,q}) = \mathcal{T}(A_{1,p}) + \mathcal{T}(A_{p+1,q})$, where the matrices $A_{1,p} \in \mathcal{A}_{1,p}$ and $A_{p+1,q} \in \mathcal{A}_{p+1,q}$ are obtained from $A_{1,q}$ by setting to 0 all rows not in $\{1, p\}$ and $\{p+1, q\}$ respectively. Since, $\rho(T + \tilde{T}) \leq \rho(T) + \rho(\tilde{T})$ we deduce:

$$\min_{A \in \mathcal{A}_{1,q}} \rho(\mathcal{T}(A)) \leq \min_{A \in \mathcal{A}_{1,p}} \rho(\mathcal{T}(A)) + \min_{A \in \mathcal{A}_{p+1,q}} \rho(\mathcal{T}(A)).$$

The existence of $\rho_{\downarrow}^{\infty}$ and $\tilde{\rho}_{\downarrow}^{\infty}$ follows then directly from Kingman's subadditive ergodic theorem. The positivity of $\rho_{\downarrow}^{\infty}$ is a consequence of Lemma 7.3.3. \square

Before stating the main result of this paragraph, we need a couple of definitions.

A set of measurable functions, $f_j : \mathbb{R}^2 \rightarrow \mathbb{R}$, $1 \leq j \leq N$ is said to be *singular* if there exists a measurable set A of positive Lebesgue measure and a constant C such that $f_j(x) = C f_k(x)$ for some $j \neq k$. By extension, the base stations locations is said to be singular if the set of attenuation functions $x \mapsto L(x, Y_j)$ is singular. This notion of singularity is purely technical and it is not a strong assumption in view of applications.

A tessellation is a collection of measurable sets partitioning the region Ω , we denote by $\mathcal{V} = \{V = (V_j)_{1 \leq j \leq N} : \text{almost everywhere } \sum_j \mathbf{1}_{V_j}(x) = 1\}$ the set of tessellation composed of N sets. We identify two tessellations V and V' in \mathcal{V} if for all j , $\mathbf{1}_{V_j}$ and $\mathbf{1}_{V'_j}$ are almost everywhere (a.e.) equal.

Theorem 7.3.10 If the base stations locations are non singular then

$$\rho_{\downarrow}^{\infty} = \tilde{\rho}_{\downarrow}^{\infty} = E(h_0)\gamma,$$

where

$$\gamma = \min_{V \in \mathcal{V}} \rho(\mathcal{T}'(V))$$

and $\mathcal{T}'(V)_{j,k} = \int_{V_j} \frac{L(x, Y_k)}{L(x, Y_j)} \lambda(x) dx$.

This theorem sheds a new light on the downlink load when the number of users is large. First, it strengthens the intuition that macrodiversity and load balancing lead to the same level of load in the network. Secondly, we have been able to compute explicitly the limit behavior of the asymptotic behavior of the network. As an example, a practical consequence is the following approximation for a set of M users located at (X_i) with SINR requirement (h_i) , from Equation (7.25) we get:

$$\rho_{\downarrow} \sim \gamma \sum_{j=1}^M h_i,$$

We have completely decoupled the SINR requirement and the geometry of the network which is contained in the scalar γ .

There is a third consequence of Theorem 7.3.10. Define $V^* = (V_j^*)_j$ as the optimal tessellation (defined up to null measure sets) such that:

$$\rho(\mathcal{T}'(V^*)) = \gamma.$$

We consider a traditional cellular network architecture with associated cells V_j^* with M users (X_i) distributed according to $\lambda(x)dx$ with SINR requirement $(h_i^{(M)})$. The user i is attached to base station j if $X_i \in V_j^*$: that is the associated allocation matrix A_M^* satisfies: for $i \leq M$, $a_{ij}^* = \mathbf{1}(X_i \in V_j)$. The *cellular downlink load* is equal to $\bar{\rho}_{\downarrow}^{(M)} = \rho(\mathcal{T}_M(A_M^*))$. As the number of users M grows large, from the law of large number, $\bar{\rho}_{\downarrow}^{(M)}$ tends to $E(h_0)\gamma$. Therefore an optimal cellular architecture has asymptotically the same load than a network in macrodiversity.

The proof of Theorem 7.3.10 is postponed to the next paragraph.

Example 7.3.11 Hexagonal Grid. $\Omega = [0, 1]^2$ is seen as a torus to avoid boundary effects, and the users are uniformly distributed on Ω . We suppose that the set of base stations is located on a regular hexagonal grid of radius $R = 1/L$, with L integer. We index our base station with two indices in $\{0, \dots, L-1\}$ and with a complex representation of \mathbb{R}^2 , the base station (p, q) is located at $Y_{p,q} = R(p + qe^{i\frac{\pi}{3}})$. Let $\{V_j\}$ be the Voronoi Tessellation of the hexagonal network (that is, $x \in V_j$ if for all $j' \neq j$, $|x - Y_j| < |x - Y_{j'}|$). If $L(x, y) = l(|x - y|)$, then the symmetry of the network leads to

$$\gamma = \int_{V_{0,0}} \frac{I(x)}{l(|x|)} dx,$$

where $I(x) = \sum_j l(|x - Y_j|)$. This last equation has an intuitive meaning: in a symmetric network, the optimal cellular architecture is obtained by equalizing the individual load of each base station.

7.3.6 Proof of Theorem 7.3.10

Let $V = (V_j)_j$ a tessellation in \mathcal{V} and $A^{(M)} \in \mathcal{A}_M$ the allocation matrix corresponding to the cellular network with cells $(V_j)_j$: for $i \leq M$, $a_{ij}^{(M)} = \mathbf{1}(X_i \in V_j)$. By ergodicity, for all j, k a.s. we have:

$$\lim_{M \rightarrow \infty} \mathcal{T}(A^{(M)})_{jk} = E(h_0) \int_{V_j} \frac{L(x, Y_k)}{L(x, Y_j)} \lambda(x) dx.$$

The spectral radius is a continuous function of the entries of the matrix. Hence, taking the infimum over \mathcal{V} , we thus deduce:

$$\rho_{\downarrow}^{\infty} \leq \tilde{\rho}_{\downarrow}^{\infty} \leq E(h_0)\gamma.$$

It remains to prove that $E(h_0)\gamma \leq \rho_{\downarrow}^{\infty}$. To this end, we define the following set of measurable functions:

$$\mathcal{F} = \{f = (f_j)_{1 \leq j \leq N} : f_j : \Omega \rightarrow \mathbb{R}_+, \text{ a.e. } \sum_j f_j(x) = 1\}.$$

\mathcal{F} is the convex hull of the set of tessellations.

Let $A^{(M)} = (a_{ij}^{(M)})$ be a sequence of allocation matrices such that $\rho_{\downarrow}^{(M)} = \rho(\mathcal{T}(A^{(M)}))/M$. We define the empirical allocation measure $\mu_j^{(M)}$ as,

$$\mu_j^{(M)} = \frac{1}{M} \sum_{i=1}^M a_{ij}^{(M)} \delta_{X_i}.$$

For each j , the sequence $\{\mu_j^{(M)}\}_M$ is tight, so that we may extract a converging subsequence to a limit measure μ_j (for the weak convergence of measures). Notice that:

$$\sum_{j=1}^N \mu_j^{(M)} = \frac{1}{M} \sum_{i=1}^M \delta_{X_i},$$

letting M tends to infinity, we get:

$$\sum_{j=1}^N \mu_j = \ell_{\lambda},$$

with $\ell_{\lambda}(A) = \int_A \lambda(x) dx$. In particular μ_j is absolutely continuous with respect to ℓ_{λ} . Let f_j^* be the Radon-Nikodym derivative of μ_j with respect to ℓ_{λ} . $\int_{\Omega} \lambda(x) dx = 1$ implies that $f^* = (f_j^*) \in \mathcal{F}$. If $h(x) = \sum_i \mathbf{1}(x = X_i) h_i$, the entry (j, k) of the matrix $\mathcal{T}(A^{(M)})/M$ is equal to:

$$\int h(x) \frac{L(x, Y_k)}{L(x, Y_j)} \mu_j^{(M)}(dx)$$

The spectral radius is a continuous function of the entries of the matrix (remember that the size of $\mathcal{T}(A^{(M)})$ is fixed to $N \times N$, so no continuity problem may occur). We obtain:

$$\rho_{\downarrow}^{\infty} = E(h_0) \rho(\mathcal{T}'(f^*)).$$

where

$$\mathcal{T}'(f)_{j,k} = \int \frac{L(x, Y_k)}{L(x, Y_j)} f_j(x) \lambda(x) dx.$$

(Assume first that h_i takes a finite number of distinct values and then extend to the general case).

It remains to prove that $\rho(\mathcal{T}'(f^*)) = \gamma$. First note that by definition of $\rho_{\downarrow}^{\infty}$:

$$\rho(\mathcal{T}'(f^*)) = \min_{f \in \mathcal{F}} \rho(\mathcal{T}'(f)). \quad (7.26)$$

So that $\rho(\mathcal{T}'(f^*))$ is the minimum of a convex function over a compact convex set. The last step is the following Lemma:

Lemma 7.3.12 If the base stations locations are not singular then

$$\gamma = \min_{V \in \mathcal{V}} \rho(\mathcal{T}'(V)) = \min_{f \in \mathcal{F}} \rho(\mathcal{T}'(f))$$

This lemma is a continuous analog of Theorem 7.3.5.

Proof. We consider the $f^* \in \mathcal{F}$ given by Equation (7.26). Let $E = f_1^*(]0, 1[)^{-1} \cap f_2^*(]0, 1[)^{-1}$. In this proof, ℓ will denote the Lebesgue measure. We need to show that $\ell(E) = 0$. Suppose instead that $\ell(E) > 0$, we can suppose without loss of generality that $\ell(E) < +\infty$. For ϵ_0 small enough, there exists $E' \subset E$ with $\ell(E') > 0$ such that for all $x \in E'$, $\min(f_1(x), f_2(x)) > \epsilon$ and $\max(f_1(x), f_2(x)) < 1 - \epsilon$. Let $A \subset E'$ and let $f_1^{\epsilon}(x) = f_1(x) + \epsilon \mathbf{1}_A(x)$, $f_2^{\epsilon}(x) = f_2(x) - \epsilon \mathbf{1}_A(x)$ and $f_j^{\epsilon}(x) = f_j(x)$ for $j \notin \{1, 2\}$. If $0 < \epsilon < \epsilon_0$, f^{ϵ} and $f^{-\epsilon}$ are in \mathcal{F} .

Let $T = \rho(\mathcal{T}'(V^*))$ and w and v are the right and left eigenvectors of $\rho(T) = \gamma$. We can apply Lemma 7.3.8 to $H = \mathcal{T}'(f^{\epsilon})$ and $-H = \mathcal{T}'(f^{-\epsilon})$, we deduce that:

$$\begin{aligned} 0 &= \langle Hv, w \rangle \\ &= \epsilon \int_A \left(\sum_k L(x, Y_k) v_k \right) \left(\frac{w_1}{L(x, Y_1)} - \frac{w_2}{L(x, Y_2)} \right) \lambda(x) dx. \end{aligned}$$

The last equality implies,

$$w_1 \int_A \frac{1}{L(x, Y_1)} dx = w_2 \int_A \frac{1}{L(x, Y_2)} dx. \quad (7.27)$$

Thus, for all A included E' , such that $\ell(A) > 0$:

$$\frac{1}{\ell(A)} \int_A \frac{1}{L(x, Y_1)} dx - \frac{w_1}{w_2} \frac{1}{\ell(A)} \int_A \frac{1}{L(x, Y_1)} dx = 0.$$

We can apply Theorem 1.40 of [141] and conclude that a.e. in E' :

$$L(x, Y_1) = \frac{w_1}{w_2} L(x, Y_2).$$

This contradicts our hypothesis the non singularity assumption. Therefore $\ell(E) = 0$. We have also proved that the minimum is uniquely reached (up to null measure sets). \square

7.3.7 Infinite Networks

In the previous paragraph, we have computed the downlink load as the number of users grows large and the number of base stations is fixed. As on the uplink, it is an appealing idea to compute ρ_{\downarrow} for infinite networks, that is when both the numbers of users and base stations are infinite. The power control problem is still given by the set of inequalities (7.14) and Lemma 7.3.1 remains obviously true. Thus, we can still follow the line of [15]. We can still define \mathcal{A} and the linear mapping \mathcal{T} . Proposition 7.3.2 has an infinite dimensional analogue.

First, we recall some results on infinite recurrent matrices. Let us denote by $T^n = (T_{jk}^n)$, the n^{th} power of T . The power series $T_{jk}(z) = \sum_n T_{jk}^n z^n$ have a common convergence radius $R(T) = \frac{1}{\rho(T)}$; $\rho(T)$ is by definition the spectral radius of T . $T_{jj}(R)$ is finite or infinite at the same time for all j , making T respectively *transient* or *recurrent*. For more refer to Seneta [142]. As a consequence of Propositions 3.1 to 3.3 of [15].

Proposition 7.3.13 Let,

$$\rho_{\downarrow} = \min_{A \in \mathcal{A}} \rho(\mathcal{T}(A)),$$

- if $\rho_{\downarrow} < 1$ then Equation (7.14) has a solution ,
- if $\rho_{\downarrow} > 1$ then Equation (7.14) does not admit any solution,
- if $\rho_{\downarrow} = 1$ and $\rho_{\downarrow} = \rho(\mathcal{T}(A^*))$, Equation (7.14) has a solution if $\mathcal{T}(A^*)$ is transient.

We model base stations and users by considering two point processes on \mathbb{R}^2 : $\Pi_s = \{Y_j\}_j$ and $\Pi_u = \{(X_i, h_i, \eta_i)\}_i$, h_i and η_i are the marks of the point process. The marks are supposed identically distributed, independent and independent of the rest of the model. We suppose that the point process of users Π_u is a stationary Poisson process of intensity $\lambda_u > 0$. At last, we consider a radial attenuation function, that is: $L(x, y) = l(|x - y|)$. As usual, we can suppose $l(r) > 0$ for all $r \in \mathbb{R}^+$.

We have the following negative result:

Theorem 7.3.14 For $t \in \mathbb{R}$, let $l_t : r \mapsto l(\max(r - t, 0))$, we denote by $\|\cdot\|_{\infty}$ the uniform norm. If:

$$\lim_{t \rightarrow 0} \left\| \frac{l_t}{l} \right\|_{\infty} = 1, \quad (7.28)$$

then:

$$\rho_{\downarrow} = +\infty, \quad \text{almost surely.}$$

Assumption (7.28) is used to get a continuity of the entries of $\mathcal{T}(A)$ with respect to the users' locations $\{X_i\}_{i \in \mathbb{N}}$. However, the theorem should be true for a larger class of attenuation functions.

This result asserts that whatever the intensity of base stations is, there is no solution of the power allocation problem. It implies that some admission congestion protocol must be enforced in a CDMA network on the downlink. Otherwise, as the proof of Theorem 7.3.14 shows, there will always be a local concentration of users which saturates the whole network. If we compare to Theorem 7.2.3, this result is in complete opposition with what happens on the uplink. Theorem 7.3.14 is somewhat disappointing, the stationary point process for users' location framework does not lead to a right concept of spatial load.

The proof of Theorem 7.3.14 relies on classical results on spectral radius (see [142] for details).

Lemma 7.3.15 Let T and S be non-negative matrices (possibly infinite), then:

- if $\forall j, k \ T_{jk} \geq S_{jk}$, then $\rho(T) \geq \rho(S)$,
- for all square sub-matrix \tilde{T} of T , $\rho(T) \geq \rho(\tilde{T})$.

Proof of Theorem 7.3.14. Without loss of generality we can suppose that $h_i > 0$, indeed $\sum_i \mathbf{1}(h_i > 0) \delta_{X_i, h_i, \eta_i}$ is still a poisson point process with independent marks. Let R, h be some positive real numbers and M an integer. The event $A_i = \{\Pi_u(B(X_i, R)) \geq M\} \cap \{\forall X_k \in B(X_i, R), \ h_k > h\}$ has a positive probability, provided h small enough. Hence using the independency property of Poisson processes, $\sum_i \mathbf{1}_{A_i} = \infty$ almost surely. We consider one of these configurations.

Without loss of generality, we can also suppose $i = 1$ and $X_1 = 0$: $\forall k \in \{1 \dots M\}$, $X_k \in B(0, R)$ and $h_k > h$.

Fix $1 > \epsilon > 0$ from Hypothesis (7.28), for ϵ small enough, there exists R such that:

$$\forall x \in B(0, R), \forall y \in \mathbb{R}^2, \quad |l(|x - y|) - l(|y|)| \leq l(|y|)\epsilon.$$

Hence, for all $X_i \in B(0, R)$ we easily check:

$$\left| \frac{L(0, Y_k)}{L(0, Y_j)} - \frac{L(X_i, Y_k)}{L(X_i, Y_j)} \right| \leq \frac{\epsilon}{1 - \epsilon} \frac{L(0, Y_k)}{L(0, Y_j)}. \quad (7.29)$$

Let $T = \mathcal{T}(A)$, we have

$$T_{jk} \geq \tilde{T}_{jk} = h \sum_{i=1}^M a_{ij} \frac{L(X_i, Y_k)}{L(X_i, Y_j)},$$

and, by lemma 7.3.15, $\rho(T) \geq \rho(\tilde{T})$.

Now, if $\tilde{T}^{(N)}$ denotes the sub-matrix of \tilde{T} extracted from the first N rows and N columns, from (7.29), we deduce:

$$\tilde{T}_{jk}^{(N)} \geq h \left(1 - \frac{\epsilon}{1 - \epsilon}\right) \frac{L(0, Y_k)}{L(0, Y_j)} \sum_{i=1}^M a_{ij}. \quad (7.30)$$

Moreover, there exists N such that $\sum_{j=1}^N \sum_{i=1}^M a_{ij} \geq M(1 - \epsilon)$. For such N , define, the $N \times N$ matrix, $\hat{T}^{(N)}$, with $\hat{T}_{jk}^{(N)}$ is equal to the right hand side of (7.30). From lemma 7.3.15, $\rho(\tilde{T}) \geq \rho(\tilde{T}^{(N)}) \geq \rho(\hat{T}^{(N)})$. Computing the spectral radius of $\hat{T}^{(N)}$, we obtain:

$$\rho(T) \geq \rho(\hat{T}^{(N)}) \geq hM(1 - 2\epsilon).$$

We thus have proved that $\rho(T)$ cannot be upper bounded.

7.4 Dynamic Model on the Downlink

7.4.1 User Arrival Process

We now describe a model of data flows on a CDMA network in macrodiversity. A time component is added to the model: the users arrive and leave the system. As above we suppose we have a set of base stations deployed on the plane. The users arrive in the network with a service requirement and they leave when it has been fulfilled. A given user, say n , arrives in the network, at time T_n , located in point X_n of the plane and it requires to receive an amount σ_n of bits. Our user n can receive its data from any base station in the network. The set of our user is a simple marked point process A , we denote by $A([0, t] \times B)$ the number of users arriving in the set $B \subset \mathbb{R}^2$ between times 0 and t . We suppose that:

$$E(A([0, t] \times B)) = t \int_B \lambda(dx), \quad (7.31)$$

where $\lambda(dx)$ is a measure finite on all bounded set (i.e. a *Radon measure*) and E is the expectation. $\lambda(dx)$ is the *spatial intensity* of our space-time point process A .

In particular, Equation (7.31) implies that A is time-stationary. We make however a stronger probabilistic assumption on A , namely we suppose that A is *time-ergodic*, in particular (from Birkhoff's Theorem) it implies that almost surely (a.s.):

$$\lim_{t \rightarrow +\infty} \frac{1}{t} \sum_n 1(T_n \in [0, t], X_n \in B) \sigma_n = \int_B E_A^{0,x}(\sigma_{0,x}) \lambda(dx),$$

where $P_A^{0,x}(\cdot)$ is the Palm measure of A at $(0, x)$. $E_A^{0,x}(\sigma_{0,x})$ is the mean number of bits required by a user arriving at x under the Palm distribution. We assume that the bits requirements of users satisfy: $E_A^{0,x}(\sigma_{0,x}) < +\infty$.

For example, if the spatial intensity is λdx , then the arrival of users is also *space-stationary*. For example A could be a space-time homogeneous Poisson point process. In applications, there can also be some hot-spots where the density of users is high, a spatial intensity measure of type $\lambda(x)dx$ would describe this kind of users' patterns. We could also consider a scenario where there are some fixed entry points to other networks: in this case, $\lambda(dx)$ would have a Dirac mass at entry points.

Let T'_n be the time of departure of the user n of our arrival point process A and for t in the interval $[T_n, T'_n)$, $\sigma_n(t)$ denotes the remaining number of bits at time t the user n wants to receive: $\sigma(T_n) = \sigma_n$ and $\sigma(T'_n) = 0$.

At time t the workload in the network is a measure on \mathbb{R}^2 with atoms at users locations. More formally, the workload at time t , W_t , is defined as:

$$W_t = \sum_n \sigma_n(t) \mathbf{1}(t \in [T_n, T'_n)) \delta_{X_n}, \quad (7.32)$$

where δ_x is a unit mass at x . For a set B , $W_t(B)$ is the total number of bits required by users in B at time t .

7.4.2 Base Station Adaptive Policy

We now describe how the base stations are serving the users. In a macrodiversity network, the base stations can serve any user, wherever it is. Let $r_n(t)$ be the bit rate achieved for user n in the system at time t . As above Δ is the bandwidth of the channel, with the notation of §7.3.1, let $h_n(t) = 1 - 2^{-\frac{r_n(t)}{\Delta}}$ be the bit rate that user n receives from the network at time t and $A(t) = (a_{nj}(t)) \in V$ the allocation matrix at time t . Let $h_{nj}(t) = a_{nj}(t)h_n(t)$ be the instantaneous bit rate given by station j to user n : $\sum_j h_{nj}(t) = 1 - 2^{-\frac{r_n(t)}{\Delta}}$. For consistency, we require that $h_{nj}(t)$ can be positive only when t lies in $[T_n, T'_n]$.

In CDMA networks, the signal bandwidth is large (Δ is around 1.5 MHz). In view of Equation (7.3.1), for large bandwidth the capacity of the channel becomes linear with the power of the signal. The following approximation is thus justified:

$$\begin{aligned} \frac{d}{dt} \sigma_n(t) &= -r_n(t) = \Delta \log_2(1 - \sum_j h_{nj}(t)) \\ &\approx -\frac{\Delta}{\log(2)} \sum_j h_{nj}(t) \end{aligned}$$

In our system, at any given time, the base stations can adapt the bit rates $H(t) = \{h_{nj}(t)\}$, provided that they can solve the power allocation problem. In view of Proposition 7.3.2, it is sufficient to guarantee that:

$$\forall j, \quad \sum_n h_{nj}(t) \frac{I(X_n)}{L(X_n, Y_j)} < 1, \quad (7.33)$$

indeed, the spectral radius of a substochastic matrix is upper bounded by 1. Since we have defined the workload as an atomic measure, along this line, we also define the policy enforced at time t by the base station j as an atomic measure with atoms at users' locations:

$$\pi_j(t) = \sum_n h_{nj}(t) \frac{I(X_n)}{L(X_n, Y_j)} \delta_{X_n}.$$

From Equation (7.33), the constraint on the policy is: $\int_{\mathbb{R}^2} \pi_j(t)(dx) < 1$. All the computation is unchanged if we replace the strict inequality in this last equation by a less or equal. For a subset of the plane, $\pi_j(t)(B)$ is the ratio of processing power that the base station dedicates to users in B . Note in particular that for a set B :

$$\text{if } W_t(B) = 0 \text{ then for all } j, \pi_j(t)(B) = 0, \quad (7.34)$$

which states that the base stations are sharing their processing power among active users. From a mathematical point of view, it asserts that the policy is absolutely continuous with respect to W .

From the discussion above, if the policy enforced at time t depends only on the workload at time t , the policy enforced by the base stations is a policy in the sense given in Chapter 6.

We can then rewrite the Workload Equation (7.32) in a bounded set B , for $t, h \in \mathbb{R}_+$:

$$W_{t+h}(B) = W_t(B) + \int_t^{t+h} \int_B \sigma_{s,x} A(ds \times dx) - \frac{\Delta}{\log(2)} \sum_j \int_t^{t+h} \int_B \frac{L(x, Y_j)}{I(x)} \pi_j(s)(dx) ds, \quad (7.35)$$

in words: the total number of bits at time $t+h$ brought by users in the set B is equal to the total number of bits which was brought at time t plus the bits brought by the newcomers in set B between t and $t+h$ and minus all the work done by the base stations in this set during this time.

We recognize exactly an evolution equation given by Equation (6.5). We can thus apply the results of the previous chapter to the macrodiversity scenario on the downlink.

For TDMA networks, stability considerations are addressed by Bonald et al. in [34], [33]. In [34], a single cell is considered, they derive the stability region and they address the problem of fairness among active users. In [33], they include to their model the mobility of users inside the cell and they prove some bounds on the total workload.

7.4.3 Canonical Example

In order to fix ideas, we illustrate our results on a classical example of CDMA network. Suppose that the base stations of our networks are located on an regular hexagonal grid. The distance between two adjacent sites is L km. A sequence of users arrives in the network. We suppose that this user arrival process is an homogeneous space-time point process of intensity $\lambda > 0$. λ is the spatial density of newcomers in a time units. We suppose that each user wants to receive in mean σ bits of data from the base stations.

We assume that the available bandwidth on the channel is Δ Hz. The attenuation function (or path loss function) from an emitting point y to a receiving point x supposed to be equal to: $K|x-y|^{-\alpha}$, where K is a positive constant and $|\cdot|$ denotes the Euclidean distance.

From Theorem 6.2.1, we deduce the following:

$\lambda < \lambda_c$ then the network is stable, if $\lambda > \lambda_c$ the network is unstable.

The analytical expression of the critical density λ_c is given by Proposition 6.4.6, using an approximation given in Karray et al. [99], [14]:

$$\lambda_c \approx \frac{2}{\log(2)\sqrt{3}} \frac{\Delta}{\sigma L^2} \left(1 + \frac{0.94}{\alpha - 2}\right)^{-1}. \quad (7.36)$$

For $\Delta = 1$ MHz, $L = 1$ km, $\alpha = 4$, $\sigma = 1$ Mo, the above formula gives: $\lambda_c \approx 510$ users per square kilometer and per hour. An other interpretation of this numerical result gives a good insight. $\lambda\sigma$ is the mean number of bits pumped per surface unit per time unit: this is the bit rate per surface unit of our network. For our numerical example, the maximal rate per surface unit is: 1,13 megabits per square kilometer and per second.

From Proposition 6.4.2, λ_c is the same for the network in macrodiversity and for the traditional hexagonal cell networks. Therefore, macrodiversity has not increased the maximal density of users the system is able to handle.

If instead of the hexagonal grid, we had supposed that the stations sites was a Poisson point process then, by Proposition 6.4.7:

$$\lambda_c = 0. \text{ a.s.}$$

The system is never stable, whatever the density of base stations is.

7.4.4 Slow Fading and Mobility

Framework. We now extend our stability result to a more complex model. We suppose that the attenuation depends on the time. Namely we suppose that at time t , the attenuation function is equal to: $L(x, Y_j; t)$.

The shot-noise I depends on the time and is then equal to $I(x; t) = \sum_k L(x, Y_k; t)$. Let $\mu_j(x; t) = \frac{L(x, Y_j; t)}{I(x; t)}$ be the processing rate at time t for the base station j . For technical reasons, we require that for all j , the mappings $(\mu_j(\cdot; t))_{t \in \mathbb{R}}$ are taking value into a *countable set* of processing rates mappings: $(\mu_j^n)_{n \in \mathbb{N}}$.

We define $Z_j(t) \in \mathbb{N}$ as the random variable which drives the state of the processing rate : $\mu_j(x; t) = \mu_j^{Z_j(t)}(x)$. We assume that the random variables $Z_j(t)$ are *time-ergodic*. Let $p_j^n = P(\mu_j(\cdot; t) = \mu_j^n) = P(Z_j(t) = n)$.

Following the results of Chapter 6, we define the following sets in our time varying setting:

$$\mathcal{F} = \left\{ f = (x \mapsto f_{j,n}(x))_{j \in \mathbb{N}} \text{ such that, } \forall j, n, \lambda(dx)\text{-a.e. } \sum_{j,n} f_{j,n}(x) = 1 \text{ and } f_{j,n}(x) \geq 0 \right\}.$$

$$\mathcal{N}^s = \left\{ A \in \mathcal{N} : \exists f \in \mathcal{F} \text{ such that: } \forall j, n, \int_{\mathbb{R}^2} \frac{E_A^{0,x}(\sigma_{0,x}) f_j(x)}{\mu_j^n(x)} \lambda(dx) < p_j^n \frac{\Delta}{\log(2)} \right\},$$

and $\bar{\mathcal{N}}^s$ is defined similarly with \leq instead of $<$. The interpretation follows: $f_{j,n}(x)$ is the proportion of service which is performed by the base station j for a typical user arriving in x when the station is in state n . From Theorem 6.2.1.

- if $A \in \mathcal{N}^s$, then there exists a stable policy,
- if there is a stable policy then $A \in \bar{\mathcal{N}}^s$.

Slow Fading. There are two types of fading in wireless communications, slow and fast fading. Fast fading is caused by multi-path propagation of the signal from a base station to a user. In a CDMA setting, fast fading is not a relevant feature. Fast fading is relevant for TDMA schemes and can be used in opportunistic scheduling. On the contrary, slow fading has an impact in CDMA networks. Slow fading or shadowing is due to the random environment between base stations and users. For example moving obstacles on the propagation path. Fading can be characterized by a collection of random field processes of mean one: $G_j(t, x) \in \mathbb{R}_+$. The attenuation function is then taken to be equal to:

$$L(x, Y_j; t) = G_j(t, x) l(|x - Y_j|),$$

where $l(r)$ is the usual radial attenuation function used in the simple model.

For slow fading, $(G_j(\cdot; t))_{j \in \mathbb{N}}$ is well approximated by independent log-normal fields. A model for its correlation function is given by Gudmundson in [82].

Mobility. Our framework can also be used to include a simple type of mobility. Consider a random field process with value on \mathbb{R}^2 :

$$X(x, t) \in \mathbb{R}^2.$$

$X(x, t)$ receives the following interpretation: $X(x, t)$ is the position at time t of all users which arrived in x at any time. In particular the user (T_n, X_n) is located in $X(t, X_n)$ at time t . Note then that X_n is not anymore the position of the user n . This model is not fully realistic but leads to a computable stability region. The attenuation function is then taken to be equal to:

$$L(x, Y_j; t) = l(|X(x, t) - Y_j|).$$

As a simple example, $X(x, t)$ could take a few distinct value around x .

Part III

Spatial Point Process

Chapter 8

The dead leaves model : a general tessellation modeling occlusion

Résumé Nous étudions un exemple particulier de tessellation aléatoires, le modèle de *feuilles mortes*. Ce modèle, étudié initialement par l'école de morphologie mathématique, est défini par une surimposition séquentielle de fermés aléatoires. Il fournit un outil naturel pour étudier le phénomène d'occlusion, ingrédient essentiel dans la formation d'images visuelles. Nous généralisons des résultats de G. Matheron, et en particulier nous calculons la probabilité que n compacts soient inclus dans des *parties visibles*. Ce résultat donne une caractérisation de la distribution de la frontière de la tessellation des feuilles mortes.

Abstract We study a particular example of general random tessellation, the *dead leaves* model. This model, first studied by the mathematical morphology school, is defined as a sequential superimposition of random closed sets. It provides the natural tool to study the occlusion phenomenon, essential ingredient in the formation of visual images. We generalize results from G. Matheron, and in particular we compute the probability for n compact sets to be included in *visible parts*. This result characterizes the distribution of the boundary of the dead leaves tessellation.

8.1 Introduction

The dead leaves model has been introduced by Matheron in [118]. This model results from sequential superimposition of random sets. As such, it provides the natural tool for studying the non-linear *occlusion* phenomena, of great importance in image modeling and processing. However, to the best of our knowledge, this model has not been systematically investigated, and even its mere definition lacks some precision. Our purpose in this chapter is twofold: first to provide a rigorous definition of the model as a random tessellation, second to give new proofs or extensions of Matheron’s results in the framework of Palm calculus.

A first motivation to study this model comes from applications. Amongst existing stochastic models for natural images, the dead leaves is the only one whose definition agrees with their physical formation. Several recent studies have demonstrated the ability of specific dead leaves models to reproduce most known statistics of natural images, see Ruderman [140], Alvarez, Gousseau and Morel [8], Lee, Mumford and Huang [112]. The model has also been proposed as a tool to resample random fields for texture synthesis, see Gousseau [78]. Other examples of application come from material sciences, see Jeulin [97] and Gille [73].

As a second motivation, let us stress that the dead leaves model provides non-trivial examples of general random tessellations, in the sense that their cells are general closed sets. In particular, they are not necessarily polygonal, connected or convex, as it is the case for the most popular tessellation models, such as Poisson flats, Voronoi or Delaunay tessellations. Note that non-convex and non-polygonal cells are encountered in the case of Johnson-Mehl tessellation (see e.g. Kendall, Mecke and Stoyan [102]), but that there are relatively few such examples. Therefore, there are few studies of “general” tessellations, even though classical formulae originally proved in the convex and polygonal case have been shown to hold in more general contexts, see Stoyan [147], Weiss and Zähle [160] and Cowan and Tsang [52].

In Section 8.2 we first recall some facts on random closed sets and slightly reformulate Möller [125] and Stoyan [147] to define random tessellations and typical cell distributions. In Section 8.3 we define the dead leaves model as a random tessellation obtained from an initial Poisson process, and give some of its elementary properties. Then, in Section 8.4, we generalize results from G. Matheron. In order to do so in a rigorous way, we make use of point processes theory through the systematic use of Palm calculus. We first give the probability for n compact sets to be included in n different visible parts, a result which completely characterizes the distribution of the boundary of our model as a random closed set. Then we compute the distribution of “objects” that remain completely visible. Eventually, we reobtain in the Palm calculus framework a nice result from G. Matheron giving the length distribution of the intersection of objects with a line of fixed direction, stating in particular that its expectation is divided by two as a result of occlusion.

Previous work. The dead leaves model was introduced in Matheron [118], an internal note written in an informal style, but containing all basic ideas. The model is defined as the superimposition of infinitesimal boolean models, and formula for the probability of a compact set to be included in a visible part and for the distribution of completely visible parts, among other things, are derived. Most of these definitions and results are stated in the book by Serra [143]. Jeulin further studied this model in [96], still with the same infinitesimal formalism, and gave an explicit formula for the joint probability of two compact sets to be included in visible parts. In [95] he generalizes the model to the case of random functions and extend to this setting formulae for the distribution of visible parts and for inclusion probabilities. Cowan and Tsang, in a very interesting paper [51], make use of mean value formulae for tessellations to derive the expectations of various quantities such as the number of connected components of visible parts or the length of their boundaries per surface unit.

8.2 Basic definitions

8.2.1 Closed Sets and Tessellations

Let \mathcal{F} , \mathcal{G} and \mathcal{K} be respectively the sets of all closed, open and compact sets of \mathbb{R}^d , $d \geq 1$. Let us denote for any $A \subset \mathbb{R}^d$,

$$\mathcal{F}^A = \{F \in \mathcal{F} : F \cap A = \emptyset\} \quad \text{and} \quad \mathcal{F}_A = \{F \in \mathcal{F} : F \cap A \neq \emptyset\}.$$

The Borel σ -field $\mathcal{B}_{\mathcal{F}}$ on \mathcal{F} is generated by the basis of open sets $\{\mathcal{F}^K, K \in \mathcal{K}; \mathcal{F}_G, G \in \mathcal{G}\}$. Borel sets are defined on \mathcal{G} and \mathcal{K} in a way similar to those of \mathcal{F} , see Matheron [119]. A random closed set (RACS) of \mathbb{R}^d is a measurable function from a probability space (Ω, \mathcal{S}, P) into $(\mathcal{F}, \mathcal{B}_{\mathcal{F}})$. For any sets A and B , we will denote

$$A \ominus B = \{x \in \mathbb{R}^d : x + \check{B} \subset A\} \quad \text{and} \quad A \oplus B = \{x + y : x \in A, y \in B\},$$

where $\check{B} = \{-x, x \in B\}$. $A \ominus \check{B}$ is called the erosion of A by B , and $A \oplus \check{B}$ the dilation of A by B . Measurability properties of these operators are established in Matheron [119].

A σ -finite measure on $\mathcal{F}' := \mathcal{F} \setminus \{\emptyset\}$ (endowed with its Borel σ -algebra $\mathcal{B}_{\mathcal{F}'}$) is a measure taking finite values on \mathcal{F}_K , for all $K \in \mathcal{K}$, see [119]. We denote by $\mathcal{N}_{\mathcal{F}'}$ the set of σ -finite counting measures on $(\mathcal{F}', \mathcal{B}_{\mathcal{F}'})$. For all $M \in \mathcal{N}_{\mathcal{F}'}$, we write $M = \sum_i \delta_{F_i}$, where δ_{F_i} is the unit mass measure at point F_i . The *boundary* of M is defined as $\partial M = \bigcup_i \partial F_i$, where ∂F_i denotes the topological boundary of F_i . A point process on \mathcal{F}' is a measurable function from a probabilistic space to $(\mathcal{N}_{\mathcal{F}'}, \mathcal{B}_{\mathcal{N}_{\mathcal{F}'}})$, where $\mathcal{B}_{\mathcal{N}_{\mathcal{F}'}}$ is the usual σ -field on $\mathcal{N}_{\mathcal{F}'}$, see e.g. Daley and Vere-Jones [55].

Following Stoyan [147], a tessellation of \mathbb{R}^d is defined as follows.

Definition 8.2.1 *Let $T = \sum_i \delta_{F_i} \in \mathcal{N}_{\mathcal{F}'}$. We say that T is a tessellation of \mathbb{R}^d if*

$$(i) \quad \bigcup_i F_i = \mathbb{R}^d.$$

$$(ii) \quad \text{for all } i \neq j, \text{Int}F_i \cap F_j = \emptyset, \text{ where } \text{Int}F \text{ denotes the interior of } F,$$

or equivalently if $\{(\text{Int}F_i)_i, \partial T\}$ is a partition of \mathbb{R}^d .

Note that $T \in \mathcal{N}_{\mathcal{F}'}$ implies that the number of cells F_i s hitting a compact set is finite. This condition is added in the original definition in [147], where the F_i s are marks of a point process $N = \sum_i \delta_{x_i}$ on \mathbb{R}^d , where x_i is called the *centroid* of F_i . The centroids are unimportant for the definition of a tessellation but they are quite useful for defining *the typical cell distribution* as we will recall below.

Let \mathcal{T} be the set of all tessellations in $\mathcal{N}_{\mathcal{F}'}$. Expressing assertions (i) and (ii) as limits of the elementary sets operations $(F, F') \mapsto F \cup F'$, $(F, F') \mapsto F \cap F'$ and $F \mapsto \partial F$, whose measurability may be found in [119, Section 1-2], one easily gets that $\mathcal{T} \in \mathcal{B}_{\mathcal{N}_{\mathcal{F}'}}$. A random tessellation of \mathbb{R}^d is then defined as a point process T on \mathcal{F}' , such that $T \in \mathcal{T}$ almost surely (a.s.). Classical examples of random tessellations (see the references in [102, Chapter 10] and [128]) include Poisson hyperplanes processes, Delaunay, Voronoi and Johnson-Mehl tessellations. A standard approach (see e.g. [9], [50], [120], [125] or [102]), which applies in these examples, is to define ∂T directly as a RACS without considering the underlying random tessellation. However, it is not always possible to recover the F_i 's from ∂T (they may not be connected, see [52] and Remark 8.3.7 below for a precise example).

8.2.2 Typical Cell distribution

In [125] a typical cell is defined by using the Palm distribution of a simple marked point process $N = \sum_i \delta_{x_i, F_i}$ of points in \mathbb{R}^n with marks in \mathcal{F}' , stationary with respect to shifts $N \mapsto \sum \delta_{x_i-x, F_i-x}$, $x \in \mathbb{R}^d$. More precisely, let us denote by μ the intensity of N , which we assume to be finite, and by \mathbb{P}_N^0 its Palm distribution (see in Appendix B.2). Let x_0 be the point nearest to the origin and F_0 be its corresponding cell. Then the *typical cell distribution* is defined on the σ -field \mathcal{I} of all translation-invariant events in $\mathcal{B}_{\mathcal{F}'}$ by $\chi \mapsto \mathbb{P}_N^0(F_0 \in \chi)$, $\chi \in \mathcal{I}$. A result in [125], proven in the case of tessellations whose cells are bounded polytopes, can be easily extended as follows.

Proposition 8.2.2 *Let B be a Borel set in \mathbb{R}^d such that*

$$0 < \nu(F_i \oplus B) < +\infty \quad \text{for all } i \text{ a.s.}, \quad (8.1)$$

where ν is the Lebesgue measure on \mathbb{R}^n . Then $\mu = \mathbb{E} \sum_i \frac{\mathbb{1}(0 \in F_i \oplus B)}{\nu(F_i \oplus B)}$ and

$$\mathbb{P}_N^0(F_0 \in \chi) = \frac{1}{\mu} \mathbb{E} \sum_i \frac{\mathbb{1}(0 \in F_i \oplus B) \mathbb{1}(F_i \in \chi)}{\nu(F_i \oplus B)}, \quad \chi \in \mathcal{I}.$$

When starting from a stationary point process $M = \sum_i \delta_{F_i}$ on \mathcal{F}' , a marked point process N can be obtained by constructing points $x_i = \Delta(F_i)$, where Δ is such that $\Delta(F_i - x) = \Delta(F_i) - x$. Classical examples for Δ include the set-centroid, the median point or the extremal point in a given direction. Observe that, under Condition (8.1), it is always possible to define such a set-centroid by taking for each coordinate the median of the marginal measure of ν restricted to $F_i \oplus B$; for instance, the first coordinate is then defined as the smallest x such that $\nu((F_i \oplus B) \cap (-\infty, x] \times \mathbb{R}^{d-1}) \geq \nu(F_i \oplus B)/2$. As noticed by [125], the typical cell distribution should not depend on the choice of the x_i s, which is insured by Proposition 8.2.2 provided that one can find a Borel set B for which (8.1) is fulfilled. This will be the case for the dead leaves model considered below.

In order to define the typical cell of a tessellation, assume that

$$\begin{cases} 0 < \nu(F_i) < \infty \\ \nu(\partial F_i) = 0 \end{cases} \quad \text{for all } i \text{ a.s.} \quad (8.2)$$

Note that the first condition above is Condition (8.1) with $B = \{0\}$. The second condition enables to define, almost everywhere, $F_{\{x\}}$ as the cell to which the point x belongs. By stationarity of N , $F_{\{0\}}$ is defined a.s. Applying Proposition 8.2.2, we then get

$$\mu = \mathbb{E} \frac{1}{\nu(F_{\{0\}})} \quad \text{and} \quad \mathbb{P}_N^0(F_0 \in \chi) := \frac{1}{\mu} \mathbb{E} \frac{\mathbb{1}(F_{\{0\}} \in \chi)}{\nu(F_{\{0\}})}, \quad \chi \in \mathcal{I}. \quad (8.3)$$

We thus obtain the formula of the typical cell distribution derived in [120], [125] (when the F_i 's are bounded polytopes) and [50] (when the F_i 's are uniformly bounded polytopes).

We end this section with a limit theorem. Let $B_n = B(0, r_n)$ be the ball centered at 0 of radius r_n where $r_n \rightarrow \infty$. Let $(A_n)_{n \in \mathbb{N}}$ be any increasing sequence of compact convex sets such that for all n , $B_n \subset A_n$. The individual ergodic theorem (Proposition 10.2.II of [55] and in Appendix, Proposition B.5) easily yields the following.

Proposition 8.2.3 *If N is ergodic and satisfies (8.2), then, for all $\chi \in \mathcal{I}$,*

$$\lim_n \frac{\sum_i \mathbb{1}(F_i \in \chi) \frac{\nu(F_i \cap A_n)}{\nu(F_i)}}{\sum_i \frac{\nu(F_i \cap A_n)}{\nu(F_i)}} = \mathbb{P}_N^0(F_0 \in \chi) \quad \text{a.s.} \quad (8.4)$$

Equation (8.4) is a weighted average, where each F_i has a weight equal to its proportion included in A_n . From a statistical point of view, (8.4) can be used for deriving a strongly consistent estimator of $\mathbb{P}_N^0(F_0 \in \chi)$ for a given $\chi \in \mathcal{I}$. Under stronger hypothesis on the cells, there may be different sequences having the same limit as in (8.4). For example, if the cells are uniformly bounded (as in [50]), Relation (8.4) implies, a.s.,

$$\mathbb{P}_N^0(F_0 \in \chi) = \lim_n \frac{\sum_i \mathbb{1}(F_i \in \chi) \mathbb{1}(F_i \subset A_n)}{\sum_i \mathbb{1}(F_i \subset A_n)} = \lim_n \frac{\sum_i \mathbb{1}(F_i \in \chi) \mathbb{1}(F_i \cap A_n \neq \emptyset)}{\sum_i \mathbb{1}(F_i \cap A_n \neq \emptyset)}.$$

Sufficient conditions under which these equalities hold are studied in [52].

8.3 The dead leaves model

8.3.1 Definition

The dead leaves model is obtained through sequential superimposition of random objects falling on \mathbb{R}^d . Let $\sum_{i \in \mathbb{N}} \delta_{x_i, t_i}$ be a homogeneous Poisson point process on the half-space $\mathbb{R}^d \times (-\infty, 0]$ with intensity one. Let P be a probability measure on $(\mathcal{F}, \mathcal{B}_{\mathcal{F}})$, and $(X_i)_{i \in \mathbb{N}}$, be i.i.d. random variables on \mathcal{F} with distribution P and independent of the Poisson point process above. Equivalently, $\Phi = \sum_i \delta_{x_i, t_i, X_i}$ is a Poisson point process on $\mathbb{R}^d \times (-\infty, 0] \times \mathcal{F}$ with intensity measure $\nu(dx)dtP(dX)$.

We write $(\Omega, \mathcal{S}, \mathbb{P})$ for the probabilistic space on which Φ is defined and \mathbb{E} for the expectation with respect to \mathbb{P} . From now on, X will always denote a random variable on \mathcal{F} with distribution P independent of all other variables, and E will denote the expectation with respect to P .

Definition 8.3.1 For all $i \in \mathbb{N}$, the random closed set $x_i + X_i$ is called a leaf and

$$V_i = (x_i + X_i) \setminus \left(\bigcup_{t_j \in (t_i, 0)} (x_j + \text{Int}X_j) \right) \quad (8.5)$$

is called a visible part.

From now on we assume that X satisfies the following three conditions:

- (C-1) For all $K \in \mathcal{K}$, $E\nu(X \oplus K) < +\infty$,
- (C-2) There exists a ball B with strictly positive radius, such that $E\nu(X \ominus B) > 0$.
- (C-3) X is a regular closed set, i.e. X is the closure of its interior, P -a.s.

Proposition 8.3.2 We denote by M the point process on \mathcal{F}' obtained by removing all sets with empty interior in the collection $\{V_i\}$, that is,

$$M = \sum_i \mathbb{1}\{\text{Int}V_i \neq \emptyset\} \delta_{V_i}. \quad (8.6)$$

Then M is a random tessellation of \mathbb{R}^d . Moreover $N = \sum_i \mathbb{1}\{\text{Int}V_i \neq \emptyset\} \delta_{x_i, V_i}$ is stationary, mixing and has finite intensity.

Remark 8.3.3 The condition $\text{Int}V_i \neq \emptyset$ in the definitions of M and N is adopted for convenience as it eliminates visible parts with zero d -dimensional Lebesgue measure. The question arises whether $M' := \sum_i \mathbb{1}\{V_i \neq \emptyset\} \delta_{V_i}$ also verifies such property. For simple examples of X , it is easily shown that $M = M'$ a.s. but we do not know whether this equality is true under the general assumptions (C-1)-(C-3). In any case, because (8.5) implies that $\partial V_i \subset \cup_{t_j > t_i} \partial\{\text{Int}V_j\}$, we always have $\partial M = \partial M'$.

In order to prove Proposition 8.3.2 we will make use of the following two lemmas. The first one, which is easy to prove by referring to the definition of the intensity of the Poisson point process Φ , will be repeatedly needed in the sequel.

Lemma 8.3.4 *Let K be a bounded Borel set, $-\infty < s_1 < s_2 < 0$ and define*

$$\begin{aligned}\Phi_K(s_1, s_2) &:= \sum_i \mathbb{1} \{t_i \in (s_1, s_2] \text{ and } K \subset x_i + X_i\} , \\ \Phi^K(s_1, s_2) &:= \sum_i \mathbb{1} \{t_i \in (s_1, s_2] \text{ and } K \cap x_i + X_i \neq \emptyset\} .\end{aligned}$$

$\Phi_K(t_1, t_2)$ and $\Phi^K(t_1, t_2)$ are Poisson random variables with respective means $(t_2 - t_1)E\nu(X \ominus \check{K})$ and $(t_2 - t_1)E\nu(X \oplus \check{K})$.

Lemma 8.3.5 *If K is a Borel set of \mathbb{R}^d such that $E\nu(X \ominus \check{K}) > 0$, then K is almost surely covered by some leaf $x_i + X_i$. As a consequence, any bounded set is a.s. covered by a finite number of leaves.*

Proof. Let us fix $t < 0$. Using Lemma 8.3.4, the probability $\mathbb{P}(\Phi_K(t, 0) = 0)$ that none of the leaves $x_i + X_i$ with $t < t_i < 0$ satisfies $K \subset x_i + X_i$ is $\exp(-tE\nu(X \ominus \check{K}))$, which yields the first assertion. Now let B be a ball such that Condition (C-2) is satisfied, that is $E\nu(X \ominus B) > 0$. Since any bounded set K is covered by a finite number of balls with the same radius as B , it also follows that K is covered by $\cup_{t_i > T}(x_i + X_i)$ for some $T < 0$. \square

Proof. [Proof of Proposition 8.3.2] Let us now show that, \mathbb{P} -a.s., $M \in \mathcal{N}_{\mathcal{F}'}$. In fact, we show that, \mathbb{P} -a.s., $M' := \sum_i \mathbb{1}(V_i \neq \emptyset)\delta_{V_i} \in \mathcal{N}_{\mathcal{F}'}$ (which implies $M \in \mathcal{N}_{\mathcal{F}'}$), that is, that only a finite number of visible parts V_i may intersect a given compact set K . By Lemma 8.3.5, \mathbb{P} -a.s., there exists a negative T such that K is covered by leaves $x_i + X_i$ satisfying $t_i > T$. It follows that the visible parts intersecting K correspond to leaves falling after time T . The number of such leaves is thus $\Phi^K(T, 0)$, which is finite \mathbb{P} -a.s. by Lemma 8.3.4 with Condition (C-1). To show that M is a random tessellation, we now verify that it satisfies Conditions (i) and (ii) of Definition 8.2.1. Let $T < 0$. Since $\cup_{t_i > T} V_i \subseteq \cup_{t_i > T}(x_i + X_i)$ and since a point in $x_i + X_i$ either belongs to V_i or to $x_j + \text{Int}X_j$ for some $t_j > t_i$, we have $\cup_{t_i > T}(x_i + X_i) = \cup_{t_i > T} V_i$. Therefore by Lemma 8.3.5 we get, \mathbb{P} -a.s., $\cup_i V_i = \mathbb{R}^d$. We observe from Condition (C-3) that $\text{Int}V_i = (x_i + \text{Int}X_i) \cap \{\cap_{t_j > t_i}(x_j + X_j)^c\}$. It follows that $\text{Int}V_i = \emptyset$ if and only if $V_i \subset \cup_{t_j > t_i}(x_j + X_j) = \cup_{t_j > t_i} V_j$. Indeed, the “if” part is obvious, while the “only if” part is obtained by observing that $x_i + \text{Int}X_i \subseteq \cap_{t_j > t_i}(x_j + X_j)$ implies the same inclusion for $\overline{x_i + \text{Int}X_i} = x_i + X_i \supseteq V_i$. Finally, consider a realization of Φ such that $M' \in \mathcal{N}_{\mathcal{F}'}$ and $\cup_i V_i = \mathbb{R}^d$, which happens \mathbb{P} -a.s., as we have shown above. Pick any point $x \in \mathbb{R}^d$. Since $M' \in \mathcal{N}_{\mathcal{F}'}$, there exists a positive and finite number of indices i such that $x \in V_i$ and hence one i such that $x \in V_i$ and $x \notin V_j$ for all $t_j > t_i$. By the above characterization, this implies $\text{Int}V_i \neq \emptyset$. Hence $\cup\{V_i : \text{Int}V_i \neq \emptyset\} = \mathbb{R}^d$, that is, M satisfies Condition (i) of Definition 8.2.1. Condition (ii) of Definition 8.2.1 is easily obtained from (8.5) and (C-3) by considering the cases $t_j > t_i$ and $t_i > t_j$ successively.

Next we show stationarity and mixing property. Define

$$\Pi : \sum_i \delta_{x_i, t_i, X_i} \mapsto \sum_i \mathbb{1}(\text{Int}V_i \neq \emptyset)\delta_{x_i, V_i} . \quad (8.7)$$

Recall that \mathbb{P} denotes the distribution of the initial (homogeneous) Poisson point process Φ , so that $\mathbb{P}_\Pi = \mathbb{P} \circ \Pi^{-1}$ is the distribution of N . Further observe that translations on the x_i 's correspond to translations on the V_i 's through Π . It follows that the stationarity and the mixing property of N (with respect to shifts $N \rightarrow \sum \delta_{x_i - x, V_i - x}$, $x \in \mathbb{R}^d$) are inherited from Φ .

It remains to prove that the intensity μ of N is finite. For all $T < 0$, let $N_T := \sum \delta_{x_i, V_i} \mathbb{1}(t_i > T, \text{Int}V_i \neq \emptyset)$. Let μ_T denote the intensity of N_T ; we have $\mu_T \leq \mathbb{E} \sum \mathbb{1}(x_i \in [0, 1]^n, t_i > T) \leq -T$, hence μ_T is finite. By monotone convergence, since μ_T is non-decreasing as T decreases to $-\infty$, $\mu = \lim_{T \rightarrow -\infty} \mu_T$. Below we provide a uniform upper bound for μ_T , which will thus apply to μ and conclude the proof. Using Proposition 8.2.2 with B given by (C-2), we get

$$\begin{aligned} \mu_T &= \mathbb{E} \sum_i \frac{\mathbb{1}(0 \in V_i \oplus B)}{\nu(V_i \oplus B)} \mathbb{1}(t_i > T, \text{Int}V_i \neq \emptyset) \\ &\leq \nu(B)^{-1} \mathbb{E} \sum_i \mathbb{1}\{0 \in x_i + X_i \oplus B, 0 \notin \cup_{t_i > t}(x_i + \text{Int}X_i \ominus B)\}, \end{aligned}$$

where the inequality follows both from $\nu(V_i \oplus B) \geq \nu(B)$, and $V_i \oplus B \subset (x_i + X_i \oplus B) \setminus \cup_{t_i > t}(x_i + \text{Int}X_i \ominus B)$, which in turn follows from (8.5) and standard properties of morphological operations. Now, Campbell's theorem and Slivnyak's theorem yield

$$\mu_T \leq \frac{1}{\nu(B)} \int_{[T, 0] \times \mathbb{R}^d \times \mathcal{F}} \mathbb{1}(0 \in x + X \oplus B) \mathbb{P}(0 \notin \cup_{t_i > t}\{x_i + \text{Int}X_i \ominus B\}) dt \nu(dx) P(dX).$$

Noticing that $\cup_{t_i > t}(x_i + \text{Int}X_i \ominus B)$ is a boolean model with intensity t , we thus get

$$\mu_T \leq \frac{1}{\nu(B)} E\nu(X \oplus B) \int_T^0 \exp(tE\nu(X \ominus B)) dt \leq \frac{1}{\nu(B)} \frac{E\nu(X \oplus B)}{E\nu(X \ominus B)},$$

which is finite under (C-1) and (C-2). \square

In the definition of M , we assume that $\sum_i \delta_{x_i, t_i}$ has intensity one. However, rescaling the x_i 's is equivalent, up to a global rescaling of the model, to a rescaling of X and any order preserving modification of the t_i 's is unimportant as seen from the definition.

Definition 8.3.6 *The point process M defined in Proposition 8.3.2 is called the dead leaves tessellation associated with the RACS X .*

Remark 8.3.7 The dead leaves model clearly shows the necessity to define a tessellation through its cells, and not only its boundary. Indeed, visible parts defined by (8.5) are not necessarily connected. *see Figure 8.2.*

8.3.2 Perfect simulation

The term ‘‘dead leaves model’’ originates from a more natural definition which consists in putting each new leaf *above* the previous ones and then considering the stationary distribution of this Markov process. Let K be a compact set of \mathbb{R}^2 . A classical ‘‘coupling from the past’’ argument enables perfect simulation of the stationary distribution restricted to K , by putting each new leaf *below* the already fallen leaves until K is completely covered (see the illustrating web applet [101]). This elegant argument was first introduced for the dead leaves model in [152]. In Figures 8.1 and 8.2 we show simulations of the model computed this way. To visualize the model each grain is allocated a random gray level.

8.3.3 Regularity properties of visible parts

Some almost sure regularity results about visible parts are a consequence of the following remark. From Lemma 8.3.4, a visible part V_i is \mathbb{P} -a.s. equal to a leaf $x_i + X_i$ to which a *finite* number of other leaves have been removed. Now remark that if A is a closed set and B an open set, then $\partial(A \setminus B) = (\partial A \setminus B) \cup (\partial B \cap A)$. It follows that ∂V_i is a finite union of sets, each of

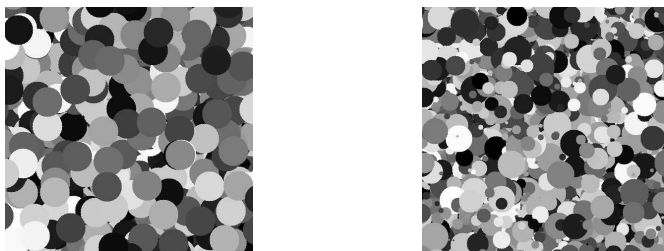

Figure 8.1: on the left, simulation of a dead leaves model, where the grain X_0 is a disk with constant radius. On the right, simulation of a dead leaves model, where the grain X_0 is a disk with a uniformly distributed radius.

which is included in $x_j + \partial X_j$ for some $t_j \geq t_i$ so that some regularity properties on ∂X are inherited by the ∂V_i 's. Note however that possible convexity of the grain X is not inherited by the V_i 's.

Proposition 8.3.8 *We have $\nu(\partial M) = 0$ \mathbb{P} -a.s. if and only if $\nu(\partial X) = 0$ P -a.s.*

Proof. The discussion above implies that $\nu(\partial V_i) \leq \sum_{t_j \geq t_i} \nu(\partial X_i)$ \mathbb{P} -a.s. Since $\partial M = \cup_i \partial V_i$, $\nu(\partial X) = 0$ P -a.s. implies $\nu(\partial M) = 0$ \mathbb{P} -a.s.

Now, $\nu(\partial M) = 0$ \mathbb{P} -a.s. implies $\nu(\partial V_i) = 0$ for all i and in particular for all cells such that $V_i = x_i + X_i$ (the so-called *relief cells* studied in the forthcoming Section 8.4.2). We will see in Remark 8.4.6 below that this in turn implies $\nu(\partial X) = 0$ P -a.s. \square

If $\text{Int}V_i \neq \emptyset$ then $\nu(V_i) > 0$. Besides, $V_i \subset x_i + X_i$ is bounded \mathbb{P} -a.s. by (C-1). If in addition $\nu(\partial X) = 0$ P -a.s., then we are in the framework of Section 8.2.2 for tessellations. When $\nu(\partial X) = 0$, one says that X is ν -regular, a property that neither implies nor is implied by (C-3). It is easy to find a set X which is ν -regular and not closed regular, for instance a set containing isolated points. To construct a closed regular set which is not ν -regular, one can proceed as follows (for $d \geq 2$). Let $\tilde{\nu}$ be the $(d-1)$ -dimensional Lebesgue measure on the hyperplane $\{\mathbf{x} = (x_1, \dots, x_d) : x_1 = 1/2\}$. Then there exists a homeomorphism $h : [0, 1]^d \rightarrow [0, 1]^d$ such that $\nu + \tilde{\nu} = \nu \circ h$, see [76]. It follows that $X := h([0, 1/2]^d)$ is not ν -regular although it is closed regular.

8.4 Some characteristics of the dead leaves tessellation

8.4.1 Inclusion probabilities and boundary distribution

The main practical result from the original paper by Matheron introducing the dead leaves model [118] is concerned with a functional, defined on compact sets of the plane, equal to the probability that a given compact set is included in a visible part of the model. It is shown that,

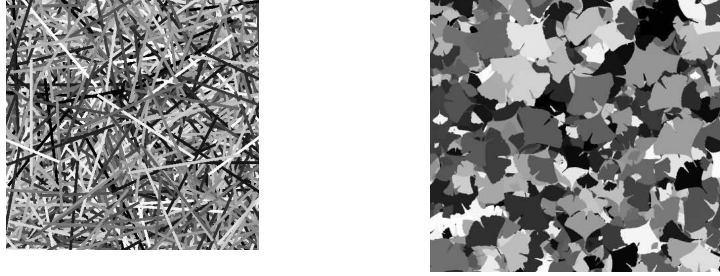

Figure 8.2: simulations of dead leaves models. Left: the grain X_0 is a rectangle with a direction uniformly distributed in $[0, \pi]$. Right: the grain is a more complicated shape, the distribution of its size being uniform.

for a non-empty $K \in \mathcal{K}$,

$$\mathbb{P}(K \subset \text{Int}V_i \text{ for some } i \in \mathbb{N}) = \frac{E\nu(\text{Int}X \ominus \check{K})}{E\nu(X \oplus \check{K})}. \quad (8.8)$$

Considering simple examples of possible K 's such as bipoints or segments leads to valuable geometric information on the model.

In what follows, we generalize this result by taking interest in the probability that n compact sets are included in n distinct visible parts. We define

$$Q^{(n)}(K_1, \dots, K_n) = \mathbb{P}(K_1 \subset \text{Int}V_{i_1}, \dots, K_n \subset \text{Int}V_{i_n} \text{ for some } t_{i_1} < \dots < t_{i_n} < 0).$$

Proposition 8.4.1 *Let us denote*

$$F^{(n)}(K_1, \dots, K_n) = E\nu(\text{Int}X \ominus \check{K}_1) \prod_{j=2}^n E\nu((\text{Int}X \ominus \check{K}_j) \cap (X \oplus \underline{\check{K}}_{j-1})^c), \quad (8.9)$$

and

$$G^{(n)}(K_1, \dots, K_n) = \prod_{j=1}^n E\nu(X \oplus \underline{\check{K}}_j), \quad (8.10)$$

where, for all $j = 1, \dots, n$,

$$\underline{\check{K}}_j = \bigcup_{k=1}^j K_k. \quad (8.11)$$

Then

$$Q^{(n)}(K_1, \dots, K_n) = \frac{F^{(n)}(K_1, \dots, K_n)}{G^{(n)}(K_1, \dots, K_n)}. \quad (8.12)$$

Remark 8.4.2 Note that (C-2) implies $E\nu(X) > 0$ and thus that $G^{(n)}(K_1, \dots, K_n)$ does not vanish for non-empty compact sets.

Proof. Within this proof section, we fix n non-empty compact sets K_1, \dots, K_n and we write $Q^{(n)}$ for $Q^{(n)}(K_1, \dots, K_n)$. Summing over disjoint events we have that

$$Q^{(n)} = \mathbb{E} \left(\sum \mathbb{1}(t_{i_1} < \dots < t_{i_n} < 0) \prod_{j=1}^n \mathbb{1}(K_j \subset \text{Int}V_{i_j}) \right), \quad (8.13)$$

where the sum is taken over all n -tuples of points in Φ . First note that only n -tuples of distinct points may be considered in this sum and that, from the definition of visible parts in (8.5) and (C-3), the summand in this equation may be written as

$$\mathbb{1}(t_{i_1} < \dots < t_{i_n} < 0) \prod_{j=1}^n \mathbb{1}(K_j \subset (x_{i_j} + \text{Int}X_{i_j})) \prod_{t_i > t_{i_j}} \mathbb{1}(K_j \cap (x_i + X_i) = \emptyset). \quad (8.14)$$

In the simplest case $n = 1$, this amounts to say that $Q^{(1)}$ is the probability that there exists a leaf X_i such that K_1 is included in $\text{Int}X_i$ and is not hit by subsequent leaves. We will now apply the Campbell Formula to compute this expectation, and therefore need the following notation. Let $\mathcal{E} := \mathbb{R}^2 \times (-\infty, 0] \times \mathcal{F}$. We write $\mathcal{N}^{(n)}$ (\mathcal{N} for $n = 1$) for the space of σ -finite counting measures on \mathcal{E}^n . For all $n \geq 1$, we define the point process on \mathcal{E}^n , $\Phi^{(n)} = \sum_{i_1, \dots, i_n} \delta_{z_{i_1}, \dots, z_{i_n}}$, where the sum is taken over all indices (i_1, \dots, i_n) such that z_{i_1}, \dots, z_{i_n} are distinct points of Φ . We define a function f from $\mathcal{E}^n \times \mathcal{N}^{(n)}$ to \mathbb{R} so that (8.14) reads $f(\{z_{i_j}\}_{j=1}^n, \Phi^{(n)})$. Applying the refined Campbell Theorem (see [55]) to compute the expectation in (8.13), we get

$$Q^{(n)} = \int_{Z \in \mathcal{E}^n} \int_{\phi \in \mathcal{N}^{(n)}} f(Z, \phi) \mathbb{P}^Z(d\phi) \prod_{j=1}^n \mu_\Phi(d\tilde{z}_j),$$

where $Z = \{\tilde{z}_j\}_{j=1}^n$, μ_Φ is the intensity measure of Φ and \mathbb{P}^Z is the Palm distribution of the process $\Phi^{(n)}$ at Z . Applying the generalized Slivnyak Theorem (see [102] and in Appendix §B.3) gives

$$Q^{(n)} = \int_{Z \in \mathcal{E}^n} \mathbb{E} \left[f(Z, (\Phi + \delta_{\tilde{z}_1} + \dots + \delta_{\tilde{z}_n})^{(n)}) \right] \prod_{j=1}^n \mu_\Phi(d\tilde{z}_j), \quad (8.15)$$

where, as usual, \mathbb{E} is the expectation associated to Φ . Writing $\tilde{z}_j = (\tilde{x}_j, \tilde{t}_j, \tilde{X}_j)$ for $j = 1, \dots, n$, with $\tilde{t}_1 < \dots < \tilde{t}_n < 0$, by definition of f , we have

$$\begin{aligned} f(Z, (\Phi + \delta_{\tilde{z}_1} + \dots + \delta_{\tilde{z}_n})^{(n)}) &= f(Z, \Phi^{(n)}) = \\ &= \left(\prod_{j=1}^n \mathbb{1}(K_j \subset \tilde{x}_j + \text{Int}\tilde{X}_j) \right) \left(\prod_{j=2}^n \mathbb{1}(\underline{K}_{j-1} \cap (\tilde{x}_j + \tilde{X}_j) = \emptyset) \right) \\ &= \left(\prod_{j=1}^{n-1} \prod_{t_i \in (\tilde{t}_j, \tilde{t}_{j+1}]} \mathbb{1}(\underline{K}_j \cap (x_i + X_i) = \emptyset) \right) \prod_{t_k \in (\tilde{t}_n, 0]} \mathbb{1}(\underline{K}_n \cap (x_k + X_k) = \emptyset), \end{aligned} \quad (8.16)$$

with \underline{K}_j as defined in (8.11). The expectation in (8.15) is computed as follows. Since Φ is a Poisson process, the last line of (8.16) can be written as a product of independent terms whose expectations can be computed using that, at fixed $s < t \leq 0$, and for K compact,

$$\mathbb{P}(K \cap (x_i + X_i) = \emptyset \text{ for all } t_i \in (s, t]) = \exp((s-t)E\nu(X \oplus \check{K}))$$

(see Lemma 8.3.4). Next, integrating with respect to $\mathbb{1}(\tilde{t}_1 < \dots < \tilde{t}_n < 0)d\tilde{t}_1 \dots d\tilde{t}_n$ and using a change of variable $u_j = \tilde{t}_j - \tilde{t}_{j+1}$, for $j = 1, \dots, n-1$, we obtain

$$Q^{(n)} = \prod_{j=1}^n E\nu(X \oplus \underline{K}_j)^{-1} \int_{(\mathbb{R}^2 \times \mathcal{F})^n} \left(\prod_{j=1}^n \mathbb{1}(K_j \subset \tilde{x}_j + \text{Int}\tilde{X}_j) \right) \left(\prod_{j=2}^n \mathbb{1}(\underline{K}_{j-1} \cap (\tilde{x}_j + \tilde{X}_j) = \emptyset) \right) \prod_{j=1}^n (d\tilde{x}_j P(d\tilde{X}_j)).$$

The first term of the right-hand side of the previous equation is $(G^{(n)})^{-1}$, and the term of the second line writes

$$\prod_{j=1}^n \left(\int_{\mathbb{R}^2 \times \mathcal{F}} \mathbb{1}(K_j \subset \tilde{x} + \text{Int}\tilde{X}) \mathbb{1}(\underline{K}_{j-1} \cap (\tilde{x} + \tilde{X}) = \emptyset) d\tilde{x} P(d\tilde{X}) \right),$$

with the convention $\underline{K}_0 = \emptyset$. Now, for two compact sets A and B , we have

$$\int \mathbb{1}(A \subset (x + \text{Int}X)) \mathbb{1}(B \cap (x + X) = \emptyset) \nu(dx) P(dX) = E\nu((\text{Int}X \ominus \check{A}) \cap (X \oplus \check{B})^c),$$

which, along with the last equations, yields $F^{(n)}$ and then (8.12). \square

For $n = 1$, we get the original result of Matheron, (8.8), and the case $n = 2$ was treated in [96]. Note that from the $Q^{(n)}$'s, we can compute the probability

$$\mathbb{P}(K_1 \subset \text{Int}V_{i_1}, \dots, K_n \subset \text{Int}V_{i_n} \text{ for some } i_1, \dots, i_n \in \mathbb{N})$$

and thus the probability for n connected compact sets K_1, \dots, K_n to avoid the boundary of the dead leaves tessellation. For $n = 2$ for instance, this is

$$\mathbb{P}((K_1 \cup K_2) \cap \partial M = \emptyset) = Q^{(2)}(K_1, K_2) + Q^{(2)}(K_2, K_1) + Q^{(1)}(K_1 \cup K_2).$$

Moreover, it is easily seen that if we consider the random field obtained by independently coloring each visible part, then Proposition 8.4.1 enables to compute the finite dimensional distributions of this field. This is a useful result in the context of image modeling, see [79]. Next, we show that the knowledge of $Q^{(n)}$ for all n characterizes the distribution of ∂M in $(\mathcal{F}, \mathcal{B}_{\mathcal{F}})$.

Proposition 8.4.3 *The distribution of the boundary ∂M is uniquely determined by the functionals $Q^{(n)}$, $n \in \mathbb{N}$.*

Proof. The distribution of ∂M is characterized by its capacity functional defined for every compact set K by $\mathbb{P}(F \cap K = \emptyset)$, see [119]. Let $K \in \mathcal{K}$, let $r_n > 0$ be a sequence converging to 0, and for each n , let $\{x_i^{(n)}\}_{i=1, \dots, N_n}$ be finite sequences in K such that $K \subset C_n = \cup_i B(x_i^{(n)}, r_n)$, where $B(x, r)$ is the (closed) ball centered at x with radius r . Note that since each C_n is a finite union of connected compact sets, the knowledge of the $Q^{(i)}$, $i \in \mathbb{N}$, uniquely determines $\mathbb{P}(C_n \cap \partial M = \emptyset)$. Now since $C_n \downarrow K$, we have that $\mathcal{F}^{C_n} \uparrow \mathcal{F}^K$, and thus that $\mathbb{P}(C_n \cap \partial M = \emptyset) \uparrow \mathbb{P}(K \cap \partial M = \emptyset)$. \square

8.4.2 Typical relief cells

In this section, we take interest in the distribution of cells that remain completely visible. This problem was first addressed in [118], see also [117], [143] and [95].

Definition 8.4.4 *A cell V_i is a relief cell if $(x_i + X_i) = V_i$. Denote by $N_r = \sum_i \mathbb{1}(V_i = (x_i + X_i))\delta_{x_i, V_i}$ the point process of relief cells.*

As in the proof of Proposition 8.3.2, one can show that N_r is stationary and mixing. From Condition (C-3) if $V_i = (x_i + X_i)$ then $\text{Int}V_i \neq \emptyset$. It follows that N_r is a thinning of N and since N has finite intensity, so has N_r .

Proposition 8.4.5 *The typical relief cell distribution is absolutely continuous with respect to P with Radon-Nikodym derivative $F \mapsto (\mu_r E\nu(\text{Int}X \oplus \check{F}))^{-1}$, where $\mu_r := \int_{\mathcal{F}} \frac{P(dF)}{E\nu(\text{Int}X \oplus \check{F})}$ is the intensity of N_r .*

Remark 8.4.6 As a consequence of this Proposition, the typical relief cell distribution and the leaf distribution P are equivalent measures on \mathcal{I} . This remark completes the proof of the “only if” part of Proposition 8.3.8.

Proof. N_r is a simple point process with finite intensity. We denote by $\mathbb{P}_{N_r}^0$ the Palm distribution of N_r . Writing $N_r = \sum \delta_{x_i^r, V_i^r}$, we have, for all $\chi \in \mathcal{I}$,

$$\begin{aligned} \mathbb{P}_{N_r}^0(V_0^r \in \chi) &= \frac{1}{\mu_r} \mathbb{E} \sum_i \mathbb{1}(V_i^r \in \chi) \mathbb{1}(x_i^r \in [0, 1]^2) \\ &= \frac{1}{\mu_r} \mathbb{E} \sum_i \mathbb{1}(V_i \in \chi, x_i \in [0, 1]^2, (x_i + X_i) \cap \bigcup_{t_j \in (t_i, 0]} (x_j + \text{Int}X_j) = \emptyset). \end{aligned}$$

From Slivnyak’s theorem and Campbell’s formula,

$$\begin{aligned} \mathbb{P}_{N_r}^0(V_0^r \in \chi) &= \frac{1}{\mu_r} \int_{\mathbb{R}^2 \times \mathbb{R}_- \times \chi} \mathbb{P}((x + F) \cap \bigcup_{t_j \in (t, 0]} (x_j + \text{Int}X_j) = \emptyset) \nu(dx) dt P(dF) \\ &= \frac{1}{\mu_r} \int_{\mathbb{R}_- \times \chi} \exp(t E\nu(\text{Int}X \oplus \check{F})) dt P(dF) \\ &= \frac{1}{\mu_r} \int_{\chi} [E\nu(\text{Int}X \oplus \check{F})]^{-1} P(dF), \end{aligned}$$

where the second equality follows from Lemma 8.3.4. Taking $\chi = \mathcal{F}'$, we also find the announced formula for the intensity. \square

For example, we can compute the area distribution of a typical relief cell. For $\chi_s = \{F \in \mathcal{F}' : \nu(F) > s\}$, we find $\mathbb{E}_{N_r}^0(\nu(X_0^r)) = \mu_r^{-1} \int_{\mathcal{F}'} \nu(F) [E\nu(\text{Int}X \oplus \check{F})]^{-1} P(dF)$.

Remark 8.4.7 For $d = 2$, if X is convex and isotropic a.s., we obtain the original result of Matheron by applying the Steiner Formula to compute μ_r . Let $l(K)$ denote the length of ∂K , for K convex, we have $\mu_r = E \left[(\nu(X) + \frac{2}{\pi} l(X) E l(X) + E\nu(X))^{-1} \right]$.

8.4.3 Cells intersected with a line

We now take interest in the intersection between the dead leaves model and a fixed line D . In this section we take $d \geq 2$ and, in addition to (C-1)-(C-3), we assume that

(C-4) $\nu(\partial X) = 0$ a.s. and, for any line D' , $D' \cap \partial X$ is either empty, finite or has positive $\nu_{D'}$ measure a.s.,

where $\nu_{D'}$ is the one-dimensional Lebesgue measure on D' . This assumption is for instance verified if X is a finite union of convex sets, a.s.

We will compute the Palm distribution of the point process $\partial M \cap D$ and, in the case where X is convex, prove a result from [118] in the Palm calculus framework.

Lemma 8.4.8 *$\partial M \cap D$ is a point process on D .*

Proof. Since ∂M is a locally finite union of sets ∂V_i s a.s. and since, for all i , ∂V_i is included in a finite union of sets $(x_j + \partial X_j)$, it is sufficient to show, that, a.s., for any j , $(x_j + \partial X_j) \cap D$ is a finite or empty set. Let us suppose that this does not hold. By (C-4), it implies that with positive probability, there exists j such that $\nu_D(x_j + \partial X_j) > 0$. Thus $\mathbb{E}\nu_D\{\cup_j(x_j + \partial X_j)\} > 0$. Without loss of generality, we let D be the first coordinate axis. By Fubini's theorem and translation invariance, we obtain

$$\mathbb{E}\nu\left\{\bigcup_j(x_j + \partial X_j)\right\} = \int_{\mathbf{y} \in \mathbb{R}^{d-1}} \mathbb{E}\nu_{D_{\mathbf{y}}}\left\{\bigcup_j(x_j + \partial X_j)\right\} d\mathbf{y} > 0,$$

where, for any $\mathbf{y} = (y_2, \dots, y_d)$, $D_{\mathbf{y}}$ is the line parallel to D going through the point $(0, y_2, \dots, y_d)$. Thus, a.s., there exists j such that $\mathbb{E}\nu(\partial X_j) > 0$, which is in contradiction with (C-4). \square

We let \mathbf{u} be a unit vector colinear to D , denote by $[0, x\mathbf{u}]$ the segment $\{\lambda x\mathbf{u}, \lambda \in [0, 1]\}$ and define, for all $x \geq 0$,

$$L(x) = \mathbb{P}([0, x\mathbf{u}] \subset \text{Int}V_i \text{ for some } i \in \mathbb{N}) = Q^{(1)}([0, x\mathbf{u}]) = \frac{E\nu(\text{Int}X \ominus [0, -x\mathbf{u}])}{E\nu(X \oplus [0, -x\mathbf{u}])}, \quad (8.17)$$

where $Q^{(1)}$ is defined above in Section 8.4.1 and the last equality follows from (8.8).

From now on we denote by $N_\ell = \sum_i \delta_{y_i}$ the simple point process defined in Lemma 8.4.8, with points in \mathbb{R} , write \mathbb{P}_{N_ℓ} for its law and $\mathbb{P}_{N_\ell}^0$ for its associated Palm distribution. We index N_ℓ such that $\{y_i\}$ is increasing and $y_0 < 0 < y_1$. The following lemma links the Palm distribution of N_ℓ to L .

Lemma 8.4.9 *Let $N_\ell = \sum_i \delta_{y_i}$ be the simple stationary point process defined above. Then $L(x)$ is absolutely continuous, has a negative right derivative $L'(0)$ at $x = 0$ and, almost everywhere,*

$$\mathbb{P}_{N_\ell}^0(y_1 > x) = \frac{L'(x)}{L'(0)}. \quad (8.18)$$

Proof. Observe that $L(x) = \mathbb{P}_{N_\ell}(y_1 > x)$ for all non-negative x . Let λ be the intensity of N_ℓ . The inversion formula (see for example [20]) gives, for all $x \geq 0$,

$$L(x) = \mathbb{P}_{N_\ell}(y_1 > x) = \lambda \int_x^\infty \mathbb{P}_{N_\ell}^0(y_1 > t) dt.$$

By derivating we obtain that $L'(x) = -\lambda \mathbb{P}_{N_\ell}^0(y_1 > x)$. Observing that $\mathbb{P}_{N_\ell}^0(y_1 = 0) = 0$, we obtain the differentiability of L at the origin and $L'(0) = -\lambda < 0$. \square

We end this section by considering the case of an a.s. convex X . First, we introduce the *geometric covariogram* γ_X of X , defined for $x \geq 0$ by

$$\gamma_X(x) := \nu(X \cap (x\mathbf{u} \oplus X)).$$

Note that the covariogram is usually defined on \mathbb{R}^d , but that here we only take interest in a half-line. Let $p_{\mathbf{u}^\perp}$ denote the orthogonal projection on the hyperplane orthogonal to \mathbf{u} and $\nu_{\mathbf{u}^\perp}$ denote the $(d-1)$ -dimensional Lebesgue measure on this hyperplane. If X is convex, then γ_X is a convex function on $[0, W_{\mathbf{u}})$, where $W_{\mathbf{u}}$ is the width of X in direction \mathbf{u} , and is identically zero outside this interval. Moreover, it is continuously differentiable on $[0, W_{\mathbf{u}})$ with derivative $\gamma'_X(x) = -\nu_{\mathbf{u}^\perp}[p_{\mathbf{u}^\perp}(X \cap (x\mathbf{u} \oplus X))] \geq -\nu_{\mathbf{u}^\perp}(p_{\mathbf{u}^\perp}(X))$, see [119]. From (C-1) and (C-2), we have $E\nu_{\mathbf{u}^\perp}(p_{\mathbf{u}^\perp}(X)) < \infty$. Hence, $E\gamma_X$ is absolutely continuous with derivative $E(\gamma'_X(x))$ almost everywhere; from now on we simply write $E\gamma'_X(x)$ for $E(\gamma'_X(x))$. Moreover $\gamma'_X(x)$ is right continuous at $x = 0$ and so is $E\gamma'_X(x)$ by dominated convergence, so that $E\gamma_X(x)$ has the right-hand derivative $E\gamma'_X(0) = -E\nu_{\mathbf{u}^\perp}(p_{\mathbf{u}^\perp}(X))$ at $x = 0$.

Definition 8.4.10 *The intercept distribution (in the direction \mathbf{u}) of X is defined as*

$$F_X(x) = \frac{E\gamma'_X(x)}{E\gamma'_X(0)}, \quad x \geq 0. \quad (8.19)$$

Remark 8.4.11 The term intercept distribution refers to the fact that $\gamma'_X(x)/\gamma'_X(0)$ is the probability distribution of the length of the intersection of X with lines having direction \mathbf{u} uniformly distributed among those hitting X , see [143].

Proposition 8.4.12 *Let M be a dead leaves model associated to a RACS X which is convex with intercept distribution F_X a.s. and let $\mathbb{P}_{N_\ell}^0$ and y_1 be defined as above. Then, for all $x \geq 0$,*

$$\int_x^\infty \mathbb{P}_{N_\ell}^0(y_1 > t) dt = \frac{1}{2}(1 + Kx)^{-1} \int_x^{+\infty} F_X(t) dt, \quad (8.20)$$

where $K = -E\gamma'_X(0)/E\gamma_X(0)$.

Proof. It can be shown that, when X is convex, $\nu(X \ominus [0, -x\mathbf{u}]) = \gamma_X(x)$ and $\nu(X \oplus [0, -x\mathbf{u}]) = \gamma_X(0) + x\nu_{\mathbf{u}^\perp}(p_{\mathbf{u}^\perp}(X))$. Since $\nu_{\mathbf{u}^\perp}(p_{\mathbf{u}^\perp}(X)) = -E\gamma'_X(0)$, Relation (8.17) yields

$$L(x) = \frac{E\gamma_X(x)}{E\gamma_X(0) - xE\gamma'_X(0)},$$

and the result then follows from (8.18) and (8.19) through easy calculations. \square

Let us finally notice that $\mathbb{P}_{N_\ell}^0(y_1 > x)$ may be seen (as in section 8.2.2) as the length distribution of the ‘‘typical cell’’ of the tessellation $D \cap M := \sum_i \mathbb{1}\{V_i \cap D \neq \emptyset\} \delta_{V_i \cap D}$, and thus as the intercept distribution of the typical cell of M (which is not convex). Notice also that by taking $x = 0$ in formula (8.20), we obtain

$$\mathbb{E}_{N_\ell}^0(y_1) = \frac{1}{2} \int_0^{+\infty} F_X(t) dt,$$

which says (see Remark 8.4.11) that, for a convex X , the mean intercept in any direction is divided by two as a result of occlusion.

Chapter 9

Monte Carlo methods for sensitivity analysis of Poisson-driven stochastic systems

Résumé Nous donnons des méthodes de Monte Carlo pour estimer la sensibilité de certaines fonctionnelles de Processus de Poisson. Nous appliquons nos résultats à des systèmes stochastiques qui ont un intérêt en probabilité géométrique, en files d'attente et dans les assurances.

Abstract We give Monte Carlo methods to estimate the sensitivity of suitable functionals of independently marked Poisson processes. We apply our results to stochastic systems which are of interest in geometric probability, in queueing and insurance.

9.1 Introduction

Sensitivity (or perturbation) analysis is concerned with evaluating derivatives, with respect to parameters of interest, of performance measures of discrete-event systems. There are several motivations for being interested in such a question: the main reasons are the applications to optimization and control of complex systems occurring, for instance, in queueing and insurance. The concept of sensitivity analysis was introduced by Ho and Cao [91], and has been addressed by many authors (see, for instance, the book by Glassermann [74] and the references cited therein). There are mainly three ways to handle this problem: the infinitesimal perturbation analysis (IPA), the likelihood ratio method (LRM), and the rare perturbation analysis (RPA). We refer the reader to L'Ecuyer [111] and Suri and Zazanis [148] for more insight into the IPA method, and to Reimann and Weiss [137] for more details on the LRM. It is worthwhile to mention the work by Decreusefond [56] where, using Malliavin calculus, it is shown that IPA, RPA and LRM can be seen as a part of the stochastic calculus of variations.

In this chapter we focus on sensitivity analysis of suitable functionals of Poisson processes using the RPA method. The functionals we consider are of interest in view of applications geometric probability, in queueing and in insurance. Let N^λ be an independently marked Poisson process (IMPP) with intensity $\lambda > 0$, $\phi(N^\lambda)$ a suitable functional (see Subsection 9.2.2) of the whole trajectory, and suppose we wish to compute the derivative $\frac{d}{d\lambda}E[\phi(N^\lambda)]$. We distinguish two different RPA methods: the virtual and the phantom. The virtual RPA method may be attributed to Reiman and Simon [136], and has been revisited by Baccelli and Brémaud [19]. Following the ideas of these articles we propose a Monte Carlo algorithm to compute the derivative. Basically, under suitable assumptions, we evaluate the limit

$$\lim_{\Delta\lambda \rightarrow 0} \frac{E[\phi(N^{\lambda+\Delta\lambda}) - \phi(N^\lambda)]}{\Delta\lambda}.$$

The key idea is to use the superposition property of Poisson processes to generate $N^{\lambda+\Delta\lambda}$: by a coupling argument the process $N^{\lambda+\Delta\lambda}$ is generated from a small perturbation of N^λ . The phantom RPA method was introduced by Brémaud and Vazquez-Abad [45]. Following the ideas of these authors, we propose an alternative Monte Carlo algorithm to compute the derivative. Basically, under suitable conditions, we compute the limit

$$\lim_{\Delta\lambda \rightarrow 0} \frac{E[\phi(N^\lambda) - \phi(N^{\lambda-\Delta\lambda})]}{\Delta\lambda}.$$

The key idea is to use the thinning property of Poisson processes to generate $N^{\lambda-\Delta\lambda}$: similarly to the previous case, the process $N^{\lambda-\Delta\lambda}$ is generated from a small perturbation of N^λ by a coupling argument. We also give Monte Carlo methods to compute the n^{th} order derivatives $\frac{d^n}{d\lambda^n}E[\phi(N^\lambda)]$.

As an example we examine the sensitivity of functionals stabilizing some geometric graph. Moreover, by using importance sampling and large deviations techniques, we show that these results can be applied to estimate the sensitivity of stochastic systems described in terms of Poisson shot noise processes (for instance, the simple teletraffic model of Example 1, introduced by Kostantopoulos and Lin [109], and studied also by Klüppelberg, Mikosch and Schärff [107]). Similarly, Monte Carlo estimators for the derivatives, with respect to the intensity rate of the arrival process, of the tail probability of the stationary waiting time in a $M/GI/1$ queue can be obtained. In this case we are able to find asymptotically optimal Monte Carlo estimators for the first order derivative.

The chapter is organized as follows. In Section 2 we fix notations and we give some preliminaries about analyticity and differentiability of functionals of Poisson processes. We present our results in Section 3. In Section 4 we apply our results to stochastic systems driven by Poisson shot noise and compound Poisson processes. A numerical illustration is given in Section 5.

9.2 Preliminaries

9.2.1 Some notations

Let $d \in \mathbb{N}$, $d \geq 1$ and $B(x, r)$ denote the open ball of center x and radius r in \mathbb{R}^d . O is a point in \mathbb{R}^d taken as the origin. π_d will denote the d -dimensional Lebesgue measure of the unit ball in \mathbb{R}^d and $|\cdot|$ the euclidian norm.

Let M be a complete separable metric space and \mathcal{N} the space of all counting measures on $\mathbb{R}^d \times M$, defined on the Borel σ -field $\mathcal{B}(\mathbb{R}^d) \otimes \mathcal{B}(M)$. In this chapter we assume that each measure in \mathcal{N} is locally finite that is it is finite on each set of the form $A \times K$, where A is a bounded Borel set, and $K \in \mathcal{B}(M)$. We endow the space \mathcal{N} with its usual topology (see, for instance, the book by Daley and Vere-Jones [55] for the details). A (locally finite) marked point process on \mathbb{R}^d with marks in M is a measurable mapping $N : \Omega \rightarrow \mathcal{N}$ defined on some probability space (Ω, \mathcal{F}, P) . Any point process on \mathbb{R}^d with marks in M can be represented as

$$N = \sum_{n \in \mathbb{Z}} \delta_{(T_n, Z_n)},$$

where $\delta_{(t,z)}$, $(t, z) \in \mathbb{R}^d \times M$, is the Dirac measure on $\mathcal{B}(\mathbb{R}^d) \otimes \mathcal{B}(M)$, that is for any $A \in \mathcal{B}(\mathbb{R}^d)$, $K \in \mathcal{B}(M)$, $\delta_{(t,z)}(A \times K) = 1$ if $(t, z) \in A \times K$ and 0 otherwise. Here $\{T_n\}_{n \in \mathbb{Z}}$ is a sequence of $\overline{\mathbb{R}^d}$ -valued random variables (where $\overline{\mathbb{R}^d} = \mathbb{R}^d \cup \{\pm\infty\}$) such that if $|T_n| < \infty$, then $T_n < T_{n+1}$, and $\{Z_n\}_{n \in \mathbb{Z}}$ is a sequence of M -valued random marks. Throughout this work, we denote the set of points of N in $B(O, t) \times M$ by $N_{|t}$, the number of points of N in $B(O, t) \times M$ by N_t , and by \mathcal{F}_t^N the σ -field

$$\mathcal{F}_t^N = \sigma\{N(C \times D) : C \in \mathcal{B}(\mathbb{R}^d), C \subseteq B(O, t), D \in \mathcal{B}(M)\}, \quad t \geq 0.$$

Moreover, if T is an \mathcal{F}_t^N -stopping time we set

$$\mathcal{F}_T^N = \sigma\{F \in \mathcal{F} : F \cap \{T \leq t\} \in \mathcal{F}_t^N, t \geq 0\}.$$

Let $N' = \{(T'_n, Z'_n)\}_{n \in \mathbb{Z}}$ be a marked point process on \mathbb{R}^d with marks in M . As usual in the context of point processes, we set

$$\int_{\mathbb{R}^d \times M} \psi(N', t, z) N(dt \times dz) = \sum_{n \in \mathbb{Z}} \psi(N', T_n, Z_n) \delta_{T_n}(\mathbb{R}^d),$$

for any measurable functional $\psi : \mathcal{N} \times \mathbb{R}^d \times M \rightarrow \mathbb{R}^d$ such that the sum is well defined.

As already mentioned in the Introduction, throughout this chapter we denote by N^λ an IMPP of intensity $\lambda > 0$: that is the ground process $\{T_n\}_{n \in \mathbb{Z}}$ is a homogeneous Poisson process with intensity λ , the random marks $\{Z_n\}_{n \in \mathbb{Z}}$ are independent and identically distributed (i.i.d. for short), and the sequences $\{T_n\}_{n \in \mathbb{Z}}$ and $\{Z_n\}_{n \in \mathbb{Z}}$ are independent. Finally, we recall that N^λ is actually a Poisson point process on $\mathbb{R}^d \times M$ with intensity measure $\lambda dt \times Q(dz)$, where Q is the common distribution of the marks.

9.2.2 Analyticity and differentiability of functionals of Poisson processes

Our analysis is based on a result, due to Zazanis [164], concerning the analyticity of functionals of Poisson processes, which we briefly recall. Let ϕ be a measurable functional from \mathcal{N} to \mathbb{R} , $f(\lambda) = E[\phi(N^\lambda)]$, $\lambda > 0$, $[a, b)$ an interval of the positive half-line, and consider the following conditions:

$$\text{For any } \lambda > 0, \text{ there exists an } \mathcal{F}_t^{N^\lambda}\text{-stopping time } T^\lambda \text{ such that} \quad (9.1)$$

$\phi(N^\lambda)$ is $\mathcal{F}_{T^\lambda}^{N^\lambda}$ -measurable.

$$\text{For any } \lambda \in [a, b] \text{ } E[|\phi(N^\lambda)|^\gamma] < \infty \text{ for some } \gamma > 1. \quad (9.2)$$

$$\text{For any } \lambda \in [a, b], \text{ there exists } s = s(\lambda) > 0 \text{ such that} \quad (9.3)$$

$$E[\exp(s(T^\lambda)^d)] < \infty.$$

It holds

Theorem 9.2.1 *Assume (9.1), (9.2), and (9.3), then $f(\lambda)$ is analytic on $[a, b]$.*

It is worthwhile to mention that in its paper Zazanis considers the stronger assumptions:

(i) For any $\lambda \in [a, b]$ $E[\phi^4(N^\lambda)] < \infty$.

(ii) $d = 1$.

Assumption (i) is in place of (9.2), however the differentiability of f holds under the weaker hypothesis (9.2), as can be easily realized by a right use of Hölder inequality in the proof of Lemma 2 of [164].

Assumption (ii) seems to be more limitative. As it can be realized from Section 2 in Zazanis [164], what matters in Zazanis's proof is that the function $\lambda \mapsto E[\phi(N^\lambda)]$ is a mapping from \mathbb{R}_+ to \mathbb{R} . Then the only small differences are contained in Equation (1) and the statement of Lemma 1. Equation (1) should be replaced by:

$$\frac{dP_{\lambda, T}}{dP_{a, T}} = \left(\frac{\lambda}{a}\right)^{N_T} \exp(-\pi_d T^d (\lambda - a)).$$

Lemma 1 need also some light modification. We will prove an analog lemma (see Lemma 9.3.4).

An important result on the differentiability of $f(\lambda)$ in a neighborhood of the origin is given by Baccelli, Hausenfuss and Schmidt [22] (see Theorems 2 and 3 therein). The main differences between the work by Zazanis and that one of Baccelli et al. are the following. In their paper Baccelli et al. give sufficient conditions (different from those one in the work by Zazanis) for the m -differentiability of $f(\lambda)$ on $[0, b]$, and they give an explicit expression for the m -th order derivatives. However, their condition on the existence of uniform coupling times is too strong for our purposes. This is the main reason for which we have chosen the approach of Zazanis. It is worthwhile to remark that in this chapter we computed the m -th order derivatives under a set of assumptions which differs from that one in Baccelli et al., and we give Monte Carlo estimators to compute these derivatives by simulation.

Throughout this chapter we refer to the following definition of monotonicity for functionals of marked point processes. In the following the symbol $\text{supp}(\mu)$ denotes the support of the counting measure $\mu \in \mathcal{N}$, i.e. if $\mu = \sum_{n \in \mathbb{Z}} \delta_{(t_n, z_n)}$, $\text{supp}(\mu) = \{(t_n, z_n)\}_{n \in \mathbb{Z}}$.

Definition 9.2.2 *Let ϕ be a measurable functional from \mathcal{N} to \mathbb{R} , N a locally finite marked point process on \mathbb{R}^d with marks in M , and T an \mathcal{F}_t^N -stopping time such that $\phi(N)$ is \mathcal{F}_T^N -measurable. We say that the couple (ϕ, T) is nonincreasing (nondecreasing) if, for all $\mu, \mu' \in \mathcal{N}$, $\text{supp}(\mu) \subseteq \text{supp}(\mu')$ implies $T(\mu) \geq T(\mu')$ ($T(\mu) \leq T(\mu')$). The couple (ϕ, T) is said monotone if it is nonincreasing or nondecreasing.*

We give a couple of examples as a guide to intuition. Assume $d = 1$ and for $\mu \in \mathcal{N}$, define the functional $\phi(\mu) = 1 \wedge t_1$, being t_1 the first (unmarked) point of μ on $(0, \infty)$. Let N be a marked point process on $\mathbb{R} \times M$ and define $T = T_1$, being T_1 the first (unmarked) point of N on $(0, \infty)$. Then it can be easily checked that (ϕ, T) is nonincreasing but it is not nondecreasing. Now define $T = 1$, then (ϕ, T) is nonincreasing and nondecreasing.

9.3 Rare perturbation analysis

9.3.1 Rare Perturbation Analysis of monotone functionals: the first order derivative

In this subsection we compute the first order derivative of f in the case of monotone functionals. The following Theorem 9.3.1 holds.

Theorem 9.3.1 *Under assumptions of Theorem 9.2.1, if moreover the couple (ϕ, T^λ) is monotone then, for all $\lambda \in [a, b)$,*

$$\begin{aligned} f'(\lambda) &= \pi_d E[(T^\lambda)^d (\phi(N^\lambda + \delta_{(\tau, \widehat{Z})}) - \phi(N^\lambda))] = E \left[\frac{N_{T^\lambda}^\lambda}{\lambda} (\phi(N^\lambda) - \phi(N^\lambda - \delta_{(\tau', Z')})) \right] \\ &= E \left[\frac{1}{\lambda} \int_{B(O, T^\lambda) \times M} (\phi(N^\lambda) - \phi(N^\lambda - \delta_{(t, z)})) N^\lambda (dt \times dz) \right], \end{aligned} \quad (9.4)$$

Here, given T^λ , τ is a random variable uniformly distributed on $B(O, T^\lambda)$, and independent of N^λ ; \widehat{Z} has law Q and it is independent of N^λ and τ ; given the collection of points $N_{|T^\lambda}^\lambda$, (τ', Z') is a random variable uniformly distributed on the collection.

To prove this theorem we need two preliminary propositions:

Proposition 9.3.2 *Under assumptions of Theorem 9.2.1, if moreover the couple (ϕ, T^λ) is nonincreasing then, for all $\lambda \in [a, b)$,*

$$f'(\lambda) = \pi_d E[(T^\lambda)^d (\phi(N^\lambda + \delta_{(\tau, \widehat{Z})}) - \phi(N^\lambda))], \quad (9.5)$$

where τ and \widehat{Z} are defined in Theorem 9.3.1.

Proposition 9.3.3 *Under assumptions of Theorem 9.2.1, if moreover the couple (ϕ, T^λ) is nondecreasing then, for all $\lambda \in [a, b)$,*

$$\begin{aligned} f'(\lambda) &= E \left[\frac{N_{T^\lambda}^\lambda}{\lambda} (\phi(N^\lambda) - \phi(N^\lambda - \delta_{(\tau', Z')})) \right] \\ &= E \left[\frac{1}{\lambda} \int_{B(O, T^\lambda) \times M} (\phi(N^\lambda) - \phi(N^\lambda - \delta_{(t, z)})) N^\lambda (dt \times dz) \right], \end{aligned} \quad (9.6)$$

where (τ', Z') is defined in Theorem 9.3.1.

To prove these propositions we need in turn the following lemmas:

Lemma 9.3.4 *Under assumptions (9.1) and (9.3), for all $\lambda \in [a, b)$, there exists $s' = s'(\lambda) > 0$ such that $E[\exp(s' N_{T^\lambda}^\lambda)] < \infty$.*

Lemma 9.3.5 *Under assumptions of Theorem 9.2.1, for all $\alpha \in [0, \gamma)$, the function $\lambda \mapsto E[|\phi(N^\lambda)|^\alpha]$ is analytic on $[a, b)$, and therefore continuous.*

We start showing Lemma 9.3.4.

Proof. Let s be given by assumption (9.3), and set $C = E[\exp(s(T^\lambda)^d)]$ and $\delta > e^2 \pi_d \lambda$. We notice that

$$P(N_{T^\lambda}^\lambda > k) \leq P((T^\lambda)^d > k/\delta) + P(N_{(k/\delta)^{1/d}}^\lambda > k), \quad \text{for all } k \geq 0. \quad (9.7)$$

By the usual inequality for the Poisson distribution (see, for instance, the book by Penrose [129], Lemma 1.2) we have

$$P(N_{(k/\delta)^{1/d}}^\lambda > k) \leq \exp\left(-\frac{k}{2} \log\left(\frac{\delta}{\pi_d \lambda}\right)\right), \quad \text{for all } k \geq 0. \quad (9.8)$$

Therefore, by (9.7), (9.8) and Markov inequality, it follows that, for all $k \geq 0$,

$$P(N_{T^\lambda}^\lambda > k) \leq C \exp\left(-\frac{s}{\delta} k\right) + \exp\left(-\frac{k}{2} \log\left(\frac{\delta}{\pi_d \lambda}\right)\right).$$

Finally, we easily deduce that, for $0 < s' < \min\{s/\delta, \frac{1}{2} \log(\delta/\pi_d \lambda)\}$, $E[\exp(s' N_{T^\lambda}^\lambda)] = 1 + (e^{s'} - 1) \sum_{k \geq 0} \exp(s' k) P(N_{T^\lambda}^\lambda > k) < \infty$. \square

We now prove Lemma 9.3.5.

Proof. The conclusion is trivial for $\alpha = 0$. Assume $\alpha > 0$ and define, for $\mu \in \mathcal{N}$, the functional $\Phi(\mu) = |\phi(\mu)|^\alpha$. The corresponding assumptions (9.1) and (9.3) are trivially satisfied. Furthermore, using Hölder inequality for $\beta = \gamma/\alpha > 1$ we get

$$E[|\Phi(N)|^\beta]^{1/\beta} = E[|\phi(N)|^\gamma]^{\alpha/\gamma} < \infty,$$

where as usual $N = N^\lambda$. The conclusion follows by Theorem 9.2.1. \square

We now prove Proposition 9.3.2. For this we use the so-called virtual Rare Perturbation method considered in [19] (see also Vazquez-Abad [157]).

Proof. To render the notation more easy we set $N = N^\lambda$ and $T = T^\lambda$. A straightforward computation gives

$$\begin{aligned} E[|\phi(N + \delta_{(\tau, \hat{Z})}) - \phi(N)| | N] &= \frac{1}{\pi_d T^d} \int_{B(O, T) \times M} |\phi(N + \delta_{(t, z)}) - \phi(N)| dt Q(dz) \\ &= \frac{1}{\pi_d T^d} \int_{\mathbb{R}^d \times M} |\phi(N + \delta_{(t, z)}) - \phi(N)| dt Q(dz), \quad \text{a.s.}, \end{aligned} \quad (9.9)$$

where the latter equality follows by condition (9.1). Indeed, by the \mathcal{F}_T^N -measurability of $\phi(N)$ follows the $\mathcal{F}_T^{N+\delta_{(t, z)}}$ -measurability of $\phi(N + \delta_{(t, z)})$ for each (t, z) , and therefore $\phi(N + \delta_{(t, z)}) = \phi(N)$ for any $t \in \mathbb{R}^d$ with $|t| > T$. Thus the integrability of the random variable $T(\phi(N + \delta_{(\tau, \hat{Z})}) - \phi(N))$ follows by Lemma 9.3.9 which we state and prove later on in this chapter. Let $N' = \sum_{n \in \mathbb{Z}} \delta_{(T'_n, Z'_n)}$ be an IMPP with intensity $\Delta\lambda$, such that Z'_1 has law Q and N' is independent of N . By an elementary property of Poisson processes, $N + N'$ is an IMPP with intensity $\lambda + \Delta\lambda$. Here we choose $\Delta\lambda$ small enough so that $\lambda + \Delta\lambda < b$. Consider the $\mathcal{F}_t^{N+N'}$ -stopping time $T^{\lambda+\Delta\lambda} = T'$ given by condition (9.1). By the monotonicity assumption on (ϕ, T) we have that $T' \leq T$ a.s.. Thus $\phi(N + N')$ is also $\mathcal{F}_T^{N+N'}$ -measurable, and therefore

$$\phi(N) = \phi(N|_T) \quad \text{and} \quad \phi(N + N') = \phi((N + N')|_T). \quad (9.10)$$

We notice that

$$\begin{aligned} \frac{f(\lambda + \Delta\lambda) - f(\lambda)}{\Delta\lambda} &= E[\phi(N + N') - \phi(N)]/\Delta\lambda \\ &= \frac{1}{\Delta\lambda} E \left[\sum_{k \geq 1} \mathbf{1}(N'_T = k) (\phi(N + N') - \phi(N)) \right] \\ &= \frac{1}{\Delta\lambda} E[\mathbf{1}(N'_T = 1) (\phi(N + N') - \phi(N))] \end{aligned} \quad (9.11)$$

$$+ \frac{1}{\Delta\lambda} E[\mathbf{1}(N'_T \geq 2) (\phi(N + N') - \phi(N))], \quad (9.12)$$

where the second equality follows noticing that on $\{N'_T = 0\}$ by (9.10) we have $\phi(N) = \phi(N + N')$. Fix $\alpha \in (1, \gamma)$, by Lemma 9.3.5 the function $\lambda \rightarrow E[|\phi(N)|^\alpha]$ is continuous on $[a, b]$. Therefore there exists a positive constant $C > 0$ such that $E[|\phi(N)|^\alpha] < C^\alpha$ and $E[|\phi(N + N')|^\alpha] < C^\alpha$. Using Hölder and Minkowski inequalities we have

$$\begin{aligned} \left| E[\mathbf{1}(N'_T \geq 2)(\phi(N + N') - \phi(N))] \right| &\leq \left(P(N'_T \geq 2) \right)^{1-1/\alpha} \left(E[|\phi(N + N') - \phi(N)|^\alpha] \right)^{1/\alpha} \\ &\leq 2C \left(E \left[\sum_{k \geq 2} \frac{(\Delta\lambda)^k \pi_d^k T^{dk}}{k!} e^{-\Delta\lambda\pi_d T^d} \right] \right)^{1-1/\alpha} \\ &\leq 2C(\pi_d \Delta\lambda)^{2(1-1/\alpha)} (E[T^{2d}])^{1-1/\alpha}. \end{aligned} \quad (9.13)$$

By assumption (9.3) we have $E[T^{2d}] < \infty$. Therefore, by inequality (9.13) it follows that the term in (9.12) goes to zero, as $\Delta\lambda \rightarrow 0$. Since N' is independent of N it follows

$$\begin{aligned} E[\mathbf{1}(N'_T = 1)(\phi(N + N') - \phi(N))] &= E[E[\mathbf{1}(N'_T = 1)(\phi(N + N') - \phi(N)) | N]] \\ &= E[\Delta\lambda\pi_d T^d e^{-\Delta\lambda\pi_d T^d} E[(\phi(N + N') - \phi(N)) | N, N'_T = 1]] \\ &= E[\Delta\lambda\pi_d T^d e^{-\Delta\lambda\pi_d T^d} E[(\phi(N + \delta_{(\tau, \widehat{Z})}) - \phi(N)) | N]] \\ &= \pi_d \Delta\lambda E[T^d e^{-\Delta\lambda\pi_d T^d} (\phi(N + \delta_{(\tau, \widehat{Z})}) - \phi(N))]. \end{aligned} \quad (9.14)$$

Thus by the dominated convergence theorem the term in (9.11) converges to $\pi_d E[T^d (\phi(N + \delta_{(\tau, \widehat{Z})}) - \phi(N))]$, as $\Delta\lambda \rightarrow 0$. \square

We now prove Proposition 9.3.3. For this we use the so-called phantom Rare Perturbation method introduced in [45] (see also [157]).

Proof. Set $N = N^\lambda$ and $T = T^\lambda$. By condition (9.1) we have $\phi(N - \delta_{(T^*, Z^*)}) = \phi(N)$ a.s., for all $T^* \notin B(O, T)$ and therefore

$$\int_{B(O, T) \times M} |\phi(N) - \phi(N - \delta_{(t, z)})| N(dt \times dz) = \int_{\mathbb{R}^d \times M} |\phi(N) - \phi(N - \delta_{(t, z)})| N(dt \times dz). \quad (9.15)$$

Thus the integrability of the random variable $\int_{(0, T] \times M} (\phi(N) - \phi(N - \delta_{(t, z)})) N(dt \times dz)$ follows by Lemma 9.3.10 which we state and prove later on in this chapter. Let $\{\beta_n\}_{n \in \mathbb{Z}}$ be an i.i.d. sequence of Bernoulli random variables defined by $P(\beta_n = 0) = 1 - P(\beta_n = 1) = \Delta\lambda/\lambda$ and independent of N . Consider the thinned IMPP of intensity $\lambda - \Delta\lambda$ given by $\tilde{N} = \tilde{N}^{\lambda - \Delta\lambda} = \sum_{n \in \mathbb{Z}} \beta_n \delta_{(T_n, Z_n)}$. By condition (9.1) and the monotonicity assumption on (ϕ, T) it follows that $\phi(N)$ and $\phi(\tilde{N})$ are \mathcal{F}_T^N -measurable. The equality in (9.6) is given by the following computations:

$$\begin{aligned} E \left[\frac{N_T}{\lambda} (\phi(N) - \phi(N - \delta_{(\tau', Z')})) \right] &= E \left[E \left[\frac{N_T}{\lambda} (\phi(N) - \phi(N - \delta_{(\tau', Z')})) \mid N_T \right] \right] \\ &= E \left[\frac{1}{\lambda} \int_{B(O, T) \times M} (\phi(N) - \phi(N - \delta_{(t, z)})) N(dt \times dz) \right]. \end{aligned}$$

We finally show

$$f'(\lambda) = E \left[\frac{1}{\lambda} \int_{B(O, T) \times M} (\phi(N) - \phi(N - \delta_{(t, z)})) N(dt \times dz) \right]. \quad (9.16)$$

By the independence of $\{\beta_n\}_{n \in \mathbb{Z}}$ and N we have, for $0 \leq k \leq N_T$,

$$P(N_T - \tilde{N}_T = k | N) = \binom{N_T}{k} \left(\frac{\Delta\lambda}{\lambda} \right)^k \left(1 - \frac{\Delta\lambda}{\lambda} \right)^{N_T - k}.$$

This equation implies

$$E[\mathbf{1}(N_T - \tilde{N}_T = k)(\phi(N) - \phi(\tilde{N}))] = E \left[\binom{N_T}{k} \left(\frac{\Delta\lambda}{\lambda} \right)^k \left(1 - \frac{\Delta\lambda}{\lambda} \right)^{N_T - k} E[\phi(N) - \phi(\tilde{N}) | N, N_T - \tilde{N}_T = k] \right].$$

By the \mathcal{F}_T^N -measurability of $\phi(N)$ and $\phi(\tilde{N})$ we have $E[\mathbf{1}(N_T - \tilde{N}_T = 0)(\phi(N) - \phi(\tilde{N}))] = 0$. Therefore

$$\begin{aligned} (f(\lambda) - f(\lambda - \Delta\lambda))/\Delta\lambda &= \frac{E[\phi(N) - \phi(\tilde{N})]}{\Delta\lambda} \\ &= \frac{1}{\Delta\lambda} E \left[\sum_{k \geq 1} \mathbf{1}(N_T - \tilde{N}_T = k)(\phi(N) - \phi(\tilde{N})) \right] \\ &= \frac{1}{\Delta\lambda} E \left[N_T \left(\frac{\Delta\lambda}{\lambda} \right) \left(1 - \frac{\Delta\lambda}{\lambda} \right)^{N_T - 1} E[\phi(N) - \phi(\tilde{N}) | N, N_T - \tilde{N}_T = 1] \right] \end{aligned} \quad (9.17)$$

$$+ \frac{1}{\Delta\lambda} E \left[\mathbf{1}(N_T - \tilde{N}_T \geq 2)(\phi(N) - \phi(\tilde{N})) \right]. \quad (9.18)$$

We notice that, given N , the random variable $\phi(\tilde{N}) | \{N_T - \tilde{N}_T = 1\}$ has the same law of $\phi(N - \delta_{(t', z')})$. Thus, using obvious notations,

$$E[\phi(N) - \phi(\tilde{N}) | N = \mu, N_T - \tilde{N}_T = 1] = \frac{1}{\mu_T(\mu)} \int_{B(O, T(\mu)) \times M} (\phi(\mu) - \phi(\mu - \delta_{(t, z)})) \mu(dt \times dz). \quad (9.19)$$

By the dominated convergence theorem and (9.19) it follows that, as $\Delta\lambda \rightarrow 0$, the term in (9.17) goes to

$$E \left[\frac{1}{\lambda} \int_{B(O, T) \times M} (\phi(N) - \phi(N - \delta_{(t, z)})) N(dt \times dz) \right].$$

The conclusion follows if we prove that the term in (9.18) goes to zero as $\Delta\lambda \rightarrow 0$. Fix $\alpha \in (1, \gamma)$, by Lemma 9.3.5 the function $\lambda \rightarrow E[|\phi(N)|^\alpha]$ is continuous on $[a, b]$. Therefore there exists a positive constant $C > 0$ such that $E[|\phi(N)|^\alpha] < C^\alpha$ and $E[|\phi(\tilde{N})|^\alpha] < C^\alpha$. Using Hölder and Minkowski inequalities we have

$$\begin{aligned} \left| E \left[\mathbf{1}(N_T - \tilde{N}_T \geq 2)(\phi(N) - \phi(\tilde{N})) \right] \right| &\leq \left(P(N_T - \tilde{N}_T \geq 2) \right)^{1-1/\alpha} \left(E[|\phi(N) - \phi(\tilde{N})|^\alpha] \right)^{1/\alpha} \\ &\leq 2C \left(E \left[\sum_{k=2}^{N_T} \binom{N_T}{k} \left(\frac{\Delta\lambda}{\lambda} \right)^k \left(1 - \frac{\Delta\lambda}{\lambda} \right)^{N_T - k} \right] \right)^{1-1/\alpha} \end{aligned} \quad (9.20)$$

As can be easily checked, for any $n \geq 2$ and $p \in (0, 1)$,

$$\sum_{m=2}^n \binom{n}{m} p^m (1-p)^{n-m} \leq \frac{1}{2} n^2 p^2. \quad (9.21)$$

Thus by (9.20) and (9.21) the modulus of the term in (9.18) can be bounded from above by

$$2C \left(1/2 \left(\frac{\Delta\lambda}{\lambda} \right)^2 E[N_T^2] \right)^{1-1/\alpha},$$

and this quantity goes to zero as $\Delta\lambda \rightarrow 0$, since $E[N_T^2] < \infty$ by Lemma 9.3.4. \square

We finally show Theorem 9.3.1.

Proof. For ease of notation we set again $N = N^\lambda$ and $T = T^\lambda$. Throughout this proof we assume (ϕ, T) nonincreasing. A similar argument (using first Proposition 9.3.3) can be applied in the nondecreasing case. As for (9.9) we have

$$E[\phi(N + \delta_{(\tau, \hat{Z})}) - \phi(N)|N] = \frac{1}{\pi_d T^d} \int_{\mathbb{R}^d \times M} (\phi(N + \delta_{(t, z)}) - \phi(N)) dt Q(dz), \quad a.s.. \quad (9.22)$$

By (9.22) and Proposition 9.3.2 it follows

$$f'(\lambda) = \pi_d E[T^d (\phi(N + \delta_{(\tau, \hat{Z})}) - \phi(N))] = \int_{\mathbb{R}^d} E[\phi(N + \delta_{(t, \hat{Z})}) - \phi(N)] dt. \quad (9.23)$$

Using the same argument as for (9.15) and the Slyvniak-Mecke theorem (see, for instance, Daley and Vere-Jones [55]) we get

$$\begin{aligned} E \left[\int_{B(O, T) \times M} (\phi(N) - \phi(N - \delta_{(t, z)})) N(dt \times dz) \right] &= E \left[\int_{\mathbb{R}^d \times M} (\phi(N) - \phi(N - \delta_{(t, z)})) N(dt \times dz) \right] \\ &= \lambda \int_{\mathbb{R}^d} E[\phi(N + \delta_{(t, \hat{Z})}) - \phi(N)] dt. \end{aligned} \quad (9.24)$$

The conclusion follows by equalities (9.23), (9.24), and equality (9.6), which does not depend on the monotonicity of the couple (ϕ, T) . \square

9.3.2 Higher order derivatives

In this subsection we generalize Theorem 9.3.1 giving some Monte Carlo methods to compute the n^{th} -order derivative $f^{(n)}(\lambda)$ of f at λ .

Let ϕ be a measurable functional from \mathcal{N} to \mathbb{R} . As in [136] and Blaszczyzyn [32], for $\mu \in \mathcal{N}$, $n \geq 1$ and $(t_1, z_1), \dots, (t_n, z_n) \in \mathbb{R}^d \times M$, define

$$\phi_{(t_1, z_1), \dots, (t_n, z_n)}(\mu) = \mathbf{D}(t_1, \dots, t_n) \sum_{k=0}^n (-1)^{n-k} \sum_{\pi \in \{\binom{n}{k}\}} \phi \left(\mu + \sum_{i \in \pi} \delta_{(t_i, z_i)} \right), \quad (9.25)$$

where $\mathbf{D}(t_1, \dots, t_n) = \mathbf{1}(\{t_1, \dots, t_n \text{ are distinct}\})$ and $\{\binom{n}{k}\}$ denotes the collection of all subsets with cardinality k of $\{1, \dots, n\}$. For $\mu \in \mathcal{N}$, $n \geq 1$ and $(t_1, z_1), \dots, (t_n, z_n) \in \mathbb{R}^d \times M$, define also

$$\phi^{(t_1, z_1), \dots, (t_n, z_n)}(\mu) = \mathbf{D}(t_1, \dots, t_n) \phi_{(t_1, z_1), \dots, (t_n, z_n)} \left(\mu - \sum_{i=1}^n \delta_{(t_i, z_i)} \right). \quad (9.26)$$

We notice that $\phi_{(t_1, z_1), \dots, (t_n, z_n)}(\mu)$ (and therefore $\phi^{(t_1, z_1), \dots, (t_n, z_n)}(\mu)$) is invariant by permutations in the sense that for any permutation σ of $\{1, \dots, n\}$ $\phi_{(t_{\sigma(1)}, z_{\sigma(1)}), \dots, (t_{\sigma(n)}, z_{\sigma(n)})}(\mu) = \phi_{(t_1, z_1), \dots, (t_n, z_n)}(\mu)$. Furthermore, as can be easily seen reasoning by induction on $n \geq 1$, we have for distinct t_1, \dots, t_{n+1}

$$\phi_{(t_1, z_1), \dots, (t_{n+1}, z_{n+1})}(\mu) = \phi_{(t_1, z_1), \dots, (t_n, z_n)}(\mu + \delta_{(t_{n+1}, z_{n+1})}) - \phi_{(t_1, z_1), \dots, (t_n, z_n)}(\mu) \quad (9.27)$$

and

$$\phi^{(t_1, z_1), \dots, (t_{n+1}, z_{n+1})}(\mu) = \phi^{(t_1, z_1), \dots, (t_n, z_n)}(\mu) - \phi^{(t_1, z_1), \dots, (t_n, z_n)}(\mu - \delta_{(t_{n+1}, z_{n+1})}). \quad (9.28)$$

The following Theorem 9.3.6 holds.

Theorem 9.3.6 (We use the convention that the sum over an empty set is zero and $k!/(k-n)! = 0$ for $n > k$). Under assumptions of Theorem 9.3.1, for all $\lambda \in [a, b)$ and $n \geq 1$,

$$f^{(n)}(\lambda) = \pi_d^n E[(T^\lambda)^{dn} \phi_{(\tau_1, \hat{Z}_1), \dots, (\tau_n, \hat{Z}_n)}(N^\lambda)] = E \left[\frac{(N_{T^\lambda}^\lambda)^n}{\lambda^n} \phi_{(\tau'_1, Z'_1), \dots, (\tau'_n, Z'_n)}(N^\lambda) \right] \quad (9.29)$$

$$= E \left[(1/\lambda^n) \sum_{((T_1^*, Z_1^*), \dots, (T_n^*, Z_n^*)) \in (N_{|T^\lambda}^\lambda)^{\otimes n}} \phi_{(T_1^*, Z_1^*), \dots, (T_n^*, Z_n^*)}(N^\lambda) \right] \quad (9.30)$$

$$= E \left[\frac{N_{T^\lambda}^\lambda!}{(N_{T^\lambda}^\lambda - n)! \lambda^n} \phi_{(\tau''_1, Z''_1), \dots, (\tau''_n, Z''_n)}(N^\lambda) \right]. \quad (9.31)$$

Here, given T^λ , τ_1, \dots, τ_n are independent, uniformly distributed on $B(O, T^\lambda)$, and independent of N^λ ; $\hat{Z}_1, \dots, \hat{Z}_n$ are independent with law Q , and independent of N^λ and τ_1, \dots, τ_n ; given the collection of points $N_{|T^\lambda}^\lambda$, $(\tau'_1, Z'_1), \dots, (\tau'_n, Z'_n)$ are independent and uniformly distributed on the collection, and $\{(\tau''_1, Z''_1), \dots, (\tau''_n, Z''_n)\}$ is uniformly distributed on the set of subsets of n distinct points of $N_{|T^\lambda}^\lambda$; the symbol $(N_{|T^\lambda}^\lambda)^{\otimes n}$ denotes the set of the n -tuples of n distinct points of $N_{|T^\lambda}^\lambda$.

Note that both equations (9.30) and (9.31) imply that $f^{(n)}(\lambda) = 0$ if $T^\lambda < T_n$ with probability one, being T_n the n^{th} point on $(0, \infty)$ of the Poisson process.

To prove this Theorem 9.3.6 we need the following preliminary propositions:

Proposition 9.3.7 Under assumptions of Proposition 9.3.2, for all $\lambda \in [a, b)$ and $n \geq 1$,

$$f^{(n)}(\lambda) = \pi_d^n E[(T^\lambda)^{dn} \phi_{(\tau_1, \hat{Z}_1), \dots, (\tau_n, \hat{Z}_n)}(N^\lambda)], \quad (9.32)$$

where $\tau_1, \dots, \tau_n, \hat{Z}_1, \dots, \hat{Z}_n$ are defined in Theorem 9.3.6.

Proposition 9.3.8 Under assumptions of Proposition 9.3.3, for all $\lambda \in [a, b)$ and $n \geq 1$,

$$f^{(n)}(\lambda) = E \left[\frac{(N_{T^\lambda}^\lambda)^n}{\lambda^n} \phi_{(\tau'_1, Z'_1), \dots, (\tau'_n, Z'_n)}(N^\lambda) \right] \quad (9.33)$$

$$= E \left[(1/\lambda^n) \sum_{((T_1^*, Z_1^*), \dots, (T_n^*, Z_n^*)) \in (N_{|T^\lambda}^\lambda)^{\otimes n}} \phi_{(T_1^*, Z_1^*), \dots, (T_n^*, Z_n^*)}(N^\lambda) \right], \quad (9.34)$$

where $(\tau'_1, Z'_1), \dots, (\tau'_n, Z'_n)$ and $(N_{|T^\lambda}^\lambda)^{\otimes n}$ are defined in Theorem 9.3.6.

To prove these propositions we need in turn Lemmas 9.3.9 and 9.3.10 below. For any $\mu \in \mathcal{N}$ and $n \geq 1$, define the functionals

$$\psi(\mu) = \int_{(\mathbb{R}^d \times M)^n} |\phi_{(t_1, z_1), \dots, (t_n, z_n)}(\mu)| dt_1 \dots dt_n Q(dz_1) \dots Q(dz_n) \quad (9.35)$$

and (with the convention that the sum over an empty set is zero)

$$\chi(\mu) = \sum_{\{(t_1, z_1), \dots, (t_n, z_n)\} \subset \mu} |\phi_{(t_1, z_1), \dots, (t_n, z_n)}(\mu)|, \quad (9.36)$$

where the sum is taken on sets of n distinct points of μ . It holds

Lemma 9.3.9 *Under assumptions of Theorem 9.2.1, if moreover the couple (ϕ, T^λ) is nonincreasing then, for all $\lambda \in [a, b)$ and $\alpha \in [1, \gamma)$, $E[\psi(N^\lambda)^\alpha] < \infty$ for any $\alpha \in [1, \gamma)$.*

Lemma 9.3.10 *Under assumptions of Theorem 9.2.1, if moreover the couple (ϕ, T^λ) is nondecreasing then, for all $\lambda \in [a, b)$ and $\alpha \in [1, \gamma)$, $E[\chi(N^\lambda)^\alpha] < \infty$ for any $\alpha \in [1, \gamma)$.*

We start showing Lemma 9.3.9.

Proof. For simplicity of notation set $T = T^\lambda$ and $N = N^\lambda$. Let $q > 1$ be such that $q\alpha \leq \gamma$ and $p > 1$ such that $1/p + 1/q = 1$. Moreover, let N' be the IMPP defined in the proof of Proposition 9.3.2 with $\Delta\lambda$ chosen so that $\lambda + \Delta\lambda < b$ and $E[\exp(2p\alpha\Delta\lambda\pi_d T^d)] < \infty$. Reasoning by induction on $n \geq 1$ it can be easily realized that condition (9.1) implies

$$\phi_{(t_1, z_1), \dots, (t_n, z_n)}(N) = 0 \quad \text{for any } (t_1, \dots, t_n) \notin B(O, T)^n, \quad (9.37)$$

and therefore

$$\psi(N) = \int_{(B(O, T) \times M)^n} |\phi_{(t_1, z_1), \dots, (t_n, z_n)}(N)| dt_1 \dots dt_n Q(dz_1) \dots Q(dz_n).$$

It follows

$$\begin{aligned} \psi(N) &\leq \pi_d^n T^{dn} \sum_{k=0}^n \binom{n}{k} (\pi_d T^d)^{-k} \int_{(B(O, T) \times M)^k} \left| \phi \left(N + \sum_{i=1}^k \delta_{(t_i, z_i)} \right) \right| dt_1 \dots dt_k Q(dz_1) \dots Q(dz_k) \\ &\leq T^{dn} \sum_{k=0}^n \binom{n}{k} E[|\phi(N + N')| | N'_T = k, N] \\ &\leq T^{dn} E[|\phi(N + N')| | N] \sum_{k=0}^n \binom{n}{k} P(N'_T = k | N)^{-1} \\ &\leq T^{dn} E[|\phi(N + N')| | N] \sum_{k=0}^n \binom{n}{k} \frac{k!}{(\Delta\lambda\pi_d T^d)^k} \exp(\Delta\lambda\pi_d T^d) \\ &= \frac{n!}{(\Delta\lambda)^n} \exp(\Delta\lambda\pi_d T^d) E[|\phi(N + N')| | N] \sum_{k=0}^n \frac{(\Delta\lambda\pi_d T^d)^{n-k}}{(n-k)!} \\ &\leq \frac{n!}{(\Delta\lambda)^n} \exp(2\Delta\lambda\pi_d T^d) E[|\phi(N + N')| | N]. \end{aligned}$$

Using Jensen and Hölder inequalities we deduce that

$$\begin{aligned} E[\psi(N)^\alpha] &\leq \left(\frac{n!}{(\Delta\lambda)^n} \right)^\alpha E[\exp(2\alpha\Delta\lambda\pi_d T^d) (E[|\phi(N + N')| | N])^\alpha] \\ &\leq \left(\frac{n!}{(\Delta\lambda)^n} \right)^\alpha E[\exp(2\alpha\Delta\lambda\pi_d T^d) E[|\phi(N + N')|^\alpha | N]] \\ &\leq \left(\frac{n!}{(\Delta\lambda)^n} \right)^\alpha E[\exp(2p\alpha\Delta\lambda\pi_d T^d)]^{1/p} E[|\phi(N + N')|^{q\alpha}]^{1/q} < \infty. \end{aligned}$$

□

We now show Lemma 9.3.10.

Proof. Set $T = T^\lambda$ and $N = N^\lambda$. Let $(N|_T)^{\otimes n}$ denote the set of the n -tuples of n distinct points of $N|_T$, and similarly $N^{\otimes n}$ the set of the n -tuples of n distinct points of N . Moreover, let $q > 1$ be such that $\alpha q \leq \gamma$, $p > 1$ such that $1/p + 1/q = 1$, \tilde{N} the IMPP defined in the proof of Proposition 9.3.3 and $s > 0$ such that $E[\exp(sN)] < \infty$ (see Lemma 9.3.4). Here we choose $\Delta\lambda$

in such a way that $2p\alpha \log(\lambda/(\lambda - \Delta\lambda)) < s$. Reasoning by induction on $n \geq 1$ it can be easily realized that condition (9.1) implies

$$\phi^{t_1, \dots, t_n}(N) = 0 \quad \text{for any } (t_1, \dots, t_n) \notin B(O, T)^n, \quad (9.38)$$

and therefore

$$\chi(N) = \sum_{\{(T_1^*, Z_1^*), \dots, (T_n^*, Z_n^*)\} \subset N} |\phi^{(T_1^*, Z_1^*), \dots, (T_n^*, Z_n^*)}(N)| \quad (9.39)$$

$$= 1/n! \sum_{((T_1^*, Z_1^*), \dots, (T_n^*, Z_n^*)) \in (N)^{\otimes n}} |\phi^{(T_1^*, Z_1^*), \dots, (T_n^*, Z_n^*)}(N)| \quad (9.40)$$

$$= 1/n! \sum_{((T_1^*, Z_1^*), \dots, (T_n^*, Z_n^*)) \in (N|_T)^{\otimes n}} |\phi^{(T_1^*, Z_1^*), \dots, (T_n^*, Z_n^*)}(N)| \quad (9.41)$$

$$= 1/n! E \left[(N_T)^n |\phi^{(\tau'_1, Z'_1), \dots, (\tau'_n, Z'_n)}(N)| | N \right], \quad (9.42)$$

where the equality in (9.40) follows from the invariance by permutations of $\phi^{t_1, \dots, t_n}(\mu)$, the equality in (9.41) follows by (9.38), and the equality in (9.42) follows by the definition of $(\tau'_1, Z'_1), \dots, (\tau'_n, Z'_n)$. If $N_T < n$, $\chi(N) = 0$, and if $N_T \geq n$, we deduce that

$$\begin{aligned} \chi(N) &\leq E \left[(N_T)^n |\phi^{(\tau'_1, Z'_1), \dots, (\tau'_n, Z'_n)}(N)| | N \right] \\ &\leq (N_T)^n E \left[\sum_{k=0}^n \sum_{\{i_1, \dots, i_k\} \in \binom{[n]}{k}} \left| \phi \left(N - \sum_{j=1}^k \delta_{(\tau'_{i_j}, Z'_{i_j})} \right) \right| | N \right] \\ &= (N_T)^n \sum_{k=0}^n \binom{n}{k} E[|\phi(\tilde{N})| | N, N_T - \tilde{N}_T = k] \\ &\leq (N_T)^n E[|\phi(\tilde{N})| | N] \sum_{k=0}^n \binom{n}{k} P(N_T - \tilde{N}_T = k | N)^{-1} \\ &= (N_T)^n E[|\phi(\tilde{N})| | N] \sum_{k=0}^n \binom{n}{k} \frac{k!(N_T - k)!}{N_T!} \left(\frac{\Delta\lambda}{\lambda} \right)^{-k} \left(1 - \frac{\Delta\lambda}{\lambda} \right)^{k-N_T} \\ &\leq K (N_T)^n \left(\frac{\lambda}{\lambda - \Delta\lambda} \right)^{N_T} E[|\phi(\tilde{N})| | N], \end{aligned} \quad (9.43)$$

where $K = \left(\frac{\lambda}{\Delta\lambda} \right)^n \sum_{k=0}^n k! \binom{n}{k}$. Finally, using Jensen, Hölder and Cauchy-Schwartz inequalities we get

$$\begin{aligned} E[\chi(N)^\alpha] &\leq K^\alpha E \left[(N_T)^{\alpha n} \left(\frac{\lambda}{\lambda - \Delta\lambda} \right)^{\alpha N_T} |\phi(\tilde{N})|^\alpha \right] \\ &\leq K^\alpha E \left[(N_T)^{p\alpha n} \left(\frac{\lambda}{\lambda - \Delta\lambda} \right)^{p\alpha N_T} \right]^{1/p} E[|\phi(\tilde{N})|^{q\alpha}]^{1/q} \\ &\leq K^\alpha E[(N_T)^{2p\alpha n}]^{1/(2p)} E \left[\left(\frac{\lambda}{\lambda - \Delta\lambda} \right)^{2p\alpha N_T} \right]^{1/(2p)} E[|\phi(\tilde{N})|^{q\alpha}]^{1/q} < \infty. \end{aligned}$$

□

We now show Proposition 9.3.7.

Proof. Set $T = T^\lambda$ and $N = N^\lambda$. Note that by (9.37) we have

$$\psi(N) = \pi_d^n E[T^{dn} |\phi_{(\tau_1, \hat{Z}_1), \dots, (\tau_n, \hat{Z}_n)}(N)| | N].$$

Thus the integrability of $T^{dn} \phi_{(\tau_1, \hat{Z}_1), \dots, (\tau_n, \hat{Z}_n)}(N)$ for any $n \geq 1$ follows by Lemma 9.3.9. We prove formula (9.32) by induction on $n \geq 1$. As already shown it holds for $n = 1$. Let $\tilde{\psi}$ be the functional defined as ψ without the modulus. By (9.1) and (9.37) it is easily seen that $\tilde{\psi}(N)$ is \mathcal{F}_T^N -measurable. The couple $(\tilde{\psi}, T)$ is nonincreasing by the monotonicity assumption on (ϕ, T) . Assume the inductive hypothesis $f^{(n)}(\lambda) = E[\tilde{\psi}(N)]$ for $n > 1$. Fix $\alpha \in (1, \gamma)$, by Lemma 9.3.9 we have $E[|\tilde{\psi}(N)|^\alpha] < \infty$ for each $\lambda \in [a, b)$. Define the random variables τ_{n+1} and \hat{Z}_{n+1} as follows: given T , τ_{n+1} is uniformly distributed on $B(O, T)$, and independent of N, τ_1, \dots, τ_n ; \hat{Z}_{n+1} has law Q and is independent of $N, \tau_1, \dots, \tau_{n+1}$ and $\hat{Z}_1, \dots, \hat{Z}_n$. By Proposition 9.3.2 we get

$$f^{(n+1)}(\lambda) = \pi_d E[T^d (\tilde{\psi}(N + \delta_{(\tau_{n+1}, \hat{Z}_{n+1})}) - \tilde{\psi}(N))].$$

The conclusion follows noticing that by (9.37) and (9.27) we have

$$\begin{aligned} \pi_d E[T^d (\tilde{\psi}(N + \delta_{(\tau_{n+1}, \hat{Z}_{n+1})}) - \tilde{\psi}(N))] &= \int_{\mathbb{R}^d \times M} E[\tilde{\psi}(N + \delta_{(t, z)}) - \tilde{\psi}(N)] dt Q(dz) \\ &= \int_{(\mathbb{R}^d \times M)^{n+1}} E[\phi_{(t_1, z_1), \dots, (t_{n+1}, z_{n+1})}(N)] dt_1 \dots dt_{n+1} \\ &\quad Q(dz_1) \dots Q(dz_{n+1}) \\ &= \pi_d^{n+1} E[T^{d(n+1)} \phi_{(\tau_1, \hat{Z}_1), \dots, (\tau_{n+1}, \hat{Z}_{n+1})}(N)]. \end{aligned}$$

□

We now prove Proposition 9.3.8.

Proof. Set $T = T^\lambda$ and $N = N^\lambda$. By (9.39)-(9.42) we get

$$E \left[\frac{(N_T)^n}{\lambda^n} |\phi_{(\tau'_1, Z'_1), \dots, (\tau'_n, Z'_n)}(N)| \mid N \right] = n! \chi(N) / \lambda^n.$$

Thus the integrability of $\frac{(N_T)^n}{\lambda^n} \phi_{(\tau'_1, Z'_1), \dots, (\tau'_n, Z'_n)}(N)$ for any $n \geq 1$ follows by Lemma 9.3.10. We prove formula (9.33) by induction on $n \geq 1$. As already shown it holds for $n = 1$. Let $\tilde{\chi}$ be the functional defined by

$$\tilde{\chi}(\mu) = \frac{n!}{\lambda^n} \sum_{\{(t_1, z_1), \dots, (t_n, z_n)\} \subset \mu} \phi^{(t_1, z_1), \dots, (t_n, z_n)}(\mu).$$

Since

$$\tilde{\chi}(N) = 1/\lambda^n \sum_{((T_1^*, Z_1^*), \dots, (T_n^*, Z_n^*)) \in (N|_T)^{\otimes n}} \phi^{(T_1^*, Z_1^*), \dots, (T_n^*, Z_n^*)}(N)$$

(see (9.39)-(9.41)) we have that $\tilde{\chi}(N)$ is \mathcal{F}_T^N -measurable. The couple $(\tilde{\chi}, T)$ is nondecreasing by the monotonicity assumption on (ϕ, T) . Since for each $n \geq 1$

$$\tilde{\chi}(N) = E \left[\frac{(N_T)^n}{\lambda^n} \phi_{(\tau'_1, Z'_1), \dots, (\tau'_n, Z'_n)}(N) \mid N \right]$$

(see (9.41)-(9.42)) the equality in (9.34) holds. Assume the inductive hypothesis $f^{(n)}(\lambda) = E[\tilde{\chi}(N)]$ for $n > 1$. Fix $\alpha \in (1, \gamma)$, by Lemma 9.3.10 we have $E[|\tilde{\chi}(N)|^\alpha] < \infty$ for each $\lambda \in [a, b)$. Let (τ'_{n+1}, Z'_{n+1}) be a random variable such that, given $N|_T$, it is independent of

$(\tau'_1, Z'_1), \dots, (\tau'_n, Z'_n)$ and uniformly distributed on the collection $N|_T$. By Proposition 9.3.3 we get

$$f^{(n+1)}(\lambda) = E \left[\frac{N_T}{\lambda} (\tilde{\chi}(N) - \tilde{\chi}(N - \delta_{(\tau'_{n+1}, Z'_{n+1})})) \right].$$

The conclusion follows noticing that by (9.28)

$$\begin{aligned} & E[\tilde{\chi}(N) - \tilde{\chi}(N - \delta_{(\tau'_{n+1}, Z'_{n+1})}) | N] = \\ & E \left[\left(\frac{N_T}{\lambda} \right)^n (\phi^{(\tau'_1, Z'_1), \dots, (\tau'_n, Z'_n)}(N) - \phi^{(\tau'_1, Z'_1), \dots, (\tau'_n, Z'_n)}(N - \delta_{(\tau'_{n+1}, Z'_{n+1})})) \mid N \right] = \\ & E \left[\left(\frac{N_T}{\lambda} \right)^n \phi^{(\tau'_1, Z'_1), \dots, (\tau'_{n+1}, Z'_{n+1})}(N) \mid N \right]. \end{aligned}$$

□

We now show Theorem 9.3.6.

Proof. As usual set $T = T^\lambda$ and $N = N^\lambda$. Throughout this proof we assume (ϕ, T) nonincreasing. A similar argument can be considered if (ϕ, T) is nondecreasing (in this case use Proposition 9.3.8 in place of Proposition 9.3.7). We first notice that the equality (9.30) holds without assuming (ϕ, T) monotone (see (9.41)-(9.42)). Let $\tilde{\psi}$ be the functional defined in the proof of Proposition 9.3.7 and $\tilde{\chi}$ the functional defined in the proof of Proposition 9.3.8. The equalities in (9.29) follow if we prove

$$E[\tilde{\psi}(N)] = E[\tilde{\chi}(N)], \quad (9.44)$$

indeed by Proposition 9.3.7 we have $f^{(n)}(\lambda) = E[\tilde{\psi}(N)]$. Equality (9.44) follows since by the extended Slyvniak-Campbell theorem (see Møller and Waagepetersen [126] or Equation (10.2) in Appendix) and the invariance by permutation of $\phi^{(t_1, z_1), \dots, (t_n, z_n)}(\mu)$ we have

$$\begin{aligned} E[\tilde{\chi}(N)] &= \frac{n!}{\lambda^n} \left[\sum_{\{(T_1^*, Z_1^*), \dots, (T_n^*, Z_n^*)\} \subset N} \phi^{(T_1^*, Z_1^*), \dots, (T_n^*, Z_n^*)}(N) \right] \\ &= \int_{(\mathbb{R}^d \times M)^n} E \left[\phi^{(t_1, z_1), \dots, (t_n, z_n)} \left(N + \sum_{i=1}^n \delta_{(t_i, z_i)} \right) \right] dt_1 \dots dt_n Q(dz_1) \dots Q(dz_n) \\ &= \int_{(\mathbb{R}^d \times M)^n} E[\phi_{(t_1, z_1), \dots, (t_n, z_n)}(N)] dt_1 \dots dt_n Q(dz_1) \dots Q(dz_n) \\ &= E[\tilde{\psi}(N)]. \end{aligned}$$

It remains to show equality (9.31). For this we notice that by the properties of the functional $\phi^{(t_1, z_1), \dots, (t_n, z_n)}$ it follows

$$\begin{aligned} \tilde{\chi}(N) &= n!/\lambda^n \sum_{\{(T_1^*, Z_1^*), \dots, (T_n^*, Z_n^*)\} \subset N|_T} \phi^{(T_1^*, Z_1^*), \dots, (T_n^*, Z_n^*)}(N) \\ &= \frac{N_T!}{\lambda^n (N_T - n)!} 1/\binom{N_T}{n} \sum_{\{(T_1^*, Z_1^*), \dots, (T_n^*, Z_n^*)\} \subset N|_T} \phi^{(T_1^*, Z_1^*), \dots, (T_n^*, Z_n^*)}(N) \\ &= \frac{N_T!}{\lambda^n (N_T - n)!} E[\phi^{(\tau'_1, Z'_1), \dots, (\tau'_n, Z'_n)}(N) | N]. \end{aligned}$$

where the latter equality follows from the invariance by permutations of (μ) . □

9.4 Applications

In this section, we apply Theorems 9.3.1 and 9.3.6 to obtain Monte Carlo estimators for the sensitivity of stable functionals in geometric probability and for suitable performance measures of Poisson shot noise and compound Poisson processes.

9.4.1 Stable functionals in geometric probability

Assumption (9.1) is closely related to the definition of stable functionals given in Chapter 1, Definition 1.2.1. Thus geometric probability is a natural field of application of Theorems 9.3.1 and 9.3.6.

As an example, we consider the dead leaves model analyzed in Chapter 8. The dead leaves tessellation is denoted by $M^\lambda = \sum_i \delta_{x_i, V_i}$, where V_i is the visible part of the leaf $x_i + X_i$ (see definition 8.3.6), and $N^\lambda = \sum_i \delta_{x_i, t_i, X_i}$ is the associated PPP of intensity λ . Let $V_{\{0\}}$ be the cell containing 0, its associated leaf is denoted by $x_{\{0\}} + X_{\{0\}}$. By Equation (8.3), the typical cell distribution is

$$P^0(V_0 \in \cdot) = 1/\mu^\lambda E \frac{\mathbf{1}(V_{\{0\}} \in \cdot)}{\nu(V_{\{0\}})},$$

where μ^λ is the intensity of M^λ and ν the usual Lebesgue measure. For all i , we define R_i as the radius of the smallest ball containing the leaf $x_i + X_i$. The sensitivity analysis of the typical cell distribution is an application of Theorems 9.3.1 and 9.3.6. Indeed, let $\phi(N^\lambda) = \mathbf{1}(V_{\{0\}} \in A)/\nu(V_{\{0\}})$ and $T = \max\{t_i, R_i^d : 0 \in (x_i + X_i) \text{ and } \text{Int}(V_i) \neq \emptyset\}$, clearly Assumption (9.1) is satisfied. Note that the couple (ϕ, T) is also nondecreasing. Then, assume for example that X is a closed ball of random radius r . By Lemma 8.3.4, Assumption (9.3) will be satisfied provided that $E \exp(sr^d) < \infty$ for some $s > 0$ (we do not give more details to this fact).

9.4.2 Poisson shot noise processes

A Poisson shot noise process with drift is a stochastic process of the form

$$S(t) = \sum_{n \geq 1} H(t - T_n, Z_n) \mathbf{1}_{(0, t]}(T_n) - ct,$$

where $\{T_n\}_{n \in \mathbb{Z}}$ are the points of a homogeneous Poisson process with intensity $\lambda > 0$, $\{Z_n\}_{n \in \mathbb{Z}}$ is a sequence of i.i.d. nonnegative random variables with distribution Q , $c > 0$ is a positive constant (drift), $H : \mathbb{R}^d \times [0, \infty) \rightarrow [0, \infty)$ is a nondecreasing continuous function such that $H(t, z) = 0$ for nonnegative times. Throughout this work we shall assume $H(\infty, z) = z$ and $P(0 < Z_1 < \infty) > 0$.

A standard performance measure associated with $S(t)$ is the level crossing probability

$$f_u(\lambda) = P\left(T_u^\lambda < \infty\right) \quad u > 0,$$

where

$$T_u^\lambda = \inf\{t \geq 0 : S(t) \geq u\},$$

and $T_u^\lambda = \infty$ if $\{\dots\} = \emptyset$. Below we give two examples of the stochastic model described above.

Example 1: A teletraffic model

(see [109] and [107])

Consider a computer network, and let the points $\{T_n\}_{n \geq 1}$ of a Poisson process with intensity $\lambda > 0$ be the times when a new ON-period of an individual source starts. If we denote by

$\{Z_n\}_{n \geq 1}$ the lengths of the ON-periods, then the number of active computers in the network at time t is

$$X(t) = \sum_{n \geq 1} \mathbf{1}_{(0, Z_n]}(t - T_n) \mathbf{1}_{(0, t]}(T_n).$$

Now, consider a single server queue with service rate $c > 0$ and traffic intensity $X(t)$, and suppose that a source sends a signal at unit rate. The corresponding workload process at time t is the positive part of

$$S(t) = \int_0^t X(s) ds - ct = \sum_{n \geq 1} \min\{t - T_n, Z_n\} \mathbf{1}_{(0, t]}(T_n) - ct.$$

When the buffer is not finite the queue length is $\sup_{t \geq 0} S(t)$, and therefore for a finite buffer with capacity $u > 0$ the overflow probability is overestimated by $f_u(\lambda)$.

Example 2: Risk processes with delayed claims

(see Klüppelberg and Mikosch [106, 105], and Brémaud [44])

The interpretation of the process $S(t)$ in the insurance context is the following. Suppose that claims occur according to a homogeneous Poisson process $\{T_n\}_{n \geq 1}$ with intensity $\lambda > 0$, and the insurance company honors a claim happened at time T_n at the rate $h(\cdot - T_n, Z_n)$. Then the total amount paid in the time interval $(0, t]$ is

$$\sum_{n \geq 1} H(t - T_n, Z_n) \mathbf{1}_{(0, t]}(T_n),$$

where $H(t, z) = \int_0^t h(s, z) dz$. If we assume that the insurance company has an initial capital $u > 0$, and we denote by $c > 0$ the gross premium risk, the corresponding ruin probability coincides with the performance measure $f_u(\lambda)$.

9.4.3 Sensitivity analysis of stochastic systems described by Poisson shot noise processes

By using large deviations techniques in [44] it is proved that under the following assumptions:

$$\kappa(\theta) = E[e^{\theta Z_1}] < \infty \quad \text{for all } \theta \text{ in a neighborhood of } 0, \text{ say } (0, \eta) \quad (9.45)$$

$$c > \lambda E[Z_1], \quad (9.46)$$

and

$$\text{there exists } w > 0 \text{ such that } \lambda(\kappa(w) - 1) - cw = 0 \quad (9.47)$$

it holds

$$f_u(\lambda) \leq e^{-wu}, \quad \text{for all } u \geq 0 \quad (9.48)$$

and

$$\lim_{u \rightarrow \infty} \frac{1}{u} \log f_u(\lambda) = -w. \quad (9.49)$$

Thus, under (9.45), (9.46), and (9.47) the performance measure $f_u(\lambda)$ goes to zero not slower than an exponential rate. This yields problems if we want to estimate $f_u(\lambda)$ by an efficient Monte Carlo simulation. Indeed, consider the crude Monte Carlo estimator $\frac{1}{n} \sum_{k=1}^n \mathbf{1}\{s_u^{(k)} < \infty\}$ of $f_u(\lambda)$, where $s_u^{(1)}, \dots, s_u^{(n)}$ are n independent simulations of T_u^λ under the original law P . To keep fixed the relative error

$$\frac{1}{f_u(\lambda)} \left(\frac{f_u(\lambda)(1 - f_u(\lambda))}{n} \right)^{1/2},$$

n has to grow exponentially with u . Moreover, since $f_u(\lambda) < 1$ for any $u > 0$, the simulation time can be infinity. In Torrisi [153] we have overcome these difficulties by using importance sampling. The idea is to consider independent simulations of T_u^λ under another suitable law.

Let $\{\mathcal{F}_t\}_{t \geq 0}$ denote a filtration such that, for any θ for which $\kappa(\theta) < \infty$, the process $\frac{e^{\theta C(t)}}{E[e^{\theta C(t)}]}$ is an \mathcal{F}_t -martingale, being

$$C(t) = \sum_{n \geq 1} Z_n \mathbf{1}_{(0,t]}(T_n).$$

Consider the family of laws $\{P_\theta\}_{\theta: \kappa(\theta) < \infty}$ defined as follows: the probability measure P_θ is absolutely continuous with respect to the original law P on the σ -field \mathcal{F}_t , for each $t > 0$, and the corresponding density is

$$\ell_t^{P_\theta, P} = \frac{e^{\theta C(t)}}{E[e^{\theta C(t)}]} = \exp\{\theta C(t) - \lambda t(\kappa(\theta) - 1)\}. \quad (9.50)$$

We point out (see, for instance, Brémaud [43]) that, under P_θ , the process $\{T_n\}_{n \geq 1}$ is a homogeneous Poisson process with intensity $\lambda \kappa(\theta)$, independent of the sequence $\{Z_n\}_{n \geq 1}$ of i.i.d. random variables, whose common law $P_\theta^{(Z)}$ is absolutely continuous with respect to their common law Q , with density

$$\frac{dP_\theta^{(Z)}}{dQ}(z) = \frac{e^{\theta z}}{\kappa(\theta)}.$$

The following result is proved in [153], and gives a family of laws admissible for simulations, i. e. a family of laws under which the simulation time is finite.

Proposition 9.4.1 *Under assumptions (9.45), (9.46), (9.47), if moreover*

$$\lambda E[Z_1 e^{\hat{\theta} Z_1}] - c > 0 \quad \text{for some } \hat{\theta} \in (0, \eta), \quad (9.51)$$

then $P_{\hat{\theta}}$ is an admissible law for simulations, that is $P_{\hat{\theta}}(T_u^\lambda < \infty) = 1$, for all $u > 0$.

The importance sampling estimator of $f_u(\lambda)$ is the unbiased estimator defined by

$$\frac{1}{n} \sum_{k=1}^n \ell_{t_u^{(k)}}^{P, P_{\hat{\theta}}},$$

where $t_u^{(1)}, \dots, t_u^{(n)}$ are n independent simulations of T_u^λ under $P_{\hat{\theta}}$.

In Theorem 9.4.2 below we combine the importance sampling technique and formulas in Theorem 9.3.1 to obtain Monte Carlo estimators for the sensitivity $\frac{d}{d\lambda} f_u(\lambda)$. Let N^λ denote the IMPP which defines $S(t)$, and consider, for each (locally finite) counting measure $\mu = \sum_{n \in \mathbb{Z}} \delta_{(t_n, z_n)}$ on $\mathbb{R}^d \times (0, \infty)$ and θ such that $\kappa(\theta) < \infty$, the functionals

$$\phi_\theta(\mu) = \exp \left\{ -\theta \sum_{n \in \mathbb{Z}} z_n \mathbf{1}_{(0, T_u^\lambda(\mu)]}(t_n) + \lambda T_u^\lambda(\mu)(\kappa(\theta) - 1) \right\}, \quad (9.52)$$

where the notation $T_u^\lambda(\mu)$ means that the hitting time is computed on the points of μ . It holds

Theorem 9.4.2 *Assume (9.45), (9.46), (9.47), and (9.51) for some $\hat{\theta} \leq w$. Moreover, suppose that the function $\theta \rightarrow \kappa(\theta)$, $\theta \in (0, \eta)$ is steep, namely $\lim_{n \rightarrow \infty} E[Z_1 e^{\theta_n Z_1}] = \infty$ whenever $\{\theta_n\}$ is a sequence converging to η . Then, for all $u > 0$,*

$$\begin{aligned} \frac{df_u(\lambda)}{d\lambda} &= E_{\hat{\theta}}[T_u^\lambda(\phi_{\hat{\theta}}(N^\lambda + \delta_{(\tau, \hat{z})}) - \phi_{\hat{\theta}}(N^\lambda))] = E_{\hat{\theta}} \left[\frac{N_{T_u^\lambda}^\lambda}{\lambda} (\phi_{\hat{\theta}}(N^\lambda) - \phi_{\hat{\theta}}(N^\lambda - \delta_{(\tau', z')})) \right] \\ &= E_{\hat{\theta}} \left[\frac{1}{\lambda} \int_{(0, T_u^\lambda] \times (0, \infty)} (\phi_{\hat{\theta}}(N^\lambda) - \phi_{\hat{\theta}}(N^\lambda - \delta_{(t, z)})) N^\lambda(dt \times dz) \right], \end{aligned}$$

where, $E_{\hat{\theta}}$ denotes the expectation under $P_{\hat{\theta}}$; given T_u^λ , τ is a random variable uniformly distributed on $[0, T_u^\lambda]$, and independent of N^λ ; \hat{Z} has law $P_{\hat{\theta}}^{(Z)}$, and it is independent of N^λ and τ ; given the collection of points $N_{|T_u^\lambda}^\lambda$, (τ', Z') is a random variable uniformly distributed on the collection.

Since $S(t)$ has continuous paths, then T_u^λ is an $\mathcal{F}_t^{N^\lambda}$ -stopping time. By the exponential change of measure we get, for all $u > 0$,

$$\begin{aligned} f_u(\lambda) &= E[\mathbf{1}(T_u^\lambda < \infty)] = E_{\hat{\theta}}[\exp\{-\hat{\theta}C(T_u^\lambda) + \lambda T_u^\lambda(\kappa(\hat{\theta}) - 1)\}] \\ &= E_{\hat{\theta}}[\phi_{\hat{\theta}}(N^\lambda)], \end{aligned}$$

where $\phi_{\hat{\theta}}$ is defined by (9.52). One can easily realized that assumption (9.1) is satisfied, and that the couple $(\phi_{\hat{\theta}}, T_u^\lambda)$ is nonincreasing. Thus, Theorem 9.4.2 follows by Theorem 9.3.1 if we show that $\phi_{\hat{\theta}}$ is a bounded functional, and the corresponding condition (9.3) holds. We start proving the boundedness of $\phi_{\hat{\theta}}$.

Lemma 9.4.3 *Assume (9.45), (9.46), and (9.47). If moreover (9.51) is verified for some $\hat{\theta} \leq w$, then $\phi_{\hat{\theta}}(\mu) \leq e^{-\hat{\theta}u}$ for all (locally finite) counting measures μ on $\mathbb{R}^d \times (0, \infty)$ and $u > 0$.*

Proof. The function $\theta \rightarrow \lambda(\kappa(\theta) - 1) - c\theta$ vanishes at 0, goes to $+\infty$ as $\theta \rightarrow +\infty$, and is strictly negative in a right neighborhood of 0 (indeed, it has a strictly negative first derivative in 0). By the intermediate values theorem there exists a positive $\theta^* \in (0, \eta)$ such that

$$\lambda(\kappa(\theta^*) - 1) - c\theta^* = 0.$$

Since the function $(0, \eta) \ni \theta \rightarrow \lambda(\kappa(\theta) - 1) - c\theta$ is convex, $\theta^* = w$ is unique. Thus, since $\hat{\theta} \leq w$, it holds

$$\lambda(\kappa(\hat{\theta}) - 1) - c\hat{\theta} \leq 0. \quad (9.53)$$

A straightforward computation gives, for all counting measures $\mu = \sum_{n \in \mathbb{Z}} \delta_{(t_n, z_n)}$ on $\mathbb{R}^d \times (0, \infty)$,

$$\begin{aligned} \phi_{\hat{\theta}}(\mu) &= \exp \left\{ -\hat{\theta} \sum_{n \in \mathbb{Z}} z_n \mathbf{1}_{(0, T_u^\lambda(\mu)]}(t_n) + \lambda T_u^\lambda(\mu)(\kappa(\hat{\theta}) - 1) \right\} \\ &\leq \exp \left\{ -\hat{\theta} \left(\sum_{n \in \mathbb{Z}} H(T_u^\lambda(\mu) - t_n, z_n) \mathbf{1}_{(0, T_u^\lambda(\mu)]}(t_n) - cT_u^\lambda(\mu) \right) + T_u^\lambda(\mu)[\lambda(\kappa(\hat{\theta}) - 1) - c\hat{\theta}] \right\} \\ &= \exp\{-\hat{\theta}u + T_u^\lambda(\mu)[\lambda(\kappa(\hat{\theta}) - 1) - c\hat{\theta}]\} \leq e^{-\hat{\theta}u}, \end{aligned} \quad (9.54)$$

where in (9.54) the equality follows by the definition of T_u^λ , and the inequality by (9.53). \square

To check the corresponding condition (9.3) we need the following Proposition 9.4.4, which is proved in Macci, Stabile and Torrisi [116] (see Proposition 3.1 therein). Here we consider the notion of large deviations principle, for which we refer the reader to the book by Dembo and Zeitouni [57].

Proposition 9.4.4 *Assume (9.45) and the function $\kappa(\cdot)$ steep. Then the stochastic process $\left(\frac{S(t)}{t}\right)_{t \geq 0}$ satisfies a large deviations principle with rate function $\Lambda^*(x) = \sup_{\theta \in \mathbb{R}}(\theta x - \Lambda(\theta))$, where $\Lambda(\theta) = \lambda(\kappa(\theta) - 1) - c\theta$, that is, for any Borel set B ,*

$$\begin{aligned} - \inf_{x \in B^\circ} \Lambda^*(x) &\leq \liminf_{t \rightarrow \infty} \frac{1}{t} \log P \left(\frac{S(t)}{t} \in B \right) \\ &\leq \limsup_{t \rightarrow \infty} \frac{1}{t} \log P \left(\frac{S(t)}{t} \in B \right) \leq - \inf_{x \in \bar{B}} \Lambda^*(x), \end{aligned}$$

being B° and \bar{B} the interior and the closure of B , respectively.

Lemma 9.4.5 *Under assumptions of Proposition 9.4.4, if moreover (9.51) holds, then there exists a neighborhood $[a, b)$ of λ , with $a > 0$, such that, for all $\lambda' \in [a, b)$, there exists $s' = s'(\lambda) > 0$ such that $E_{\hat{\theta}}[\exp(s'T_u^{\lambda'})] < \infty$.*

Proof. By assumption (9.51) there exists a neighborhood $[a, b)$ of λ , with $a > 0$, such that, for all $\lambda' \in [a, b)$,

$$\lambda' E[Z_1 e^{\hat{\theta} Z_1}] - c > 0.$$

Set $\hat{\kappa}(\theta) = E_{\hat{\theta}}[e^{\theta Z_1}]$. Since

$$\hat{\kappa}(\theta) = \frac{1}{\kappa(\hat{\theta})} E[e^{(\theta + \hat{\theta}) Z_1}],$$

by our assumptions it follows that $\hat{\kappa}(\theta) < \infty$ on the right neighborhood of 0 $(0, \eta - \hat{\theta})$, and that $\hat{\kappa}(\cdot)$ is steep. Let $S'(t)$ be the Poisson shot noise process with drift, and ground Poisson process of intensity λ' . By Proposition 9.4.4 the stochastic process $\left(\frac{S'(t)}{t}\right)_{t \geq 0}$ satisfies a large deviations principle with respect to $P_{\hat{\theta}}$ with rate function $\hat{\Lambda}^*(x) = \sup_{\theta \in \mathbb{R}} (\theta x - \hat{\Lambda}(\theta))$, where $\hat{\Lambda}(\theta) = \lambda' \kappa(\hat{\theta})(\hat{\kappa}(\theta) - 1) - c\theta$. Since $P(0 < Z_1 < \infty) > 0$ we have $E[Z_1 e^{\hat{\theta} Z_1}] > 0$. Thus we can choose $\alpha \in (0, E[Z_1 e^{\hat{\theta} Z_1}])$ such that $\gamma = \lambda' \alpha - c > 0$. By the large deviations principle of $\left(\frac{S'(t)}{t}\right)_{t \geq 0}$ with respect to $P_{\hat{\theta}}$, and the properties of the rate function $\hat{\Lambda}^*$ we have

$$\lim_{t \rightarrow \infty} \frac{1}{t} \log P_{\hat{\theta}} \left(\frac{S'(t)}{t} < \gamma \right) = -\hat{\Lambda}^*(\gamma). \quad (9.55)$$

By (9.55) it follows that for any $\varepsilon > 0$ there exists $\bar{t}_1 = \bar{t}_1(\varepsilon)$ such that

$$P_{\hat{\theta}} \left(\frac{S'(t)}{t} < \gamma \right) < e^{-(\hat{\Lambda}^*(\gamma) - \varepsilon)t}, \quad \text{for all } t \geq \bar{t}_1. \quad (9.56)$$

Moreover, for any $u > 0$ there exists $\bar{t}_2 = \bar{t}_2(u)$ such that

$$P_{\hat{\theta}}(T_u^{\lambda'} > t) \leq P_{\hat{\theta}}(S'(t) < u) \leq P_{\hat{\theta}} \left(\frac{S'(t)}{t} < \gamma \right), \quad \text{for all } t \geq \bar{t}_2. \quad (9.57)$$

Therefore, by (9.56) and (9.57), for any $\varepsilon, u > 0$ there exists $\bar{t} = \bar{t}(\varepsilon, u)$ such that

$$P_{\hat{\theta}}(T_u^{\lambda'} > t) < e^{-(\hat{\Lambda}^*(\gamma) - \varepsilon)t}, \quad \text{for all } t \geq \bar{t}. \quad (9.58)$$

Now, let $0 < s' < \hat{\Lambda}^*(\gamma) - \varepsilon$. The conclusion follows noticing that by (9.58) for any $\varepsilon, u > 0$ there exists $\bar{t} = \bar{t}(\varepsilon, u)$ such that

$$\begin{aligned} E_{\hat{\theta}}[\exp(s'T_u^{\lambda'})] &= 1 + s' \int_0^{\infty} e^{s't} P_{\hat{\theta}}(T_u^{\lambda'} > t) dt \\ &\leq 1 + s' \bar{t} e^{s' \bar{t}} + s' \int_{\bar{t}}^{\infty} e^{-[(\hat{\Lambda}^*(\gamma) - \varepsilon) - s']t} dt < \infty. \end{aligned}$$

□

The following generalization of Theorem 9.4.2 follows by applying Theorem 9.3.6. Let $\phi_{\theta(t_1, z_1), \dots, (t_n, z_n)}$ and $\phi_{\theta}^{(t_1, z_1), \dots, (t_n, z_n)}$ be defined, respectively, as in (9.25) and (9.26) with ϕ_{θ} (defined in (9.52)) in place of ϕ and $M = (0, \infty)$. It holds

Theorem 9.4.6 (We use the same convention of Theorem 9.3.6). Under assumptions of Theorem 9.4.2, for all $u > 0$ and $n \geq 1$, we have

$$\begin{aligned} \frac{d^n f_u(\lambda)}{d\lambda^n} &= E_{\hat{\theta}}[(T_u^\lambda)^n \phi_{\hat{\theta}}(\tau_1, \hat{Z}_1), \dots, (\tau_n, \hat{Z}_n)(N^\lambda)] = E_{\hat{\theta}} \left[\frac{(N_{T_u^\lambda}^\lambda)^n}{\lambda^n} \phi_{\hat{\theta}}^{(\tau'_1, Z'_1), \dots, (\tau'_n, Z'_n)}(N^\lambda) \right] \\ &= E_{\hat{\theta}} \left[(1/\lambda^n) \sum_{((T_1^*, Z_1^*), \dots, (T_n^*, Z_n^*)) \in (N_{|T_u^\lambda}^\lambda)^{\otimes n}} \phi_{\hat{\theta}}^{(T_1^*, Z_1^*), \dots, (T_n^*, Z_n^*)}(N^\lambda) \right]. \\ &= E_{\hat{\theta}} \left[\frac{N_{T_u^\lambda}^\lambda!}{(N_{T_u^\lambda}^\lambda - n)! \lambda^n} \phi_{\hat{\theta}}^{(\tau''_1, Z''_1), \dots, (\tau''_n, Z''_n)}(N^\lambda) \right]. \end{aligned}$$

Here, given T_u^λ , τ_1, \dots, τ_n are independent, uniformly distributed on $[0, T_u^\lambda]$, and independent of N^λ ; $\hat{Z}_1, \dots, \hat{Z}_n$ are independent with law $P_{\hat{\theta}}^{(Z)}$, and independent of N^λ and τ_1, \dots, τ_n ; given the collection of points $N_{|T_u^\lambda}^\lambda$, $(\tau'_1, Z'_1), \dots, (\tau'_n, Z'_n)$ are independent and uniformly distributed on the collection, and $\{(\tau''_1, Z''_1), \dots, (\tau''_n, Z''_n)\}$ is uniformly distributed on the set of subsets of n distinct points of $N_{|T_u^\lambda}^\lambda$; the symbol $(N_{|T_u^\lambda}^\lambda)^{\otimes n}$ denotes the set of the n -tuples of n distinct points of $N_{|T_u^\lambda}^\lambda$.

9.4.4 Compound Poisson processes

A compound Poisson process with drift is a stochastic process of the form

$$K(t) = \sum_{n \geq 1} Z_n \mathbf{1}_{(0, t]}(T_n) - ct,$$

where $\{T_n\}_{n \in \mathbb{Z}}$ are the points of a homogeneous Poisson process with intensity $\lambda > 0$, $\{Z_n\}_{n \in \mathbb{Z}}$ is a sequence of i.i.d. nonnegative random variables with law Q , and $c > 0$ is a positive constant. Consider again the level crossing probability

$$f_u(\lambda) = P(T_u^\lambda < \infty), \quad u > 0,$$

where

$$T_u^\lambda = \inf\{t \geq 0 : K(t) \geq u\},$$

$T_u^\lambda = \infty$ if $\{\dots\} = \emptyset$, and assume again $P(0 < Z_1 < \infty) > 0$. By the well-known Cramér-Lundberg approximation (see, for instance, Asmussen [11]) we have that, under (9.45), (9.46), and (9.47), it holds

$$\lim_{u \rightarrow \infty} e^{wu} f_u(\lambda) = -\frac{\lambda E[Z_1] - c}{\lambda E[Z_1 e^{wZ_1}] - c}. \quad (9.59)$$

In particular, this result gives the exact asymptotics for the tail of the stationary waiting time W in a $M/GI/1$ queue with arrival process $\{T_n\}_{n \geq 1}$, service times $\{Z_n\}_{n \geq 1}$, and service rate c . Indeed,

$$P(W > u) = P\left(\sup_{n \geq 1} \sum_{i=1}^n (Z_i - cX_i) > u\right) = f_u(\lambda), \quad \text{for all } u > 0,$$

where $\{X_i\}_{i \geq 1}$ are the inter-arrival times of the Poisson process.

9.4.5 Optimal estimators for sensitivity analysis in the compound Poisson case

Let $\{P_\theta\}_{\theta:\kappa(\theta)<\infty}$ be the family of probability measures defined by the exponential tilting (9.50). In the case of compound Poisson processes, Proposition 9.4.1 is an easy consequence of the law of large numbers for such processes. Moreover, we notice that Theorems 9.4.2 and 9.4.6 can be proved along similar techniques. In this subsection we prove that, in the compound Poisson setting, under the law P_w , the estimators given by the corresponding Theorem 9.4.2:

$$\hat{s}_u^{(1)} = T_u^\lambda(\phi_w(N^\lambda + \delta_{(\tau, \bar{Z})}) - \phi_w(N^\lambda)),$$

$$\hat{s}_u^{(2)} = \frac{N_{T_u^\lambda}^\lambda}{\lambda}[\phi_w(N^\lambda) - \phi_w(N^\lambda - \delta_{(\tau', Z')})]$$

and

$$\hat{s}_u^{(3)} = \frac{1}{\lambda} \int_{(0, T_u^\lambda] \times (0, \infty)} (\phi_w(N^\lambda) - \phi_w(N^\lambda - \delta_{(t, z)})) N^\lambda(dt \times dz)$$

are asymptotically optimal in a sense we are going to define. Note that by assumption (9.47) the functional ϕ_w defined in (9.52) reads

$$\phi_w(\mu) = \exp \left\{ -w \left(\sum_{n \in \mathbb{Z}} z_n \mathbf{1}_{(0, T_u^\lambda(\mu)]}(t_n) - c T_u^\lambda(\mu) \right) \right\},$$

for all (locally finite) counting measures $\mu = \sum_{n \in \mathbb{Z}} \delta_{(t_n, z_n)}$ on $\mathbb{R} \times (0, \infty)$.

The definition of optimality that will be considered is the following (see, for instance, [11]). Let $z(u)$ be an infinitesimal function, as $u \rightarrow \infty$, and \hat{r}_u an unbiased estimator of $z(u)$. As already mentioned the empirical mean is not an efficient estimator, as $u \rightarrow \infty$. Indeed, a huge number of replications of \hat{r}_u is needed to achieve a fixed relative error. To get an asymptotically efficient estimator of $z(u)$ we look for an unbiased estimator \hat{q}_u of $z(u)$ whose relative error is asymptotically bounded. Since

$$E[\hat{q}_u^2] \geq z^2(u), \quad \text{for all } u,$$

the best one can hope in terms of efficiency is

$$\lim_{u \rightarrow \infty} \frac{\sqrt{E[\hat{q}_u^2]}}{z(u)} = A,$$

for some constant $A \geq 1$. This property is often difficult to achieve in practice, so one settles for a slightly weaker condition

$$\lim_{u \rightarrow \infty} \frac{\log \sqrt{E[\hat{q}_u^2]}}{\log z(u)} = 1. \quad (9.60)$$

In such a case we say that \hat{q}_u is asymptotically optimal (as $u \rightarrow \infty$). Note that (9.60) is equivalent to

$$\liminf_{u \rightarrow \infty} \frac{\log \sqrt{E[\hat{q}_u^2]}}{\log z(u)} \geq 1.$$

Furthermore, if \hat{q}_u is an unbiased estimator of $z(u)$, and $\hat{q}_u^{(1)}, \dots, \hat{q}_u^{(n)}$ are n i.i.d. replicates of \hat{q}_u , it can be easily seen that $(1/n) \sum_{i=1}^n \hat{q}_u^{(i)}$ is asymptotically optimal for some $n \geq 2$ if and only if $\hat{q}_u^{(1)}$ is such.

The following Proposition 9.4.7 can be found in [11] (see Proposition 9.4 therein) and gives the exact asymptotics of $\frac{df_u(\lambda)}{d\lambda}$ as $u \rightarrow \infty$.

Proposition 9.4.7 Assume (9.45), (9.46), and (9.47). Then

$$\lim_{u \rightarrow \infty} \frac{e^{wu}}{u} \frac{df_u(\lambda)}{d\lambda} = \frac{c^2 w (c - \lambda E[Z_1])}{\lambda (\lambda E[Z_1 e^{wZ_1}] - c)^2}.$$

Theorem 9.4.8 below gives the asymptotic optimality of $\hat{s}_u^{(1)}$, $\hat{s}_u^{(2)}$ and $\hat{s}_u^{(3)}$ under P_w .

Theorem 9.4.8 Assume (9.45), (9.46), (9.47), and $\kappa(\cdot)$ steep, then the estimators $\hat{s}_u^{(1)}$, $\hat{s}_u^{(2)}$ and $\hat{s}_u^{(3)}$ are asymptotically optimal under P_w .

Proof. By the assumptions we deduce that $\lambda E[Z_1 e^{wZ_1}] - c > 0$, thus the hypotheses of Theorem 9.4.2 hold and we have that $\hat{s}_u^{(1)}$, $\hat{s}_u^{(2)}$ and $\hat{s}_u^{(3)}$ are unbiased estimators of $\frac{df_u(\lambda)}{d\lambda}$. It remains to prove

$$\liminf_{u \rightarrow \infty} \frac{\log \sqrt{E_w[(\hat{s}_u^{(i)})^2]}}{\log \frac{df_u(\lambda)}{d\lambda}} \geq 1, \quad \text{for } i = 1, 2, 3. \quad (9.61)$$

Along similar lines as in the proof of Lemma 9.4.3, we can show that for any (locally finite) counting measure μ on $\mathbb{R} \times (0, \infty)$ and $u > 0$, it holds $\phi_w(\mu) \leq e^{-wu}$. Therefore,

$$E_w[(\hat{s}_u^{(i)})^2] \leq e^{-2wu} E_w[(N_{T_u^\lambda}^\lambda)^2] / \lambda^2, \quad i = 2, 3. \quad (9.62)$$

and

$$E_w[(\hat{s}_u^{(1)})^2] \leq e^{-2wu} E_w[(T_u^\lambda)^2]. \quad (9.63)$$

Under P_w , $\sum_{i=1}^n (Z_i - cX_i)$ is a random walk with positive drift, indeed

$$E_w[Z_1 - cX_1] = (\lambda E[Z_1 e^{wZ_1}] - c) / \lambda \kappa(w) > 0$$

Therefore by the results in Gut [83] it follows

$$E_w[(N_{T_u^\lambda}^\lambda)^2] = E_w[(T_u^\lambda)^2] = O(u^2). \quad (9.64)$$

Finally, (9.61) follows by (9.62), (9.63), (9.64) and Proposition 9.4.7. \square

Remark 9.4.9 We notice that, under assumptions of Theorem 9.4.8, Asmussen and Rubinstein [12] (see also [11]) proved that

$$\hat{v}_u = \left(N_{T_u^\lambda}^\lambda / \lambda - T_u^\lambda \right) e^{-wu} e^{-w(C(T_u^\lambda) - cT_u^\lambda - u)}$$

is asymptotically optimal for $f_u(\lambda)$, under P_w . The estimators $\hat{s}_u^{(1)}$, $\hat{s}_u^{(2)}$ and $\hat{s}_u^{(3)}$ are alternative to \hat{v}_u .

9.5 A Numerical Illustration

In this section we give a numerical illustration. More precisely, we use two of the three estimators in Theorem 9.4.2 to approximate the sensitivity $\frac{df_u(\lambda)}{d\lambda}$, where $f_u(\lambda)$ is the overflow probability corresponding to the teletraffic model described in Example 1. We denote by \hat{s}_1 and \hat{s}_2 the "virtual" and the "phantom" estimates (respectively, the estimates corresponding to the first and the third mean in the statement of Theorem 9.4.2). The corresponding sample variances are denoted by $\sigma(\hat{s}_1)^2$ and $\sigma(\hat{s}_2)^2$.

Assuming that the random variables Z_n are exponentially distributed with mean β^{-1} such that $\beta > \lambda c^{-1}$, the steepness of $\kappa(\cdot)$ and assumptions (9.45), (9.46), and (9.47) are easily checked. In

particular, $w = \beta - \lambda c^{-1}$. Also, setting $\beta = 3$, $\lambda = 2$, $c = 1$, and taking $\widehat{\theta} \in \{0.9, 0.95\}$ condition (9.51) is satisfied and $\widehat{\theta} < w$. Thus, Theorem 9.4.2 can be applied to estimate $\frac{df_u(\lambda)}{d\lambda}$ by a Monte Carlo algorithm. In the four tables below we summarize our simulation results when the number of replications in each simulation is equal to 200, and the buffer capacity is $u \in \{0.5, 0.6, 0.7\}$. We report also the CPU time (in seconds) which shows that the "virtual" rare perturbation method is faster than the "phantom" one. However, we do not know which estimator has the best performance. Indeed, in order to build confidence intervals the key parameter is σ/\sqrt{n} , where n is the number of samples. The number of samples generated up to time t is approximately equal to t/t^* , being t^* the CPU time to generate one sample. Therefore, the key parameter to compare the performance of the two simulation methods is $\sigma\sqrt{t^*}$: the lower it is narrower is the confidence interval. It is not clear whether or not a method achieves a better performance than the other.

u	$\widehat{\theta}$	\hat{s}_1	$\sigma(\hat{s}_1)^2$	CPU time	$\sigma(\hat{s}_1)^2 \times$ CPU time
0.5	0.95	0.17	1.04	6	6.24
0.6	0.95	0.20	0.77	7	5.39
0.7	0.95	0.19	1.40	8	11.2

u	$\widehat{\theta}$	\hat{s}_2	$\sigma(\hat{s}_2)^2$	CPU time	$\sigma(\hat{s}_2)^2 \times$ CPU time
0.5	0.95	0.20	0.10	90	9
0.6	0.95	0.20	0.12	82	9.84
0.7	0.95	0.20	0.08	78	6.24

u	$\widehat{\theta}$	\hat{s}_1	$\sigma(\hat{s}_1)^2$	CPU time	$\sigma(\hat{s}_1)^2 \times$ CPU time
0.5	0.9	0.19	0.80	10	8
0.6	0.9	0.17	1.39	12	16.68
0.7	0.9	0.17	1.40	7	9.8

u	$\widehat{\theta}$	\hat{s}_2	$\sigma(\hat{s}_2)^2$	CPU time	$\sigma(\hat{s}_2)^2 \times$ CPU time
0.5	0.9	0.19	0.06	101	6.06
0.6	0.9	0.18	0.07	150	10.5
0.7	0.9	0.17	0.06	250	15

Appendix

A The Coupling Method

The coupling method is a fruitful probabilistic tool. Its range of application is large: Markov chain, renewal theory, perfect simulation or the Chen-Stein method. In this paragraph, we will record a few simple results on this method.

A.1 The Coupling Inequality

The coupling method compares two probability measures on a measurable space.

Definition A.1 *Let \mathcal{X} (resp. \mathcal{X}') be a measurable space endowed with a probability measure P (resp. P'). A coupling is a random variable (X, X') with law \mathbb{P} on $\mathcal{X} \times \mathcal{X}'$ such that the law of X is P and the law of X' is P' .*

We will assume that $\mathcal{X} = \mathcal{X}'$. When X and X' are independent we obtain a trivial coupling (Q is the product measure). However in the coupling method the aim is to build a coupling (X, X') such that a given cost function $\mathbb{E}c(X, X')$ is small, where \mathbb{E} denotes the expectation with respect to the measure \mathbb{P} . This constraint requires to introduce some dependency between X and X' . We will only discuss the case $c(x, y) = \mathbf{1}(x \neq y)$, (for a general discussion, refer to Villani [158]). In this case, the aim of the coupling is to render X and X' equal. We shall use the total variation distance of two measures to determine to what extent it is possible.

The total variation distance is defined as:

$$d(P, P') = \sup_{f:|f| \leq 1} \left| \int f dP - \int f dP' \right|,$$

where the sup is taken over all the bounded measurable functions from \mathcal{X} to \mathbb{R}_+ .

The coupling inequality is as follows:

Theorem A.2 (i) *For all coupling (X, X') of P and P' :*

$$2\mathbb{P}(X \neq X') \geq d(P, P').$$

(ii) *There exists a coupling (Y, Y') such that the previous inequality is an equality, and Y and Y' are independent conditioned on $\{Y \neq Y'\}$.*

For a proof, refer to Lindvall [115].

A.2 Stochastic Domination

Let $(\mathcal{X}, \mathcal{F})$ be a complete separable measurable (polish) space with a partial ordering \preceq . A real valued function is non-decreasing $x \preceq y$ implies $f(x) \leq f(y)$.

We consider two measures P and P' on \mathcal{X} . The stochastic ordering associated to \preceq is defined by:

$$P \preceq_{st} P' \quad \text{if and only if} \quad \int f dP \leq \int f dP',$$

for all non-decreasing measurable function. We will consider also the formulation with random variables instead of probability measures. For two random variables X and X' on \mathcal{X} , we use the notation $X \preceq_{st} X'$ if the law of X is dominated by the law of X' .

Strassen's Theorem shows that the stochastic ordering \preceq_{st} corresponds to the ordering \preceq through a coupling. Note first that if (X, X') is a random variable with law \mathbb{P} on $\mathcal{X} \times \mathcal{X}$ satisfying \mathbb{P} -a.s. $X \preceq X'$, then $X \preceq_{st} X'$. Strassen's Theorem is the converse statement.

Theorem A.3 *If P and P' are probability measures on $(\mathcal{X}, \mathcal{F})$ satisfying $P \preceq_{st} P'$, then there exists a coupling (X, X') with law \mathbb{P} such that*

$$\mathbb{P} - a.s., \quad X \preceq X'.$$

B Point processes

B.1 Vague convergence of locally finite measures

Let \mathcal{X} be a Polish space (complete separable metric space). A measure μ on \mathcal{X} is locally finite if $\mu(A)$ is finite for all bounded Borel set A .

We define \mathcal{M} as the set of locally finite measures on \mathcal{X} , and \mathcal{C}_b the set of continuous functions on \mathcal{X} with bounded support. The vague convergence on \mathcal{M} is defined by

$$\mu_k \Rightarrow \mu \quad \text{if for all } f \in \mathcal{C}_b, \quad \lim_{k \rightarrow \infty} \int f d\mu_k = \int f d\mu.$$

It can be shown that the vague convergence is compatible with a distance d , that is there exists a distance on \mathcal{M} such that $\mu_k \Rightarrow \mu$ if and only if $d(\mu_k, \mu) \rightarrow 0$. This distance generates a topology, the next theorem is central (for a proof refer to Daley and Vere Jones [55]).

Theorem B.1 *\mathcal{M} is a Polish space for the topology induced by the vague convergence.*

The following lemma is an adaptation of Theorem 5.2 of Billingsley [30] to the vague topology (see Proposition A.2.6.II of [55]). We define the *discontinuity set* of a function h as $disc(h) = \{x : h(x) \text{ not continuous at } x\}$.

Lemma B.2 *Let μ_k be a sequence in \mathcal{M} converging for the vague convergence toward μ . Let h be a bounded measurable function with $\mu(disc(h)) = 0$ and A a bounded Borel set of \mathbb{R}^d with $\mu(\partial A) = 0$, then: $\lim_k \int_A h(x) \mu_k(dx) = \int_A h(x) \mu(dx)$*

B.2 Stationary Point Process and Palm Theory

Palm theory is a powerful tool for the analysis of stationary point processes. In this section, we sketch its classical construction. In dimension 1 a full treatment of this theory may be found in Baccelli and Brémaud [20], in any dimension refer to Kallenberg [98], Daley and Vere-Jones [55].

Let \mathcal{K} be a Polish space and let \mathcal{M} be the set of simple locally finite counting measures m on $\mathcal{X} = \mathbb{R}^d \times \mathcal{K}$ such that $m(\cdot \times \mathcal{K})$ is a Radon measure. m is referred as a marked counting measure on \mathbb{R}^d with marks in \mathcal{K} . A counting measure is *simple* if for all $x \in \mathcal{X}$, $m(\{x\}) \in \{0, 1\}$.

Let $m \in \mathcal{M}$, $x \in \mathbb{R}^d$, we define the *shifted measure* $\theta_x m$ by

$$\theta_x m(C \times B) = m(S_x C \times B),$$

where $C \in \mathcal{B}_{\mathbb{R}^d}$, the Borel σ -algebra on \mathbb{R}^d , $B \in \mathcal{B}_{\mathcal{X}}$, and $S_x C = \{y \in \mathbb{R}^d : y - x \in C\}$.

A *marked point process* is a random variable on $(\mathcal{M}, \mathcal{F})$, where \mathcal{F} is the Borel σ -algebra generated by the vague topology. Let \mathbb{P} be a probability measure on $(\mathcal{M}, \mathcal{F})$ and N a marked point process with law \mathbb{P} .

A marked point process is *stationary* if for all $x \in \mathbb{R}^d$:

$$\mathbb{P} \circ \theta_x = \mathbb{P}.$$

Let N be a stationary marked point process such that for all compact sets C , $\mathbb{E}N(C \times \mathcal{K})$ is finite. $C \mapsto \mathbb{E}N(C \times \mathcal{K})$ is a Radon measure. Moreover by stationarity, $\mathbb{E}N(S_x C \times \mathcal{K}) = \mathbb{E}N(C \times \mathcal{K})$, therefore, this measure is absolutely continuous with respect to the Lebesgue measure. The intensity of N is defined as Radon-Nykodym derivative of this measure with respect to the Lebesgue measure:

$$\lambda = \frac{\mathbb{E}N(C \times \mathcal{K})}{\nu(C)},$$

where ν is the Lebesgue measure on \mathbb{R}^d .

The Palm probability \mathbb{P}_N^0 is a probability measure on $(\mathcal{M}, \mathcal{F})$ defined by, for a Borel set C with $\nu(C) > 0$,

$$\mathbb{P}_N^0(A) = \frac{1}{\lambda \nu(C)} \mathbb{E} \int_C \mathbf{1}(\theta_x N \in A) N(dx \times \mathcal{K}).$$

By stationarity, this definition does depend of the choice of C . Set $A = \{N(\{0\} \times \mathcal{K}) = 1\}$, we have $\mathbb{P}_N^0(A) = 1$. Under the Palm distribution, there is \mathbb{P}_N^0 -a.s. an atom at 0.

E_N^0 will denote the expectation with respect to the Palm distribution \mathbb{P}_N^0 . The next Proposition is the celebrated Campbell-Mecke Formula.

Proposition B.3 *Let N be a stationary point process in \mathcal{M} with finite intensity. Let f be a bounded measurable $\mathbb{R}^d \times \mathcal{M} \rightarrow \mathbb{R}$ function with compact support on \mathbb{R}^d .*

$$\mathbb{E} \int_{\mathcal{X}} f(x, \theta_x N) N(dx) = \lambda \int_{\mathbb{R}^d} \mathbb{E}_N^0 f(x, N) dx.$$

Set $N = \sum_{n \in \mathbb{N}} \delta_{\{X_n, Z_n\}}$, X_0 the point closer to the origin, and $f(x, m) = g(x, m(\{0\} \times \cdot))$, the Campbell-Mecke Formula reads:

$$\mathbb{E} \sum_n g(X_n, Z_n) = \lambda \int_{\mathbb{R}^d} \mathbb{E}_N^0 g(x, Z_0) dx.$$

Set $h(x, m)$ such that for \mathbb{P}_N^0 -a.e.

$$\int_{\mathbb{R}^d} h(x, m) m(dx) = 1. \tag{10.1}$$

Applying Campbell-Mecke Formula to $f(x, m) = h(x, \theta_{-x} m) g(\theta_{-x} m)$, we obtain the inversion formula.

Proposition B.4 *Let g be a bounded measurable $\mathcal{M} \rightarrow \mathbb{R}$ function.*

$$\mathbb{E}g(N) = \lambda \mathbb{E}_N^0 \int_{\mathbb{R}^d} h(x, \theta_{-x} N) g(\theta_{-x} N) dx.$$

Set $m = \sum_{n \in \mathbb{N}} \delta_{\{x_n, z_n\}}$ in \mathcal{M} . A classical example is the function $h(x, m) = \mathbb{1}(x \in V_0(m))$, where x_0 is the point closest to the origin and $V_0(m)$ is the Voronoi cell associated to x_0 : $V_0(m) = \{x \in \mathbb{R}^d : \forall n, \|x - X_0\| \leq \|x - X_n\|\}$, ($\|\cdot\|$ denotes the usual Euclidean norm). h satisfies Equation (10.1) and the inversion formula reads:

$$\mathbb{E}g(N) = \lambda \mathbb{E}_N^0 \int_{V_0(N)} g(\theta_{-x}N) dx.$$

The couple (\mathbb{P}, θ) is *ergodic* if for all events A such that for all x , $\theta_x A = A$, $\mathbb{P}(A) \in \{0, 1\}$. The following is an application of Birkhoff's Theorem to ergodic point processes.

Proposition B.5 *Let $B_n = B(0, r_n)$ be the open ball of radius r_n and center 0. We assume that $(r_n)_{n \in \mathbb{N}}$ is increasing and converges to infinity. If the point process N is ergodic and has finite intensity then for all $f \in L^1(P)$, \mathbb{P} -a.s. and \mathbb{P}_N^0 -a.s.*

$$\lim_n \frac{1}{\nu(B_n)} \int_{B_n} f(\theta_x N) dx = \mathbb{E}f(N).$$

Similarly for all $f \in L^1(P_N^0)$, \mathbb{P} -a.s. and \mathbb{P}_N^0 -a.s.

$$\lim_n \frac{1}{N(B_n)} \int_{B_n} f(\theta_x N) N(dx) = \mathbb{E}_N^0 f(N).$$

B.3 Poisson point processes and Slivnyak-Campbell Formula

A stationary point process on \mathbb{R}^d is a Poisson point process of intensity λ if

- For all Borel sets C , $N(C)$ has a Poisson distribution with parameter $\lambda\nu(C)$.
- If $C \cap D = \emptyset$, then $N(C)$ and $N(D)$ are independent.

Slyvniak's Theorem asserts that the Palm distribution of a Poisson point process is simply:

$$\mathbb{P}_N^0 = \mathbb{P} * \delta_0,$$

that is, for all events A : $\mathbb{P}_N^0(A) = \mathbb{P}(N + \delta_0 \in A)$. A Poisson point process in its Palm version is simply a Poisson point process with an atom added at the origin.

The following proposition is the Slyvniak-Campbell Formula, this is a generalization of Campbell formula.

Proposition B.6 *If f is a bounded measurable $(\mathbb{R}^d)^n \times \mathcal{M} \rightarrow \mathbb{R}$ function. If N is a Poisson point process*

$$\mathbb{E} \sum_{\{X_1, \dots, X_n\} \subset N} f(\{X_1, \dots, X_n\}, N) = \frac{\lambda^n}{n!} \int_{(\mathbb{R}^d)^n} f\left(\{x_1, \dots, x_n\}, N + \sum_{k=1}^n \delta_{x_k}\right) dx_1 \cdots dx_n,$$

where the sum is over all subsets of n distinct points of N .

$N = \sum_n \delta_{\{X_n, Z_n\}}$ is a independently marked Poisson point process on \mathbb{R}^d with marks in \mathcal{K} of intensity λ if $N(\cdot \times \mathcal{K})$ is a Poisson point process of intensity λ and if the marks (Z_n) are iid and independent of $N(\cdot \times \mathcal{K})$. If the law of Z_0 is denoted by Q , N is a non-homogeneous Poisson point process of intensity measure $\lambda dx Q(dz)$. Slyvniak's Theorem extends to independently marked Poisson point processes: $\mathbb{P}_N^0(A) = \mathbb{P}(N + \delta_{\{0, Z\}} \in A)$, where Z has law Q and is independent of N . Slivnyak-Campbell Formula extends as follows:

$$\mathbb{E} \sum_{\{(X_1, Z_1), \dots, (X_n, Z_n)\} \subset N} f(\{(X_1, Z_1), \dots, (X_n, Z_n)\}, N) = \quad (10.2)$$

$$\frac{\lambda^n}{n!} \int_{(\mathbb{R}^d \times \mathcal{K})^n} f\left(\{x_1, \dots, x_n\}, N + \sum_{k=1}^n \delta_{\{x_k, z_k\}}\right) dx_1 \cdots dx_n Q(dz_1) \cdots Q(dz_n).$$

C Queueing Theory

C.1 Loynes' Sequence for stochastic recurrences

The material of this present paragraph is taken from Baccelli and Brémaud [20]. Let space \mathcal{X} be a Polish space endowed with a partial order \preceq such that:

- there exists a minimal point in \mathcal{X} denoted by 0,
- all non-decreasing sequences converge in the closure of \mathcal{X} , $\overline{\mathcal{X}}$.

The workload of a queueing system often satisfies a *stochastic recurrence*:

$$W_{n+1} = h(W_n, \xi_n), \quad (10.3)$$

where, $n \in \mathbb{N}$ represents the time, $(W_n)_{n \in \mathbb{N}}$ is the workload sequence in \mathcal{X} with $0 \preceq W_n$, h is a measurable function, and $(\xi_n)_{n \in \mathbb{Z}}$ is a driving sequence taking value in some measurable space Ω . The driving sequence $(\xi_n)_{n \in \mathbb{Z}}$ is a random variable on the state space $(\Omega, \mathcal{F}, \mathbb{P})$, it is assumed to be compatible with an ergodic shift operator θ : for $n \in \mathbb{Z}$, $\xi_n = \xi \circ \theta^n$, where $\xi_0 = \xi$.

A stationary solution of Equation (10.3) is a variable satisfying:

$$W \circ \theta = h(W, \xi_n),$$

indeed since the shift is stationary, $W \circ \theta$ and W have the same law.

The *Loynes's sequence* $(M_n)_{n \in \mathbb{N}}$ builds a stationary solution. It is defined as the workload at time 0 when the workload was 0 at time $-n$, that is:

$$M_n = W_n^0 \circ \theta_{-n},$$

where W_n^Y is the workload at time n when $W_0 = Y$. Assume that the function h satisfies:

- (i) $0 \preceq h(W, \xi)$ for all W and ξ .
- (ii) $W \preceq W'$ implies $h(W, \xi) \preceq h(W', \xi)$.

From Assumption (i), $0 \preceq h(0, \xi_{-(n+1)}) = W_1^0 \circ \theta_{-(n+1)}$. From Assumption (ii), iterating n times by h , it follows:

$$M_n \preceq M_{n+1}.$$

$(M_n)_{n \in \mathbb{N}}$ is a nondecreasing sequence, therefore it converges in $\overline{\mathcal{X}}$ to the *Loynes's variable*:

$$M = \lim_{n \rightarrow +\infty} M_n.$$

Secondly, notice that $M_{n+1} \circ \theta = W_{n+1}^0 \circ \theta_{-n}$, hence

$$M_{n+1} \circ \theta = h(M_n, \xi).$$

Note that the event $A = \{\exists N : M_N = M\}$ is an invariant event: indeed, $A = \{\exists N \geq 1 : \forall n \geq N, M_{n+1} = M_n\}$ thus

$$\theta^{-1}A = \{\exists N \geq 1 : \forall n \geq N, M_{n+1} \circ \theta = M_n \circ \theta\} = \{\exists N \geq 1 : \forall n \geq N, h(M_n, \xi) = h(M_{n-1}, \xi)\} \supset A.$$

By ergodicity:

$$\mathbb{P}(A) \in \{0, 1\}.$$

Thus if $\mathbb{P}(A) = 1$, $M \in \mathcal{X}$, \mathbb{P} -a.s., and M satisfies:

$$M \circ \theta = h(M, \xi).$$

The Loynes' variable is a stationary solution.

It is also important to note that $M_n \preceq M$. Moreover, by stationarity, the laws of W_n^0 and M_n are identical, therefore (see §A.2 on stochastic domination):

$$\text{for all } n \in \mathbb{N}: \quad W_n^0 \preceq_{st} M,$$

the Loynes's variable dominates the workload started empty. We will illustrate this nice property in the next paragraph.

C.2 Tail Inequality in the GI/GI/ ∞

Let $\{\sigma_n, \tau_n\}, n \in \mathbb{Z}$, be an i.i.d. sequence of $\mathbb{R}_+ \times \mathbb{R}_+$ -valued random variables representing the service times and inter-arrival times in a GI/GI/ ∞ queue. The random variables (σ_n) and (τ_n) are independent. We set $T_0 = 0$ as the arrival time of customer 0; for $n \geq 1$, $T_n = \sum_{k=0}^{n-1} \tau_k$ is the arrival time of the n^{th} customer. Let $Y \in \mathbb{R}_+$ be a non-negative initial condition, independent of the $\{\sigma_n, \tau_n\}$ sequence. We set $W_0^{[Y]} = Y$, and for $n \geq 1$, we define

$$\begin{aligned} W_n^{[Y]} &= \max \left(Y - \sum_{k=0}^{n-1} \tau_k, \max_{1 \leq i \leq n} \sigma_{i-1} - \sum_{k=i}^{n-1} \tau_k \right)^+ \\ &= \max \left(Y - (T_n - T_0), \max_{1 \leq i \leq n} \sigma_{i-1} - (T_n - T_i) \right)^+ \\ &= \max \left(W_{n-1}^{[Y]} - \tau_{n-1}, \sigma_{n-1} \right). \end{aligned}$$

(where by convention $\sum_{k=n}^{n-1} \cdot = 0$). The random variable $W_n^{[Y]}$ is the largest residual service time just after the arrival of the n^{th} customer in the GI/GI/ ∞ queue with initial condition Y .

Let \mathcal{F}_n be the σ -field generated by the random variables Y and $\{(\sigma_k, \tau_k), k = 0, \dots, n-1\}$. Consider the $\{\mathcal{F}_n\}$ -stopping time:

$$\theta(Y) = \theta = \inf\{n \geq 1 : W_n^{[Y]} = 0\}. \quad (10.4)$$

θ is the time needed to empty all queues.

Light Tail Case

The following additional assumptions are made:

- (i) There exist a constant $s > 0$ such that : $\mathbb{E} \exp(s\sigma_1) < \infty$ and $\mathbb{E} \exp(sY) < \infty$.
- (ii) $\mathbb{P}(\tau_1 > 0) > 0$.
- (ii) $\mathbb{P}(\sigma_1 = 0) > 0$.

Lemma C.1 *Let θ be the stopping time defined in Equation (10.4). Under the foregoing probabilistic assumptions on Y , (τ_n) and (σ_n) , there exists $s > 0$ such that:*

$$\mathbb{E} \exp(s\theta) < \infty.$$

Proof. The Loynes' sequence $\{M_n\}$ of this GI/GI/ ∞ queue is defined by $M_0 = 0$ and

$$M_n = \max_{-n+1 \leq i \leq 0} (\sigma_{i-1} - \sum_{k=i}^{-1} \tau_k)^+, \quad n \geq 1.$$

This sequence is non-decreasing in n and it a.s. converges to

$$M = \sup_{i \leq 0} (\sigma_{i-1} - \sum_{k=i}^{-1} \tau_k)^+. \quad (10.5)$$

The random variable M is a.s. finite. Indeed, we can easily obtain a stronger assertion. Let $s > 0$ such that $\mathbb{E} \exp(s\sigma_1) < \infty$ (such s exists due to Assumption (i)), then:

$$\begin{aligned} \mathbb{E} \exp(sM) &= \mathbb{E} \exp(s \sup_{i \leq 0} (\sigma_{i-1} - \sum_{k=i}^{-1} \tau_k)^+) \\ &\leq 1 + \sum_{i \leq 0} \mathbb{E} \exp(s(\sigma_{i-1} - \sum_{k=i}^{-1} \tau_k)) \\ &\leq 1 + \mathbb{E} \exp(s\sigma_1) \sum_{i \leq 0} \mathbb{E} \exp(-s|i|\tau_1) < \infty. \end{aligned}$$

Now, we define :

$$\nu(Y) = \nu = \inf\{n \geq 2 : Y - \sum_{k=0}^{n-1} \tau_k < 0\}. \quad (10.6)$$

From time ν on, the initial workload does not count anymore, i.e. for $n \geq \nu$ $W_n^{[Y]} = \max_{2 \leq i \leq n} (\sigma_{i-1} - T_n + T_{i-1})^+$. Note that ν has the same distribution as

$$\nu' = \max\{n \leq -1 : Y - \sum_{k=n}^{-1} \tau_k < 0\}.$$

More generally,

$$\left(\sum_{k=0}^{\nu-1} \tau_k, \sum_{k=1}^{\nu-1} \tau_k, \dots, \tau_{\nu-1} \right) \stackrel{\mathcal{L}}{=} \left(\sum_{k=-\nu'}^{-1} \tau_k, \sum_{k=-\nu'+1}^{-1} \tau_k, \dots, \tau_{-1} \right),$$

which implies that $M_{\nu'}$ and $W_{\nu'}^{[Y]}$ have the same distribution. Since $M_{\nu'} \leq M$, we have

$$W_{\nu'}^{[Y]} \leq_{st} M. \quad (10.7)$$

Note that this bound is uniform in Y .

From Assumption (ii) we may find $c > 0$ and $\epsilon > 0$ such that $\mathbb{P}(\tau_1 \geq c) \geq \epsilon$. Let $B_k = c\mathbf{1}(\tau_k \geq c)$. Using the independency between τ and Y and Hoeffding's inequality:

$$\mathbb{P}(\nu > n) \leq \mathbb{P}\left(\sum_{k=0}^{n-1} B_k < Y\right) \leq \mathbb{E} \exp\left(-\frac{(c\epsilon n - Y)^2}{2c^2 n}\right).$$

By assumption (i), Y is such that $\mathbb{P}(Y > t) \leq C_1 \exp(-C_0 t)$, for some positive constants C_0, C_1 , hence:

$$\mathbb{P}(\nu > n) \leq \mathbb{P}(Y > nt_0) + \exp\left(-\frac{(c\epsilon n - nt_0)^2}{2c^2 n}\right) \leq C_1 \exp(-C_0 n). \quad (10.8)$$

for some positive constants C_0, C_1 , uniformly on the initial conditions Y . Hence we may found some $s > 0$ such that $\mathbb{E} \exp(s\nu) < \infty$.

The sequence $\{W_n^{[Y]}\}$ is a $\{\mathcal{F}_n\}$ -Markov chain and the random variables

$$\nu_{n+1} = \nu_n + \nu(W_{\nu_n}^{[Y]}), \quad n \geq 1,$$

with $\nu(W)$ defined in (10.6) and with $\nu_1 = \nu = \nu(Y)$, are $\{\mathcal{F}_n\}$ -stopping times. Using what precedes, one gets by induction that each ν_n is a.s. finite and that for all n ,

$$\mathbb{P}(\nu_{n+1} - \nu_n > m | \mathcal{F}_{\nu_n}) = \mathbb{P}(\nu_{n+1} - \nu_n > m | W_{\nu_n}^{[Y]}) \leq C_1 \exp(-C_0 m), \quad \forall m \quad (10.9)$$

$$\mathbb{P}(W_{\nu_{n+1}}^{[Y]} > x | \mathcal{F}_{\nu_n}) = \mathbb{P}(W_{\nu_{n+1}}^{[Y]} > x | W_{\nu_n}^{[Y]}) \leq \mathbb{P}(M > x), \quad \forall x. \quad (10.10)$$

Using (10.9) and a Chernoff type bound, one gets

$$\mathbb{P}(\nu_n > \alpha n) \leq C_1 \exp(-C_0 n), \quad (10.11)$$

for some positive constants α, C_0, C_1 .

We now turn back to the stopping time θ . First we prove that $\mathbb{P}(M = 0) = p_0 > 0$. M is the stationary solution of the Markov Chain. Let M_n be this stationary sequence, $M_1 \stackrel{\mathcal{L}}{=} M_2 = \max(M_1 - \tau_1, \sigma_1)$, $\mathbb{P}(M_1 = 0) = \mathbb{P}(M_1 \leq \tau) \mathbb{P}(\sigma_1 = 0)$. Then assume that $M > 0$ a.s.. By assumption (iii) $\mathbb{P}(\sigma_1 = 0) > 0$ then $M_1 > \tau_1$ a.s.. The independence of M_1 and τ_1 implies that $M > c$ almost surely. Notice that $\mathbb{P}(M < c) \geq \mathbb{P}(M_1 - \tau_1 < 2c) \mathbb{P}(\sigma_1 = 0) \geq \mathbb{P}(c < M \leq 2c) \mathbb{P}(\tau_1 > c) \mathbb{P}(\sigma_1 = 0)$, hence $M > c$ a.s. implies $M > 2c$ a.s.. By iteration, we get for all n $M > nc$ a.s. and this contradicts the finiteness of M .

Equation (10.9) implies that $\mathbb{P}(W_{\nu_{n+1}}^{[Y]} = 0 | \mathcal{F}_{\nu_n}) \geq \mathbb{P}(M = 0) = p_0$. In the same vein of what precedes when using (10.11) and (10.10), one gets that:

$$P(\theta > n) \leq (1 - p_0)^{\lfloor n/\alpha \rfloor} + P(\nu_{\lfloor n/\alpha \rfloor} > n) \leq C_1 e^{-C_0 n},$$

for some positive constants C_0, C_1 . □

Heavy Tail Case

In this paragraph, the probabilistic assumptions are made:

- (i) There exist a constant $\alpha > 1$ such that : $\mathbb{P}(\sigma_1 > t) \leq C_1 t^{-\alpha}$ and $\mathbb{P}(Y > t) \leq C_1 t^{1-\alpha}$.
- (ii) $\mathbb{P}(\tau_1 > 0) > 0$.
- (ii) $\mathbb{P}(\sigma_1 = 0) > 0$.

Lemma C.2 *Let θ be the stopping time defined in Equation (10.4). Under the foregoing probabilistic assumptions on Y , (τ_n) and (σ_n) , θ is a.s. finite. Moreover if $\alpha > 2$, there exists $C_1 > 0$ such that:*

$$\mathbb{E}\theta < \infty \quad \text{and} \quad \mathbb{P}(\theta > t) \leq C_1 t^{2-\alpha}.$$

Proof. The proof follows the proof of Lemma C.1 in almost all aspects. We only outline the proof. The tail of the stationary solution M is bounded differently. Let $a > 0$, we notice that:

$$\mathbb{P}(\sup_{i \geq 0} (\sigma_i - ia) \geq t) = 1 - \prod_{i \geq 0} (1 - \mathbb{P}(\sigma_1 \geq t + ia)) \leq C_1 t^{1-\alpha}.$$

From Assumption (ii) we may find $c > 0$ and $\epsilon > 0$ such that $\mathbb{P}(\tau_1 \geq c) \geq \epsilon$. Let $B_k = c\mathbf{1}(\tau_k)$. Fix $0 < a < c\epsilon$ and let $T = \inf\{n : \forall n \geq i, \sum_{k=1}^i \tau_k \geq ia\}$, it follows from Hoeffding's Inequality that $\mathbb{P}(T \geq n) \leq C_0 \exp(-C_1 n)$. Then we have:

$$\mathbb{P}(M \geq t) \leq \mathbb{P}(T \geq n) + \mathbb{P}(\max(\sigma_1, \dots, \sigma_n) \geq t) + \mathbb{P}(\sup_{i \geq 0} (\sigma_i - ia) \geq t) \quad (10.12)$$

$$\leq C_1 t^{1-\alpha}, \quad (10.13)$$

(we pick $n = \lfloor t^\gamma \rfloor$, $0 < \gamma \leq 1$). We obtain similarly that:

$$\mathbb{P}(\nu_{n+1} - \nu_n > m | \mathcal{F}_{\nu_n}) \leq C_1 m^{1-\alpha}.$$

where ν was defined as in the proof of Lemma C.1 by Equation (10.6). In particular, since $\alpha > 2$, $\mathbb{E}(\nu_{n+1} - \nu_n | \mathcal{F}_{\nu_n}) \leq \lambda$, for some $\lambda > 0$. The relation $\mathbb{P}(W_{\nu_{n+1}}^{[Y]} = 0 | \mathcal{F}_{\nu_n}) \geq \mathbb{P}(M = 0) = p_0$ still holds. Then, from Doob formula we get $\mathbb{E}(\theta)p_0/\lambda \leq 1$. The statement on the tail of θ follows from a moderate deviation result of Baum and Katz (Theorem 4 in [27]): $\mathbb{P}(\nu_{n+1} - \nu_n > m | \mathcal{F}_{\nu_n}) \leq C_1 m^{1-\alpha}$ implies that $\mathbb{P}(\nu_n \geq \epsilon n) \leq C_1 n^{2-\alpha}$ for $\epsilon < \lambda$. The proof is then parallel to the proof of Lemma C.1. \square

D A spatial network paradigm

The development of wireless networks has created a variety of new problems for mathematicians. It is a difficult exercise to unify these problems in a single family. However, this paragraph is an attempt to describe a general paradigm for spatial networks. This paradigm may be depicted as a transport of measures.

On a metric space, say the Euclidean space \mathbb{R}^d , some sources have some pieces of information to transport to a destination set. The source i is located at a point X_i in \mathbb{R}^d and its destination set is a collection of points $(Y_{ij})_j$. Two particular classes of problems are interesting. Each source wants to reach a specific point: the destination set is a unique point. The other class corresponds to a network where all the sources want to reach the same destination set.

The measure associated to the sources is an atomic measure written as

$$\mu = \sum_i h_i \delta_{X_i},$$

where δ_X is a dirac measure at X and $h_i \in \mathbb{R}_+$ is the amount of information that the source i transports to its destination set. The destination measure is equal to

$$\nu = \sum_{i,j} h_{ij} \delta_{Y_{i,j}} \quad \text{with} \quad h_i = \sum_j h_{ij}.$$

This scenario is static and the question is: is it possible to transport μ to ν ? In a probabilistic setting, we would like to compute the probability of this event.

It remains to define the cost of transporting the measure μ to ν . If the sources are using the same communication channel, the interference between the sources has to be taken into account. Information theory gives the right parameter to evaluate the effect of this interference. It is given by the signal to interference ratio (SIR). The cost function will be equal to the inverse of the SIR:

$$c(X_i, Y) = \frac{\eta(Y) + \sum_{k \neq i} S_k L(X_k, Y)}{S_i L(X_i, Y)},$$

where $\eta(Y) > 0$ is the power of a gaussian white noise at Y , $S_k > 0$ is the power of the signal emitted by the source k and $L(X, Y)$ is the path gain between X and Y . The path gain $L(X, Y)$

tends to 0 as the distance between X and Y tends to infinity. $I(Y) = \sum_k S_k L(X_k, Y)$ is a shot-noise process which evaluates the interference at Y . If the background noise is negligible this cost function reduces to:

$$c(X_i, Y) = \frac{I(Y)}{S_i L(X_i, Y)} - 1.$$

A simple model is $L(X, Y) = \|X - Y\|^{-\alpha}$, and an even simpler $L(X, Y) = \mathbf{1}(\|X - Y\| < r)$, where $r > 0$ is a positive range (the cost is then infinite beyond this range).

In the transport of measure, what matters is not the total cost of the transport, but the maximum of the cost at each destination point. The transport from μ to ν will be feasible if

$$\text{for all } i \text{ and } j, \quad h_{ij} c(X_i, Y_{ij}) \leq 1. \quad (10.14)$$

Indeed, in first approximation, the information theory predicts that the amount of information that can be send is proportional to the SIR.

An important feature of spatial networks is the spacial reuse property. The interference created by a source located at X decreases with distance.

Let give some examples drawn from the chapters of the Part II. In Chapter 4, we describe the simplest model. All sources want to reach the same point, say 0. The path gain is $L(X, 0) = 1$, the background noise $\eta(0) = 0$, and the power of the signal $S_i = h_i$, $h_i \in \{0, 1\}$ is a random variable. With the convention that $0 \times \infty = 0$, Equation (10.14) is restated as

$$\sum_i h_i \leq 1,$$

that is, at most one source at the same time.

In Chapter 5 the sources are located at the vertices of a graph, $G = (V, E)$ with $V = \{1, \dots, K\}$ is the set of vertices and E the set of edges. To simplify the model, the sources located at k want to reach a destination at $Y_k = k$. The path gain is

$$L(l, k) = \mathbf{1}((l, k) \in E),$$

$\eta(0) = 0$, $S_i = h_i$, $h_i \in \{0, 1\}$ is a random variable. If N_k denotes the set of sources located at k and V_k the set of vertices sharing an edge with k (including k), Equation (10.14) gives:

$$\text{for all } k \in \{1, \dots, K\}, \quad \sum_{l \in V_k} \sum_{i \in N_l} h_i \leq 1.$$

In Chapters 6 and 7, we present a model in the Euclidean space \mathbb{R}^d . All the sources want to reach the same destination set $(Y_j)_j$. Y_j is a server station and it serves the source at a rate depending on the position of the source. Formally, it will amount to suppose $S_i = 1$ and $\eta(Y) = 0$. Equation (10.14) is a constraint of the type

$$\text{for all } i \text{ and } j, \quad h_{ij} \frac{I(Y_j)}{L(X_i, Y_j)} \leq 1.$$

In Chapters 6 and 7, the destination set is a set of server stations. These stations are coordinated, and the transport problem relies on an optimization of the transport capacity of the whole system. If $\mathcal{H} = \{h = (h_{ij})_{ij} : \sum_j h_{ij} = h_i, h_{ij} \geq 0\}$, Equation (10.14) reduces to a combinatorial optimization problem

$$\inf_{h \in \mathcal{H}} \sup_{i,j} h_{ij} C(X_i, Y_{ij}) \leq 1 \quad ?$$

On the contrary in Chapters 4 and 5, there is no coordination in the transport, the source compete for the same resource. In Chapter 4, all the sources compete together, whereas in Chapter 5, the sources compete only among a local neighborhood.

Bibliography

- [1] N. Abramson. The aloha system - another alternative for computer communications. *Proc. of AFIPS press*, 37, 1970.
- [2] I.F. Akyildiz, W. Su, Y. Sankarasubramaniam, and E. Cayirci. Wireless sensor networks: a survey. *Computer Networks*, 38:393–422, 2002.
- [3] D. Aldous. Ultimate instability of exponential back-off protocol for acknowledgement-based transmission control of random access communication channels. *IEEE trans. on Information Theory*, 33, 1987.
- [4] D. Aldous. Near minimal spanning tree: the scaling exponent in probability models (*incomplete*). <http://www.stat.berkeley.edu/~aldous/Unpub/nmst.pdf>, 2006.
- [5] D. Aldous and J. M. Steele. The objective method: probabilistic combinatorial optimization and local weak convergence. 110:1–72, 2004.
- [6] Kenneth S. Alexander. The RSW theorem for continuum percolation and the CLT for Euclidean minimal spanning trees. *Ann. Appl. Probab.*, 6(2):466–494, 1996.
- [7] K.S. Alexander. Percolation and minimal spanning trees in infinite graphs. *Annals of Probability*, 23:87–104, 1995.
- [8] L. Alvarez, Y. Gousseau, and J.-M. Morel. The size of objects in natural and artificial images. *Advances in Imaging and Electron Physics*, 111:167–242, 1999.
- [9] R. V. Ambartzumian. Convex polygons and random tessellations. In E.F. Harding and D.G. Kendall, editors, *Stochastic geometry*, pages 176–191. Wiley, 1974.
- [10] M. Armony and N. Bambos. Queueing dynamics and maximal throughput scheduling in switched processing systems. *Queueing Syst.*, 44:209–252, 2003.
- [11] S. Asmussen. *Ruin probabilities*. World Scientific, Singapore, 2000.
- [12] S. Asmussen and R. Y. Rubinstein. Sensitivity analysis of insurance risk models. *Management Science*, 45:1125–1141, 1999.
- [13] K.B. Athreya and P. Ney. A new approach to the limit theory of recurrent markov chains. *Trans. Amer. Math. Soc.*, 245:493–501, 1978.
- [14] F. Baccelli, B. Blaszczynszyn, and M. Karray. Up and downlink admission/congestion control maximal load in large homogeneous cdma networks. *MONET*, 10, 2005.
- [15] F. Baccelli, B. Blaszczynszyn, and F. Tournois. Downlink admission /congestion control and maximal load in large cdma networks. In *Proceedings of INFOCOM 03*, 2003.

- [16] F. Baccelli and C. Bordenave. The radial spanning tree of a poisson point process. *submitted to Ann. Appl. Probab.*, 2005.
- [17] F. Baccelli and C. Bordenave. The radial spanning tree of a poisson point process. *43th Allerton Conference on Communication, Control and Computing*, 2005.
- [18] F. Baccelli and C. Bordenave. The radial spanning tree of a poisson point process. *INRIA Research Report*, RR 5907, 2005.
- [19] F. Baccelli and P. Brémaud. Virtual customers in sensitivity and light traffic analysis via campbell's formula for point processes. *Adv. Appl. Probab.*, 25:221–234, 1993.
- [20] F. Baccelli and P. Brémaud. *Elements of Queuing Theory*. Applications of Mathematics. Springer, Berlin, second edition, 2003.
- [21] F. Baccelli and S. Foss. On the saturation rule for the stability of queues. *J. Appl. Probab.*, 32(2):494–507, 1995.
- [22] F. Baccelli, S. Hasenfuss, and V. Schmidt. Differentiability of functionals of poisson processes via coupling with applications to queueing theory. *Stoc. Proc. Appl.*, 81:299–321, 1999.
- [23] F. Baccelli, K. Tchoumatchenko, and S. Zuyev. Markov paths on the poisson-delaunay graph with applications to routing in mobile networks. *Adv. in Appl. Probab.*, 32(1):1–18, 2000.
- [24] N. Bambos and G. Michailidis. Queueing and scheduling in random environments. *Adv. in Appl. Probab.*, 36:293–317, 2004.
- [25] N. Bambos and G. Michailidis. Queueing networks of random link topology. *Queueing Systems*, 50:5–52, 2005.
- [26] N. Bambos, G. Michailidis, and K. Wasserman. Optimal processor allocation to differentiated job flows. *Performance Evaluation*, 63:1–14, 2005.
- [27] L.E. Baum and M. Katz. Convergence rates in the law of large numbers. *Trans. Amer. Math. Soc.*, 120:108–123, 1965.
- [28] A.G. Bhatt and R. Roy. On a random directed spanning tree. *Advances in Applied Probability*, 36:19–42, 2004.
- [29] G. Bianchi. Performance analysis of the ieee 802.11 distributed coordination function. *IEEE Journal on Selected Areas in Communications*, 18:535–547, 2000.
- [30] P. Billingsley. *Convergence of Probability Measures*. Wiley Series in Probability and Mathematical Statistics. Wiley, 1968.
- [31] N. Bingham, C. Goldie, and J. Teugels. *Regular Variation*. Cambridge University Press, Cambridge, 1987.
- [32] B. Blaszczyszyn. Factorial moment expansion for stochastic systems. *Stoc. Proc. Appl.*, 56:321–335, 1995.
- [33] T. Bonald, S. Borst, and A. Proutiere. How mobility impacts the flow-level performance of wireless data systems. In *Proceedings of INFOCOM 04*, Hong Kong, March 2004.

- [34] T. Bonald and A. Proutiere. Downlink data channels: User performance and cell dimensioning. In *Proceedings of MOBICOM 03*, San Diego, September 2003.
- [35] C. Bordenave. Stability properties of data flows on a cdma network in macrodiversity. *INRIA RR-5257*, pages <http://www.inria.fr/rrrt/rr-5257.html>, 2004.
- [36] C. Bordenave. Navigation on a poisson point process. *submitted to Ann. Appl. Probab.*, 2006.
- [37] C. Bordenave. Spatial capacity of multiple access wireless networks. *to appear in IEEE Trans. Inf. Theo.*, 2006.
- [38] C. Bordenave. Stability of spatial networks. *Adv. Appl. Probab.*, 38-8, 2006.
- [39] C. Bordenave, D. Mac Donald, and A. Proutière. Random multi access algorithms, a mean field analysis. *43th Allerton Conference on Communication, Control and Computing*, 2005.
- [40] C. Bordenave, Y. Gousseau, and F. Roueff. The dead leaves model: a general tessellation modeling occlusion. *Advances in Applied Probability*, 38-1, 2006.
- [41] C. Bordenave and G.L. Torrisi. Monte carlo methods for sensitivity analysis of poisson-driven stochastic systems. *submitted to Stoch. Proc. Appl.*
- [42] A.A. Borovkov. *Ergodicity and Stability of Stochastic Processes*. Wiley Series in Probability and statistics. Wiley, 1994.
- [43] P. Brémaud. *Point Processes and Queues*. Springer, New York, 1981.
- [44] P. Brémaud. An insensitivity property of lundberg's estimate for delayed claims. *J. Appl. Prob.*, 37:914–917, 2000.
- [45] P. Brémaud and F.J. Vazquez-Abad. On the pathwise computation of derivatives with respect to the rate of a point process: The phantom rpa method. *Queueing Systems Theory Appl.*, 10:249–270, 1992.
- [46] G. Caire and S. Shamai. On the achievable throughput of a multi-antenna gaussian broadcast channel. *IEEE Trans. Inf. Theory*, 49:1691–1706, july 2003.
- [47] E. Coddington and N. Levinson. *Theory of Ordinary Differential Equations*. Mac Graw Hill Book, New York-Toronto-London, 1955.
- [48] M. Costa. Writing on dirty paper. *IEEE Trans. Inf. Theory*, 29:439–441, 1983.
- [49] T. Cover and J. Thomas. *Elements of information theory*. Wiley Series in Telecommunications. John Wiley & Sons Ltd., Chichester, 1991.
- [50] R. Cowan. Properties of ergodic random mosaic processes. *Math. Nachr.*, 97:89–102, 1980.
- [51] R. Cowan and A. K. L. Tsang. The falling leaf mosaic and its equilibrium properties. *Adv. App. Prob.*, 26:54–62, 1994.
- [52] R. Cowan and A. K. L. Tsang. Random mosaics with cells of general topology. Technical report, University of Hong Kong, 1995. <http://www.hku.hk/statistics/>.

- [53] J. Dai. On positive harris recurrence of multiclass: a unified approach via fluid limit models. *Annals of Applied Probability*, 5:49–77, 1995.
- [54] J. Dai and S Meyn. Stability and convergence of moments for multiclass queueing networks via fluid limit models. *IEEE Transactions on Automatic Control*, 40(11):1889–1904, 1995.
- [55] D.J. Daley and D. Vere-Jones. *An introduction to the Theory of Point Processes*. Springer Series in Statistics. Springer-Verlag, New-York, 1988.
- [56] L. Decreasefond. Perturbation analysis and malliavin calculus. *Ann. Appl. Prob.*, 8:496–523, 1998.
- [57] A. Dembo and O. Zeitouni. *Large Deviations Techniques and Applications*. Applications of Mathematics. Springer-Verlag, New-York, 1998.
- [58] R. Douc, G. Fort, E. Moulines, and P. Soulier. Practical drift conditions for subgeometric rates of convergence. *Ann. Appl. Prob.*, 3:1353–1377, 2004.
- [59] M. Draief and A. Ganesh. Routing in poisson small-world networks. *to appear in Jour. App. Probab.*, 2006.
- [60] A. Ephremides and B. Hajek. Information theory and communication networks: an unconsummated union. *IEEE Trans. on Inf. Theory*, 44:2416–2434, 1998.
- [61] S. Ethier and T. Kurtz. *Markov processes*. Wiley, New York, 1986.
- [62] W. Feller. *An Introduction to Probability Theory and its Applications, vol. II*. Wiley Series in Probability and Mathematical Statistics. John Wiley & Sons Ltd., second edition, 1971.
- [63] P. A. Ferrari, L. R. G. Fontes, and Xian-Yuan Wu. Two-dimensional poisson trees converge to the brownian web. <http://arXiv.org/abs/math/0304247>, 2003.
- [64] P.A. Ferrari, C. Landim, and H. Thorisson. Poisson trees, succession lines and coalescing random walks. *Annals de L'Institut Henry Poincaré Volume*, 40:141–152, 2004.
- [65] L.R.G. Fontes, M. Isopi, C.M.Newman, and K. Ravishankar. The brownian web : Characterization and convergence. *Annals of Probability*, 32:2857–2883, 2004.
- [66] S. Foss. Stochastic recursive sequences and their applications in queueing. *DSc Dissertation. Institute of Mathematics, Novosibirsk*, 1992.
- [67] S. Foss and A. Kovalevskii. A stability criterion via fluid limits and its application to a polling system. *Queueing Systems Theory Appl.*, 32(1-3):131–168, 1999.
- [68] M. Franceschetti and R. Meester. Navigation in small world networks, a scale-free continuum model. *preprint*, 2004.
- [69] A. Ganesh, A. Kermarrec, and L. Massoulie. Peer-to-peer membership management for gossip-based protocols, 2003.
- [70] A. Ganesh and F. Xue. On the connectivity and diameter of small-world networks. *MSR Technical Report*, 2005.
- [71] S. Gangopadhyay, R. Roy, and A. Sarkar. Random oriented trees : a model of drainage networks. *Annals of Applied Probability*, 14:1242–1266, 2004.

- [72] K. Gilhousen, I. Jacobs, R. Padovani, A. Viterbi, and L. Weaver. On the capacity of a cellular cdma system. *IEEE Trans. Veh. Technol.*, 40:303–312, 1991.
- [73] W. Gille. The set covariance of a dead leave model. *Adv. Appl. Prob.*, 34:11–20, 2002.
- [74] P. Glassermann. *Gradient Estimation via Perturbation Analysis*. Kluwer, Dordrecht, 1990.
- [75] K. Goebel and W. A. Kirk. *Topics in metric fixed point theory*, volume 28 of *Cambridge Studies in Advanced Mathematics*. Cambridge University Press, Cambridge, 1990.
- [76] C. Goffman and G. Pedrick. A proof of the homeomorphism of Lebesgue-Stieltjes measure with Lebesgue measure. *Proc. Amer. Math. Soc.*, 52:196–198, 1975.
- [77] A. Goldsmith, N. Jindal, and S. Vishwanath. Duality, achievable rates and sum-rate capacity of gaussian mimo broadcast channels. *IEEE Trans. Inf. Theory*, 49:2658–2668, Oct. 2003.
- [78] Y. Gousseau. Texture synthesis through level sets. In *2nd International Workshop on Texture Analysis and Synthesis*, pages 53–57, Copenhagen, 2002.
- [79] Y. Gousseau and F. Roueff. Modeling occlusion and scaling in natural images. Submitted, 2005.
- [80] C. Graham. Chaoticity on path space for a queueing network with selection of the shortest queue among several. *J. Appl. Prob.*, 37:198–211, 2000.
- [81] G. Grimmett. *Percolation*. Series of Comprehensive Studies in Mathematics. Springer, second edition, 1999.
- [82] M. Gudmundson. Correlation model for shadow fading in mobile radio systems. *Electronics Letters*, 27:2145–2146, 1991.
- [83] A. Gut. On the moments and limit distributions of some first passage times. *Ann. Probab.*, 2:277–308, 1974.
- [84] A. Gut. Convergence rates for probabilities of moderate deviations for sums of random variables with multidimensional indices. *Annals of Probability*, 8:298–313, 1980.
- [85] B. Hajek. Hitting-time and occupation-time bounds implied by drift analysis with applications. *Adv. Appl. Prob.*, 14:502–525, 1982.
- [86] B. Hajek and T. van Loon. Decentralized dynamic control of a multiaccess broadcast channel. *IEEE trans. on Automatic Control*, 27, 1982.
- [87] S. Hanly. Capacity and power control in spread spectrum macrodiversity networks. *Proceedings of of IEEE Trans. on Comm.*, 44:247–256, 1996.
- [88] S. Hanly. Congestion measures in ds-cdma networks. *Proceedings of of IEEE Trans. on Comm.*, 47:426–437, 1999.
- [89] S. Hanly and P. Whiting. Information-theoretic capacity of multi-receiver networks. *Telecommun. Syst.*, 1:1–42, 1993.
- [90] J. Håstad, T. Leighton, and B. Rogoff. Analysis of backoff protocols for multiple access channels. *SIAM J. Computing*, 25, 1996.

- [91] Y.C. Ho and X.R. Cao. Perturbation analysis and optimization of queueing networks. *J. Optim. Theory and Appl.*, 40:559–582, 1983.
- [92] R. Horn and C. Johnson. *Matrix analysis*. Cambridge University Press, Cambridge, 1985.
- [93] C. Howard and C. Newman. Geodesics and spanning trees for euclidean first-passage percolation. *Ann. Probab.*, 29:577–623, 2001.
- [94] Standard IEEE. Wireless lan medium access protocol and physical layer specifications. August 1999.
- [95] D. Jeulin. Morphological modeling of images by sequential random functions. *Signal Processing*, 16:403–431, 1989.
- [96] D. Jeulin. Dead leaves models: From space tessellation to random functions. In D. Jeulin, editor, *Advances in Theory and Applications of Random Sets*, pages 137–156, 1996.
- [97] D. Jeulin, I. Terol Villalobos, and A. Dubus. Morphological analysis of UO₂ powder using a dead leaves model. *Microscopy, Microanalysis, Microstructures*, 6:371–384, 1995.
- [98] O. Kallenberg. *Random measures*. Akademie-Verlag, Berlin, 1976.
- [99] M. Karray. 'factor'-mean formulas for hexagonal cdma networks with poisson traffic. *private communication*, 2003.
- [100] F.P. Kelly. Stochastic models of computer communication systems. *J. Royal Statistical Society, B*, 47, 1985.
- [101] W. S. Kendall. <http://www.warwick.ac.uk/statsdpt/staff/WSK/dead.html>. May 2004.
- [102] W. S. Kendall, J. Mecke, and D. Stoyan. *Stochastic Geometry and its Applications*. Wiley, Chichester, 2nd edition, 1995.
- [103] H. Kesten. Scaling relations for 2D-percolation. *Comm. Math. Phys.*, 109(1):109–156, 1987.
- [104] J.M. Kleinberg. The small-world phenomenon: an algorithmic perspective. *Proc. 32nd Annual ACM Symposium on the Theory of Computing*, pages 163–170, 2000.
- [105] C. Klüppelberg and T. Mikosch. Delay in claim settlement and ruin probability approximations. *Scand. Actuar. J.*, 2:154–168, 1995.
- [106] C. Klüppelberg and T. Mikosch. Explosive poisson shot noise processes with applications to risk reserves. *Bernoulli*, 1:125–147, 1995.
- [107] C. Klüppelberg, T. Mikosch, and A. Schärf. Regular variation in the mean and stable limits for poisson shot noise. *Bernoulli*, 9:467–496, 2003.
- [108] Y.B. Ko and N. Vaidya. Location-aided routing (lar) in mobile ad hoc networks. *Wireless Networks*, 6:307–321, 2000.
- [109] T. Kostantopoulos and S.J. Lin. Macroscopic models for long-range dependent network traffic. *Queueing Systems Theory Appl.*, 28:215–243, 1998.
- [110] E. Kranakis, H. Singh, and J. Urrutia. Compass routing on geometric networks. In *Proc. 11th Canadian Conference on Computational Geometry*, pages 51–54, Vancouver, August 1999.

- [111] P. L'Ecuyer. A unified version of the ipa, sf, and lr gradient estimation techniques. *Management Science*, 36:1364–1383, 1990.
- [112] A. Lee, D. Mumford, and J. Huang. Occlusion models for natural images: A statistical study of a scale invariant dead leaves model. *International J. of Computer Vision*, 41:35–59, 2001.
- [113] S. Lee. The central limit theorem for euclidian minimal spanning trees. *The Annals of Applied Probability*, 7:996–1020, 1997.
- [114] J. Liebeherr, M. Nahas, and W. Si. Application-layer multicasting with delaunay triangulation overlays. *IEEE Journal Selected Areas in Communications*, 20:1472–1488, 2002.
- [115] T. Lindvall. *Lectures on the Coupling Method*. Wiley, 1992.
- [116] C. Macci, G. Stabile, and G.L. Torrisi. Lundberg parameters for non standard risk processes. *To appear on Scand. Actuar. J.*, 2005.
- [117] M. Månsson and M. Rudemo. Random patterns of nonoverlapping convex grains. *Adv. App. Prob.*, 34(4):718–738, 2002.
- [118] G. Matheron. Modèle séquentiel de partition aléatoire. Technical report, CMM, 1968.
- [119] G. Matheron. *Random Sets and Integral Geometry*. Wiley, Chichester, 1975.
- [120] J. Mecke. Palm methods for stationary random mosaics. In R. V. Ambartzumian, editor, *Combinatorial Principles in Stochastic Geometry*, pages 124–132. Armenian Academy of Science Publishing House, 1980.
- [121] R. Meester and R. Roy. *Continuum percolation*, volume 119 of *Cambridge Tracts in Mathematics*. Cambridge University Press, Cambridge, 1996.
- [122] S. Meyn. Transience of multiclass queueing networks via fluid limit models. *Ann. Appl. Probab.*, 5(4):946–957, 1995.
- [123] S. Meyn and R. Tweedie. *Markov Chains and Stochastic Stability*. Springer-Verlag, London, 1993.
- [124] V. Mikhailov. Geometric analysis of stability of markov chains in r^n and its applications to throughput evaluation of the adaptive random multiple access algorithm. *Probl. Inform. Transm.*, 24:47–56, 1988.
- [125] J. Møller. Random tessellations in \mathbb{R}^d . *Adv. Appl. Prob.*, 21:37–73, 1989.
- [126] J. Møller and R.P. Waagepetersen. *Statistical Inference and Simulation for Spatial Point Processes*. Chapman and Hall/CRC, Boca Raton, 2003.
- [127] P. Morin. *Online routing in Geometric Graphs*. PhD thesis, Carleton University, School of Computer Science, 2001.
- [128] A. Okabe, B. Boots, K. Sugihara, and S. N. Chiu. *Spatial Tessellations: Concepts and Applications of Voronoi Diagrams*. Wiley, Chichester, 2nd edition, 2000.
- [129] M. Penrose. *Random Geometric Graphs*. Oxford Studies in Probability. Oxford Univeristy Press, Oxford, 2003.

- [130] M. Penrose and A. Wade. On the total length of the random minimal directed spanning tree. *preprint math.PR/0409201 from arxiv.org.*, 2004.
- [131] M. Penrose and A. Wade. Random minimal directed spanning trees and dickman-type distributions. *Advances in Applied Probability*, 36:691–714, 2004.
- [132] M. Penrose and J. Yukich. Limit theory for random sequential packing and deposition. *Annals of Applied Probability*, 12:272–301, 2001.
- [133] M. Penrose and J. Yukich. Weak laws of large numbers in geometric probability. *Annals of Applied Probability*, 13:277–303, 2003.
- [134] L. Pimentel. Asymptotics for first-passage times on delaunay triangulations. *ArXiv*, (math/0510605), 2005.
- [135] G. Plaxton, R. Rajaraman, and A. Richa. Accessing nearby copies of replicated objects in a distributed environment. In *ACM Symposium on Parallel Algorithms and Architectures*, pages 311–320, 1997.
- [136] M.I. Reiman and B. Simon. Open queueing systems in light traffic. *Oper. Res.*, 14:26–59, 1989.
- [137] M.I. Reiman and A. Weiss. Sensitivity analysis for simulations via likelihood ratios. *Oper. Res.*, 37:830–844, 1989.
- [138] W. Rhee. A matching problem and subadditive euclidean functionals. *Annals of Applied Probability*, 3:794–801, 1993.
- [139] L. Roberts. Aloha packet system with and without slots and capture. *Advanced research projects agency, Network information center.*, Tech. Rep.(ASS Note 8), 1972.
- [140] D. L. Ruderman. Origins of scaling in natural images. *Vision Research*, 37(23):3385–3398, 1997.
- [141] W. Rudin. *Real and complex Analysis*. McGraw-Hill Series in Higher Mathematics. McGraw-HillBook Co, second edition edition, 1974.
- [142] E. Seneta. *Non-negative matrices and Markov chains*. Springer Series in Statistics. Springer, 1981.
- [143] J. Serra. *Image Analysis and Mathematical Morphology*. Academic Press, London, 1982.
- [144] S. Smirnov and W. Werner. Critical exponents for two-dimensional percolation. *Math. Res. Lett.*, 8(5-6):729–744, 2001.
- [145] J. M. Steele. *Probability Theory and Combinatorial Optimization*, volume 69 of *NSF-CBMS*. SIAM, Philadelphia, 1997.
- [146] A. Stolyar. On stability of multiclass queueing networks: A relaxed sufficient condition via fluid processes. *Mark. Proc. Rel. Fields*, 1:491–512, 1995.
- [147] D. Stoyan. On generalized planar tessellation. *Math. Nachr.*, 128:215–219, 1986.
- [148] R. Suri and F.M. Zazanis. Perturbation analysis gives strongly consistent sensitivity estimates for the m/g/1 queues. *Management Science*, 34, 1988.

- [149] A.S. Sznitman. *Propagation of chaos, in Ecole d'été de probabilités de Saint-Flour XIX.* lecture notes in Maths 1464. Springer, Berlin, 1991.
- [150] M. Talagrand. Concentration of measure and isoperimetric inequalities in product spaces. *Publications Mathématiques de l'I.H.E.S.*, 81:73–205, 1995.
- [151] L. Tassiulas and A. Ephremides. Stability properties of constrained queueing systems and scheduling policies for maximum throughput in multihop radio networks. *IEEE Transactions on Automatic Control*, 37:1936–1948, 1992.
- [152] E. Thonnes and W. F. Kendall. Perfect simulation in stochastic geometry. *Pattern Recognition*, 32:1569–1586, 1999.
- [153] G.L. Torrisi. Simulating the ruin probability of risk processes with delay in claim settlement. *Stoc. Proc. Appl.*, 112:225–244, 2004.
- [154] B. Toth and W. Werner. The true self repelling motion. *Probability Theory and Related Fields*, 111:375–452, 1998.
- [155] M Vahidi-Asl and J. Wierman. First-passage percolation on the Voronoï tessellation and Delaunay triangulation. In *Random graphs '87 (Poznań, 1987)*, pages 341–359. Wiley, Chichester, 1990.
- [156] M. Vahidi-Asl and J. Wierman. A shape result for first-passage percolation on the Voronoï tessellation and Delaunay triangulation. In *Random graphs, Vol. 2 (Poznań, 1989)*, Wiley-Intersci. Publ., pages 247–262. Wiley, New York, 1992.
- [157] F.J. Vazquez-Abad. Rpa pathwise derivative estimation of ruin probabilities. *Insurance: Mathematics and Economics*, 26:269–288, 2000.
- [158] C. Villani. *Optimal transport, old and new.* Ecole d'été de probabilités de Saint-Flour -2005. to appear.
- [159] K. Wasserman, G. Michailidis, and N. Bambos. Differentiated processors scheduling on heterogeneous task flows. *Technical Report SU-Netlab-2001-12/1*, pages Engineering Library, Stanford University, 2001.
- [160] V. Weiss and M. Zähle. Geometric measures for random curved mosaics of \mathbf{R}^d . *Math. Nachr.*, 138:313–326, 1988.
- [161] J. Yukich. *Probability Theory of Classical Euclidean Optimization Problems.* Lecture Notes in Mathematics. Springer, 1998.
- [162] J. Zander. Distributed co-channel interference control in cellular radio systems. *IEEE Trans. Veh. Technol.*, 41:305–311, 1992.
- [163] J. Zander. Performance of optimum transmitter power control in cellular radio systems. *IEEE Trans. Veh. Technol.*, 41:57–62, 1992.
- [164] F.M. Zazanis. Analyticity of poisson-driven stochastic systems. *Adv. Appl. Prob.*, 24:532–541, 1992.
- [165] S. Zuev. Russo's formula for Poisson point fields and its applications. *Diskret. Mat.*, 4(3):149–160, 1992.