



# Modelling, Extraction and Description of Intrinsic Cues of High Resolution Satellite Images: Independent Component Analysis based approaches

PhD Thesis by Payam Birjandi

Director: Prof. Mihai Datcu

- High resolution satellite images contain a lot of information to be modelled.
- Natural landscapes can be modelled by texture-like features.
- Texture-like features give a global interpretation from the image but don't explain the details.
- Man-made or geometrical structures like urban area usually are modelled by local descriptors.
- Local descriptors are precise but complicated and time-consuming.
- We are looking for some descriptors suitable for geometrical structures but not complicated.

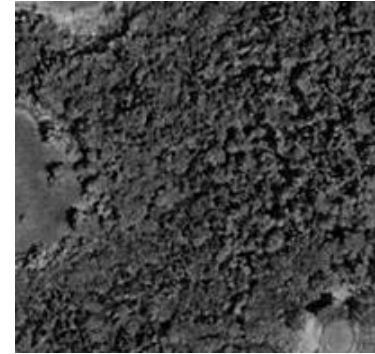

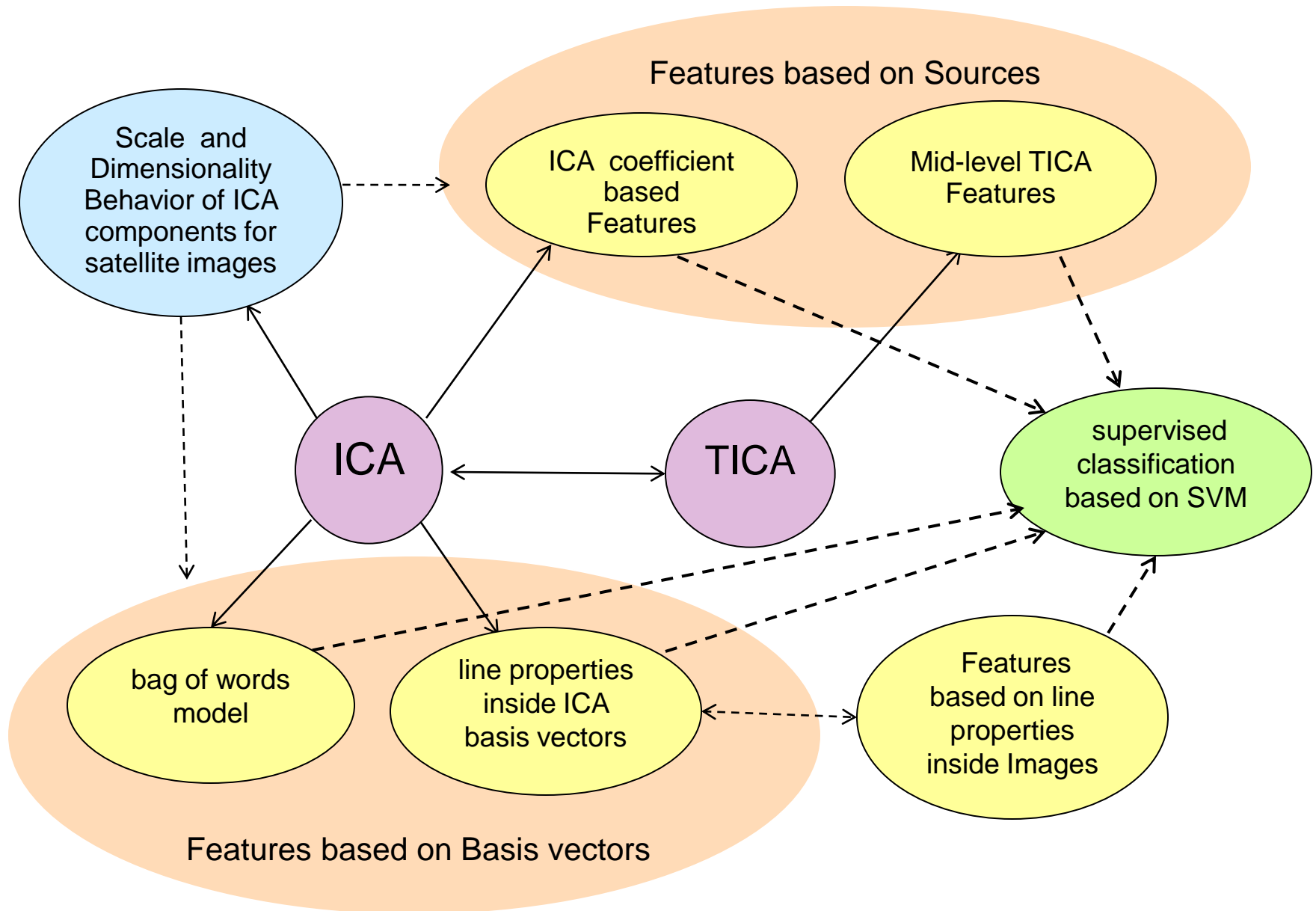

- Payam Birjandi et Mihai Datcu, (2010), "Multiscale and Dimensionality Behavior of ICA Components for Satellite Image Indexing", IEEE Geoscience and Remote Sensing Letters, vol. 7, n° 1, pp. 103 107.
- Payam Birjandi et Mihai Datcu, (2009), Bag of words model using ICA components for high resolution satellite image characterization, "SPIE", Berlin, germany, vol. 7477.
- Payam Birjandi et Mihai Datcu, (2009), ICA based visual words for describing under meter high resolution satellite images., "IEEE IGARSS 2009".
- Payam Birjandi et Mihai Datcu, "Mid-level Topographic ICA Features for Satellite Image Patches: A Descriptor for Geometrical Structure", Submitted for IEEE JSTAR

- Principles of Independent Component Analysis
- Scale and Dimensionality Behavior of ICA components for satellite images
- Feature extraction from ICA sources
- Middle level Topographic ICA features
- Feature extraction from ICA basis vectors: Bag of Words model
- Feature extraction from ICA basis vectors: Line and gradient properties
- Features based on line properties inside Images
- supervised classification based on SVM
- Conclusions and Perspectives

- **Principles of Independent Component Analysis**
- Scale and Dimensionality Behavior of ICA components for satellite images
- Feature extraction from ICA sources
- Middle level Topographic ICA features
- Feature extraction from ICA basis vectors: Bag of Words model
- Feature extraction from ICA basis vectors: Line and gradient properties
- Features based on line properties inside Images
- supervised classification based on SVM
- Conclusions and Perspectives

- The general framework of ICA was introduced by Héroult and Jutten (1985)<sup>1</sup> but was most clearly stated by Pierre Comon (1994)<sup>2</sup> and developed by Hyvarinen, Karhunen and Oja (2001)<sup>3</sup>.
- General ICA Applications:
  - Cocktail party problem
  - Data compression
  - Feature extraction
- Application of ICA on image data:
  - Natural image modeling
  - Face detector
  - Hand write detection
  - Remote sensing and satellite images

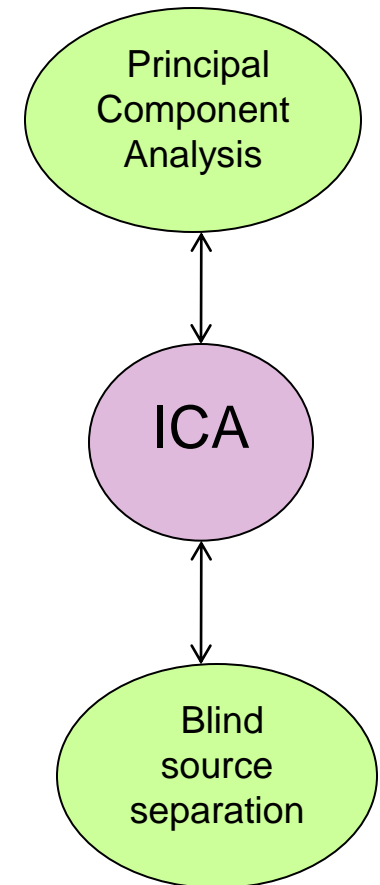

- 1- ANS, B., J. HERAULT, and C. JUTTEN, 1985. Adaptive neural architectures: Detection of primitives. In: Proceedings of COGNITIVA'85. pp. 593–597.
- 2- COMON, Pierre, 1994. Independent Component Analysis, A New Concept? Signal Processing, 36(3), 287–314.
- 3- HYVARINEN, Aapo, Juha KARHUNEN, and Erkki OJA, 2001. Independent Component Analysis. Adaptive and Learning Systems for Signal Processing, Communications, and Control. New York: Wiley.

- Our observed signal ( $x_{obs}$ ) as a random vector is supposed to be produced as a linear combination of some independent random variables called sources  $s_1, s_2, \dots, s_n$  :

$$x_{obs}(1) = a_1 s_1(1) + a_2 s_2(1) + \dots + a_n s_n(1)$$

$$x_{obs}(2) = a_1 s_1(2) + a_2 s_2(2) + \dots + a_n s_n(2)$$

⋮

- $a_1, a_2, \dots, a_n$  : **Basis vectors** (with the same dimensions as  $x_{obs}$  )  
 $s_1(k), \dots, s_n(k)$  : **Sources**
- Estimation of **basis vectors** such that the **sources** will be statistically as **independent** as possible is referred to as Independent Component Analysis.
- It is equivalent to estimate the mixing matrix,  $A$  , ( $x = As$  ), or the separating matrix,  $W$  , ( $s = Wx$  )



## Pre-processing

- Centering:  $E\left\{\tilde{x}_{obs}\right\} = \mathbf{0}$
- Whitening:  $x_{obs} \longrightarrow \tilde{x}_{obs} : E\left\{\tilde{x}_{obs}\tilde{x}_{obs}^T\right\} = \mathbf{I}$ 
  - Whitening implies obtaining **Principal Components** of data
  - Principal Component Analysis  $\longrightarrow$  Uncorrelated components
  - Independent Component Analysis  $\longrightarrow$  Independent components

## Learning

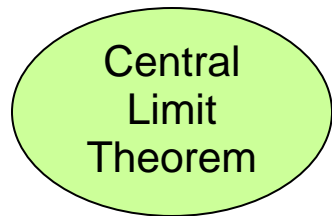

Linear combination of some independent random variables has a distribution that is closer to Gaussian than each of original random variables

- Definition:  $y = w^T x_{obs} = w^T A s = z^T s$
- Searching for  $w^T$  that maximizes the non-Gaussianity of random variable  $y$

- Sub-meter satellite images contain a variety of natural or man-made scenes.
- Descriptors are defined for **Contextual patches** with the size of 200\*200 pixels
- **Micro patches** are used in the procedure of feature extraction

*Original satellite image*



*Contextual image patch*



*Micro image patch*



Feature extraction methods based on ICA

- Some of ICA basis vectors include only a small change in their corner. They are resulted from learning patches with similar properties.

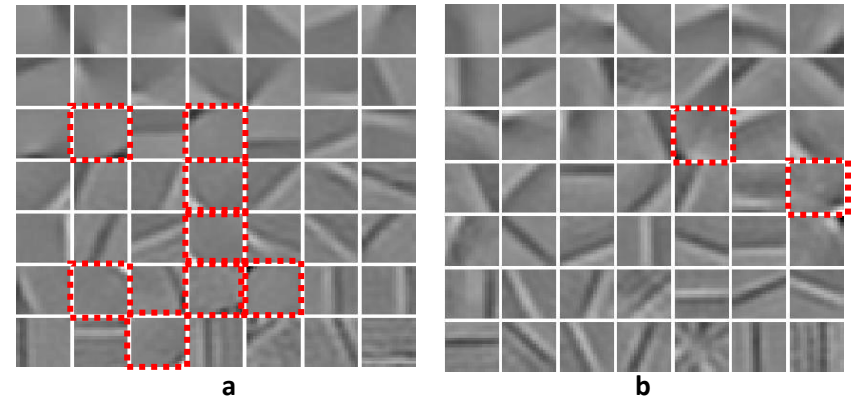

- The Idea is to use a set of Gabor filters to choose the learning patches that contain the most changes in their central parts.

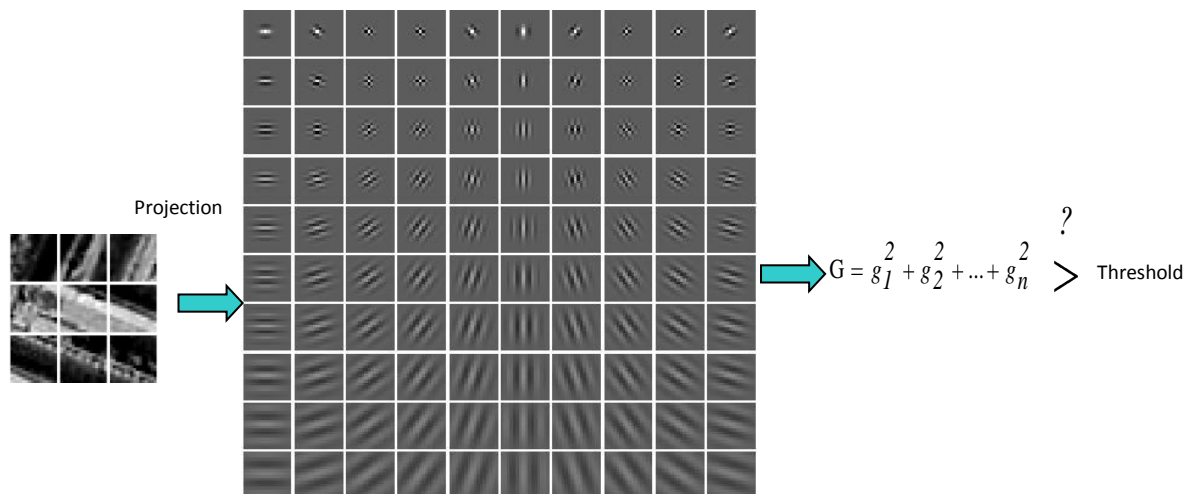

- Principles of Independent Component Analysis
- **Scale and Dimensionality Behavior of ICA components for satellite images**
- Feature extraction From ICA sources
- Middle level Topographic ICA features
- Feature extraction from ICA basis vectors: Bag of Words model
- Feature extraction from ICA basis vectors: Line and gradient properties
- Features based on line properties inside Images
- supervised classification based on SVM
- Conclusions and Perspectives

# Scale and Dimensionality Behavior of ICA components for satellite images

- The problem is that we can not use an ICA system for the contextual image patches because of their large size. In addition, the number of basis vectors is usually reduced in an ICA system.
- Scale size (size of basis vectors) and dimensionality (number of basis vectors) of ICA system which is used for satellite image characterization are important to be studied.



$$\begin{array}{l} \begin{array}{c} \xrightarrow{m} \\ \begin{array}{|c|} \hline \text{Patch} \\ \hline \end{array} \\ \xleftarrow{m} \end{array} \\ \\ \begin{array}{c} \begin{array}{|c|} \hline \text{Patch} \\ \hline \end{array} \end{array} \end{array} \quad \begin{array}{l} \text{\textit{n} components} \\ \hline = S_1 \begin{array}{|c|} \hline a_1 \\ \hline \end{array} + S_2 \begin{array}{|c|} \hline a_2 \\ \hline \end{array} + \dots + S_n \begin{array}{|c|} \hline a_n \\ \hline \end{array} \\ \\ = S'_1 \begin{array}{|c|} \hline a'_1 \\ \hline \end{array} + S'_2 \begin{array}{|c|} \hline a'_2 \\ \hline \end{array} + \dots + S'_m \begin{array}{|c|} \hline a'_{n'} \\ \hline \end{array} \end{array}$$

- Reduction factor : 
$$r = \frac{n}{m^2}$$

- Error of reconstruction as a criterion for efficiency of ICA system:

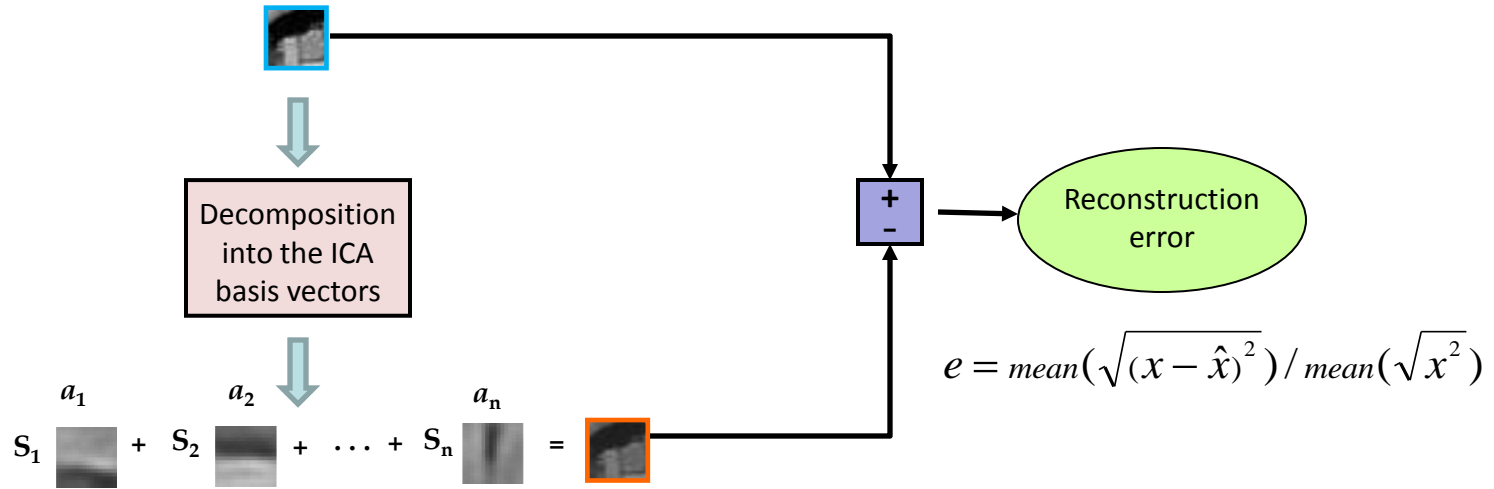

- When we use more ICA basis vector ( a higher reduction factor) , an ICA system can represent the image more efficiently, so the reconstruction error reduces:

<i>Number of components</i>	4	6	8	12	16	32	63
<i>Reduction factor</i>	0.0625	0.0938	0.125	0.1875	0.25	0.5	0.9844
<i>Reconstruction error (%)</i>	36.1	26.9	23.1	20.2	17.6	12.7	1.1

- Simultaneously, when we use more ICA basis vectors ( a higher reduction factor) , we have more computational problems and need more time:

<i>Number of components</i>	4	6	8	12	16	32	63
<i>Reduction factor</i>	0.0625	0.0938	0.125	0.1875	0.25	0.5	0.9844
<i>Time (sec)</i>	1.8	2.7	3.7	6.2	11.8	24.2	56.3

- We try to minimize a Cost Function that increases with both of computation time (t) and reconstruction error (e) :  $CF(r) = kt(r) + (1-k)e(r)$  ,  $(0 \leq k \leq 1)$

optimum reduction factor: 0.1

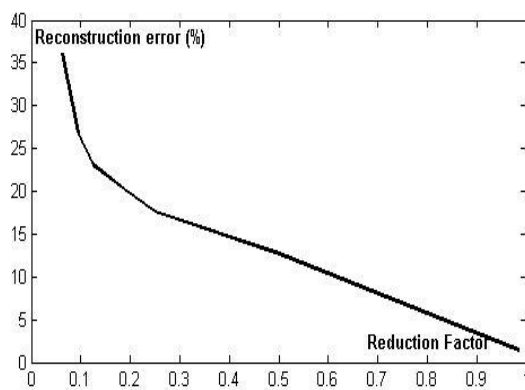

(a)

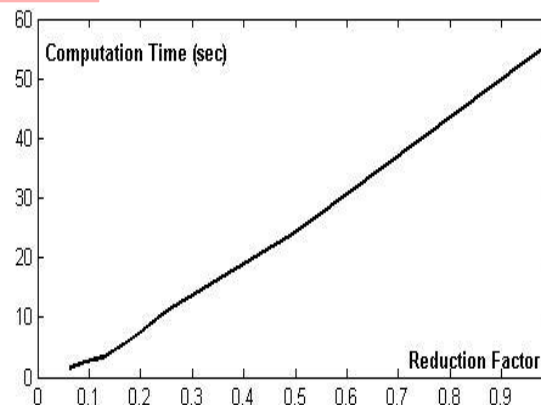

(b)

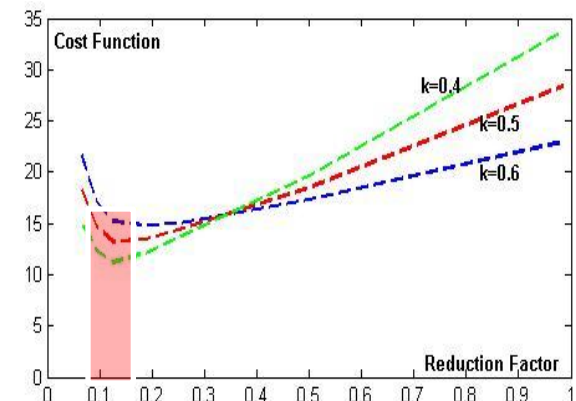

(c)

# Scale size of ICA basis vectors

- When the size of basis vectors is getting larger, we could see more various forms of edges, lines and other structures.

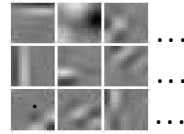

Size of basis vectors = 16\*16

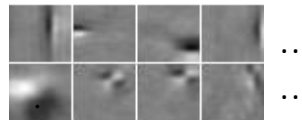

Size of basis vectors = 32\*32

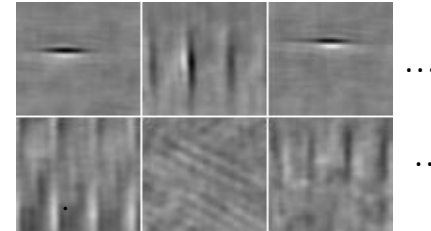

Size of basis vectors = 64\*64

- We define a cost function but as a function of the size of basis vectors:

$$CF(m) = kt(m) + (1 - k)e(m), \quad (0 \leq k \leq 1)$$

optimum size of basis vector: 16\*16

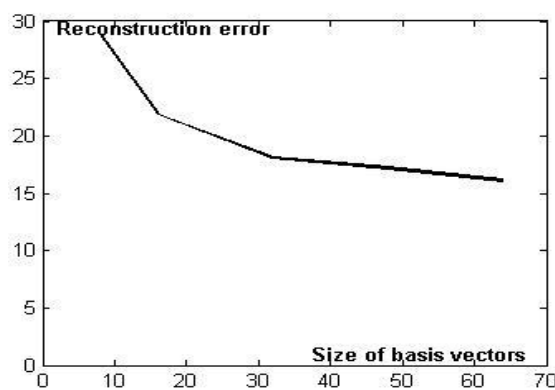

(a)

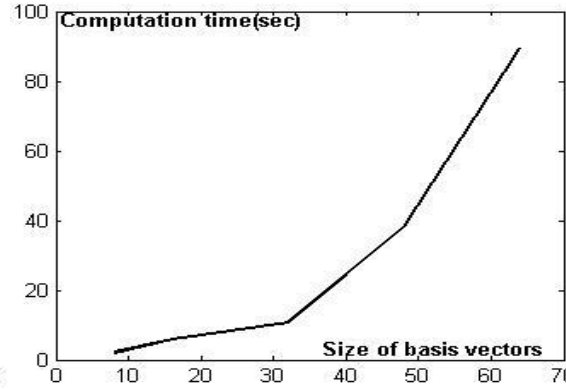

(b)

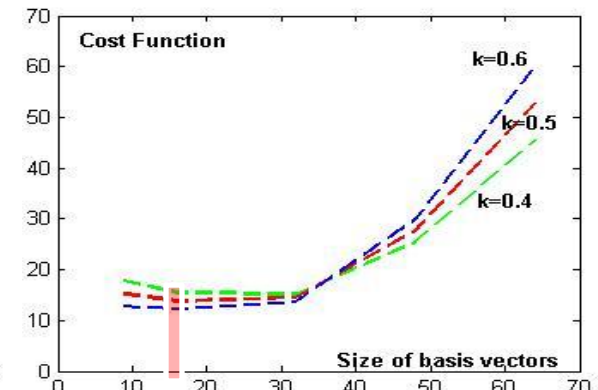

(c)



- Principles of Independent Component Analysis
- Scale and Dimensionality Behavior of ICA components for satellite images
- **Feature extraction from ICA sources**
- Middle level Topographic ICA features
- Feature extraction from ICA basis vectors: Bag of Words model
- Feature extraction from ICA basis vectors: Line and gradient properties
- Features based on line properties inside Images
- supervised classification based on SVM
- Conclusions and Perspectives

# Defining features for contextual patches

- To extract features from ICA sources, we need a set of basis vector. We apply ICA learning procedure on all of learning micro patches gathered from all classes.
- We sample a sufficient number of micro patches and decompose them onto the set of basis vectors and for each we obtain a set of 25 sources.
- Applying the root mean square over samples of a specific source we obtain the corresponding feature.

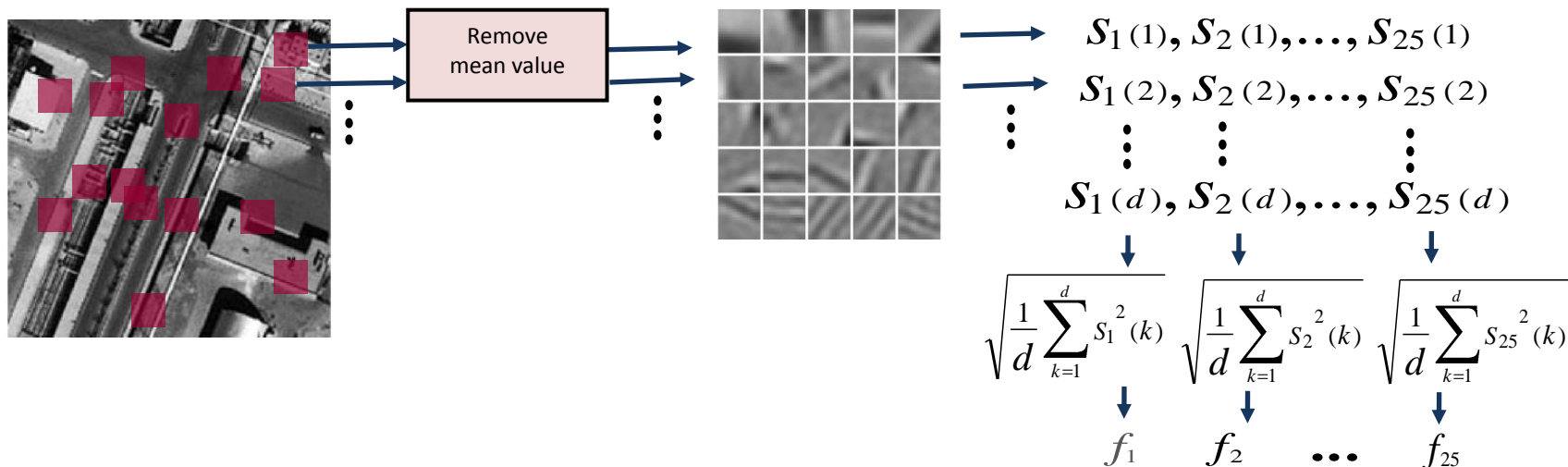

# Test set of contextual image patches

- A set of 800 samples of contextual image patches in 8 classes of natural and man-made landscapes is provided.
- We perform an initial evaluation of features based on clustering of the test set.

Class1: Factory



Class2: Farm

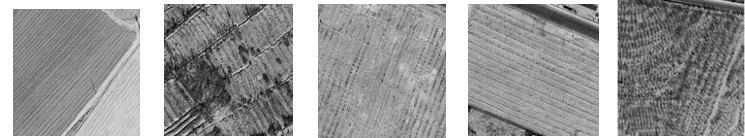

Class3: Village



Class4: City-1



Class5: Forest

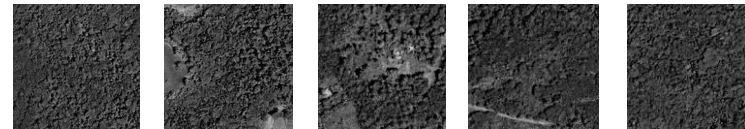

Class6: City-2



Class7: Town



Class8: Sea

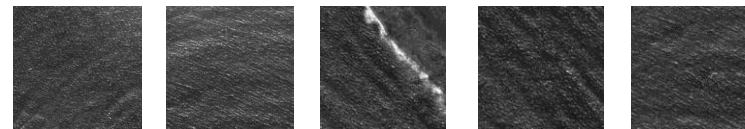

# Resulted features and clustering

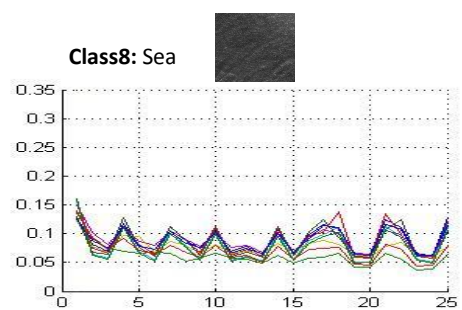
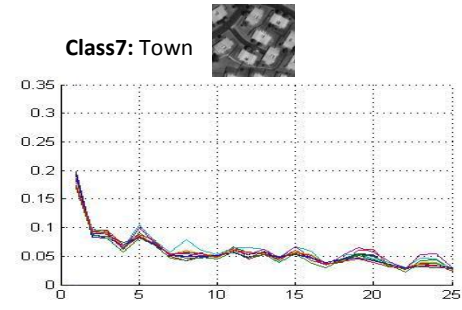
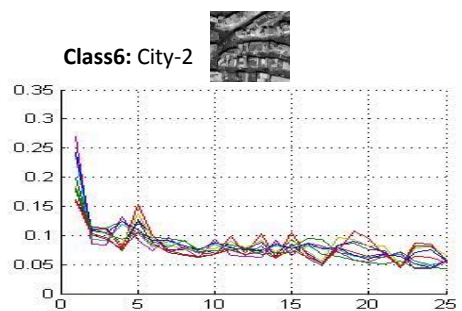
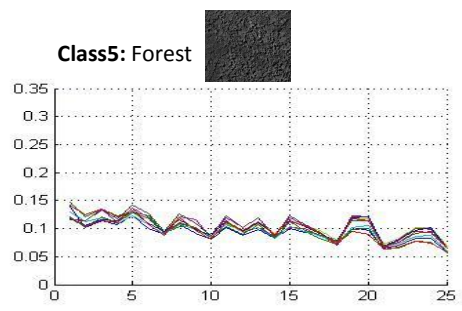
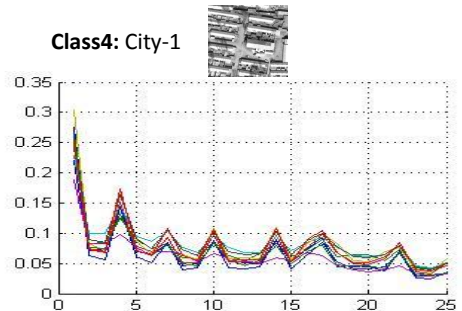
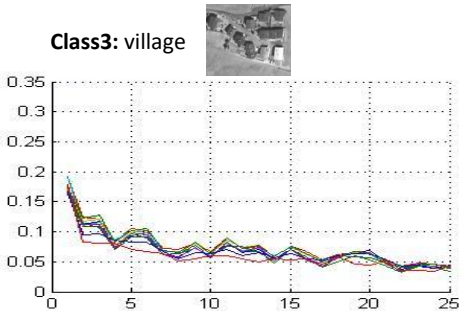
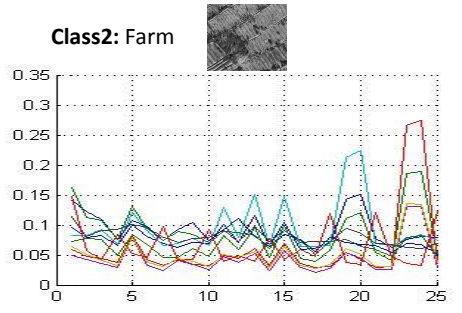
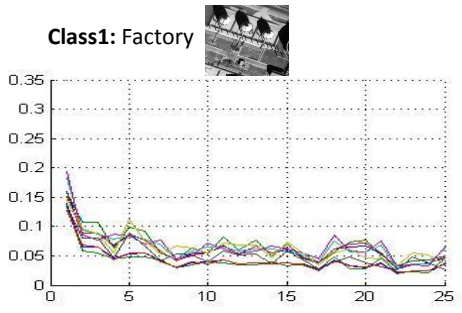

■ Results of clustering:

Clusters	Class1 Factory	Class2 Farm	Class3 Village	Class4 City-1	Class5 Forest	Class6 City-2	Class7 Town	Class8 Sea
1	67.7	8.9	6.7	3.3	4.4	8.9	0	1.1
2	4.4	48.9	4.4	0	4.4	4.4	7.8	14.4
3	5.5	6.7	73.3	2.2	2.2	2.2	7.8	0
4	6.7	1.1	0	74.4	4.4	7.8	4.4	8.9
5	0	11.1	1.1	4.4	74.4	0	2.2	8.9
6	8.9	6.7	6.7	2.2	1.1	71.1	5.5	0
7	6.7	4.4	7.8	5.5	2.2	0	72.2	0
8	0	12.2	0	7.8	6.7	5.5	0	66.7

- Normally used for the cases that the objective is to separate two classes.
- The idea is to choose the most important basis vectors from each class and bring them together to make a new set of basis vectors.
- Initially two sets of basis vectors for each class are provided.
- We project micro patches from each class into each of basis vectors sets and calculate the probabilities of squared sources ( $P(s_i^2)$ ) in every case.

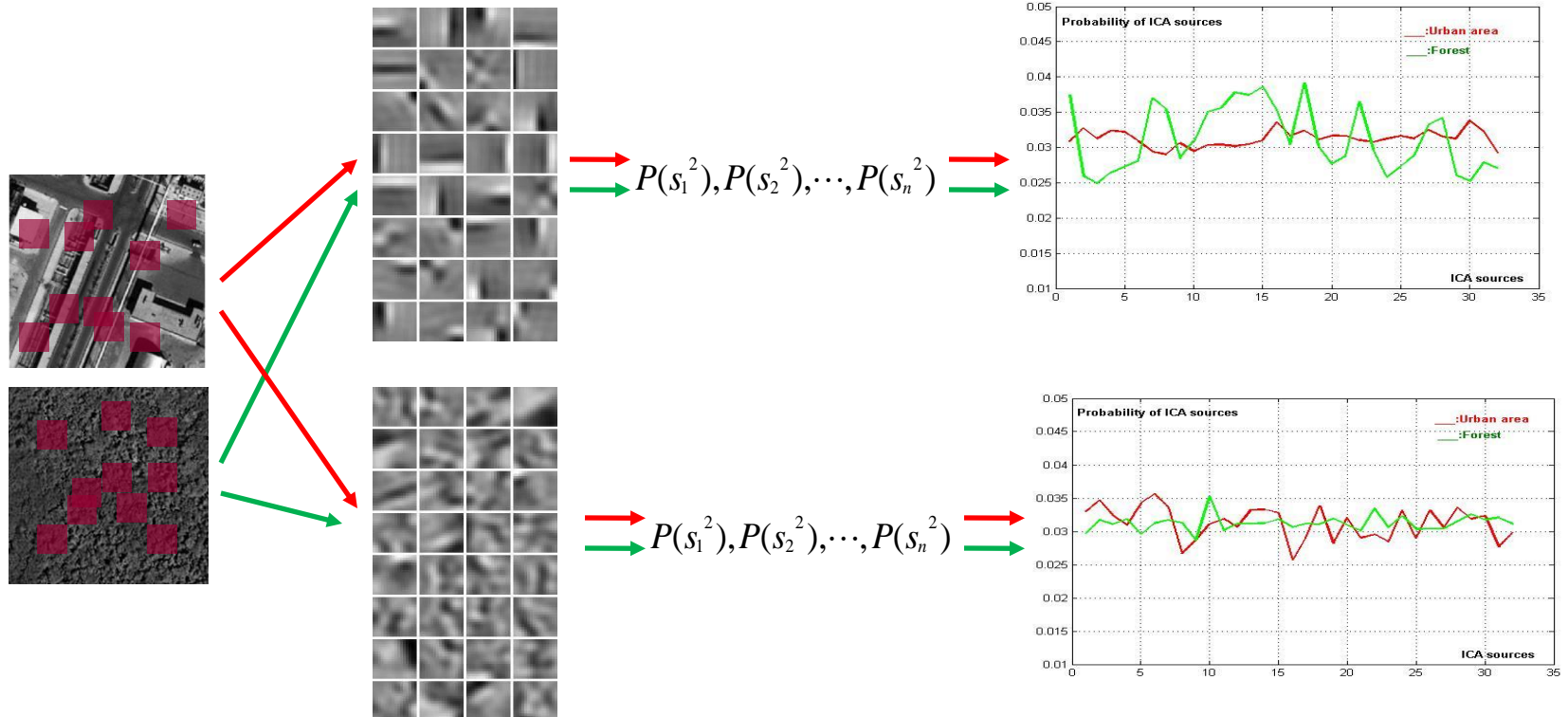

- We select a basis vector from each class if the corresponding probability,  $P(s_i^2)$  is obviously higher than  $P(s_i^1)$  calculated for other class.
- The new basis vector set is obtained by bringing the most basis vectors from two classes together:

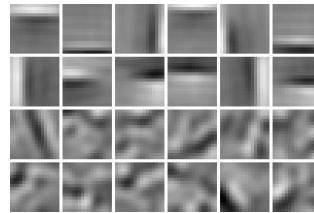

- Results of clustering in the percent format for separating the urban area from the forest. (a) Result of ordinary set of basis vectors. (b) Results of the new set of basis vectors combined from the most important basis vectors of two classes.

(a)

Clusters	Class4 City-1	Class5 Forest
1	<b>84.4</b>	18.9
2	15.6	<b>81.1</b>

(b)

Clusters	Class4 City-1	Class5 Forest
1	<b>90</b>	15.6
2	10	<b>84.4</b>

- Principles of Independent Component Analysis
- Scale and Dimensionality Behavior of ICA components for satellite images
- Feature extraction from ICA sources
- **Middle level Topographic ICA features**
- Feature extraction from ICA basis vectors: Bag of Words model
- Feature extraction from ICA basis vectors: Line and gradient properties
- Features based on line properties inside Images
- supervised classification based on SVM
- Conclusions and Perspectives

- In ordinary ICA, the components are assumed to be completely independent, and they do not have any relationship, order or priority.
- In Topographic ICA, the dependency between 2 components is a function of their distance in a specific topographic representation.
- The dependency between 2 components comes from correlation of their variances.
- To define our topography, a neighbourhood function for each components is necessary:

$$nb(i, j) = \begin{cases} 1 & \text{if } d(i, j) \leq L \\ 0 & \text{if } d(i, j) > L \end{cases}$$

- To generate one variance related to a component, we use the linear combination of a set of “higher-order” independent variables (  $u_1, u_2, \dots, u_n$  ) that are in its neighbourhood. Then a nonlinear function (  $\Phi$  ) gives the variance:

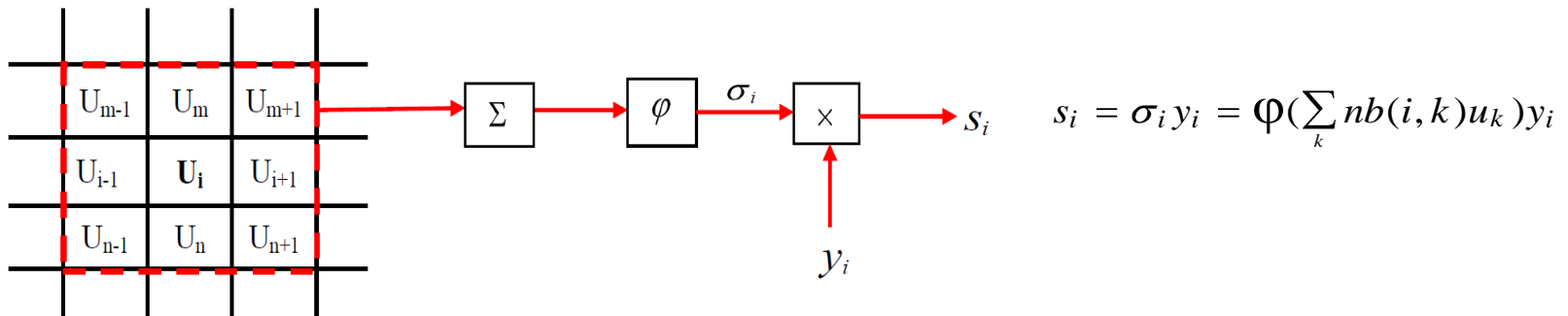



- (a) ICA system with 100 basis vectors. The order of basis vectors is not important but we sort them based on their mean frequencies.
- (b) TICA system with 100 basis vectors and a topography of 10 components by 10 components and also a neighborhood of 5 components by 5 components.

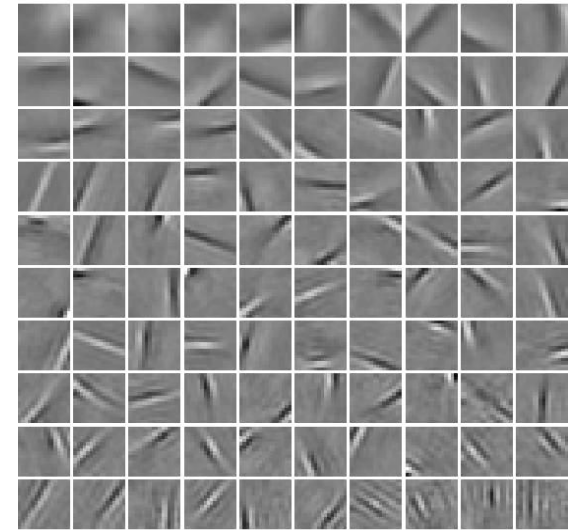

a

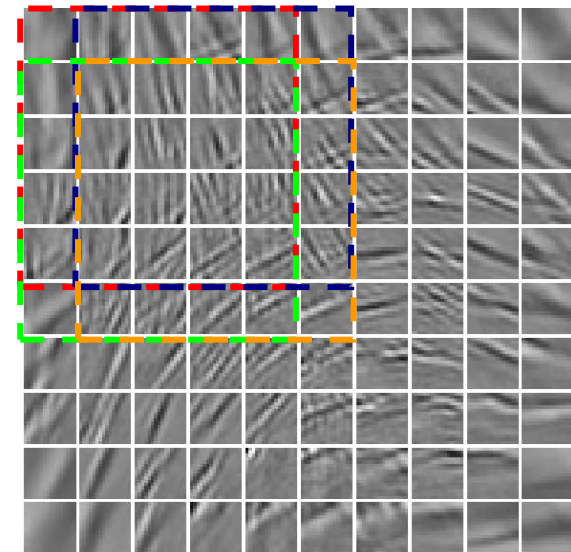

b

- The most important advantage of TICA is that we can use a large number of components but we extract a few number of features .
- Using a set of 100 TICA basis vectors 100 low level features are provided, then using dependencies among the components, we extract 9 middle level TICA features:

Contextual Patches

Descriptor Production

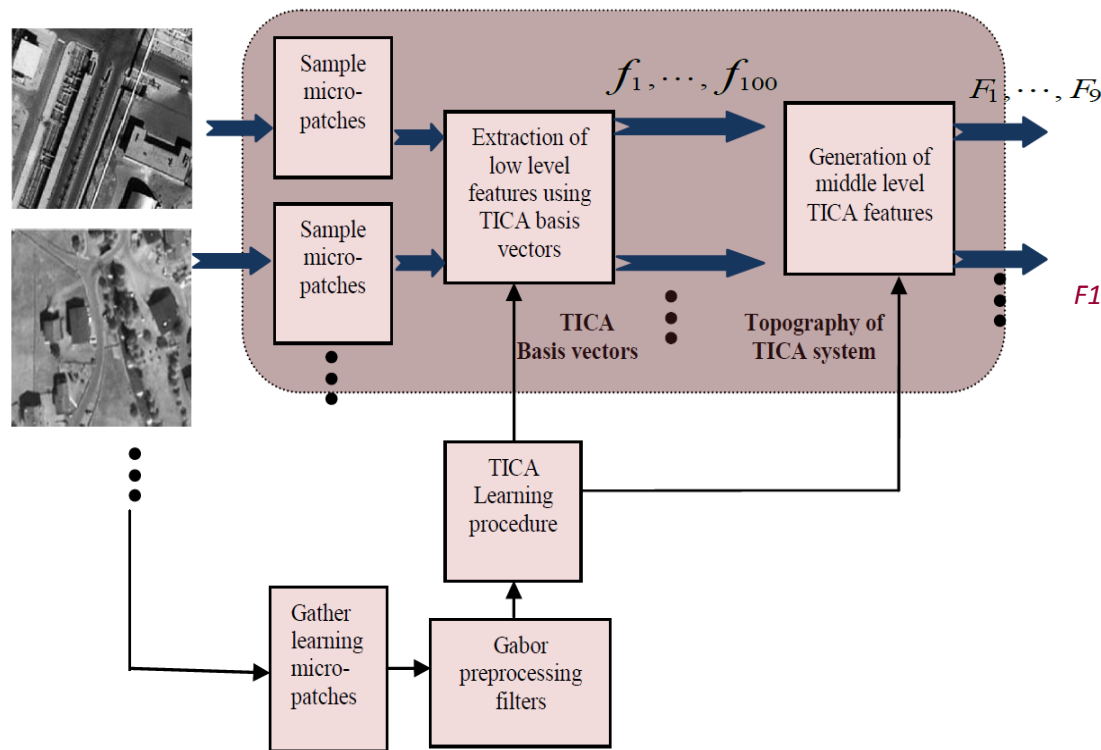

$$F_m = \frac{1}{25} \sum_{n=1}^{25} f_n$$

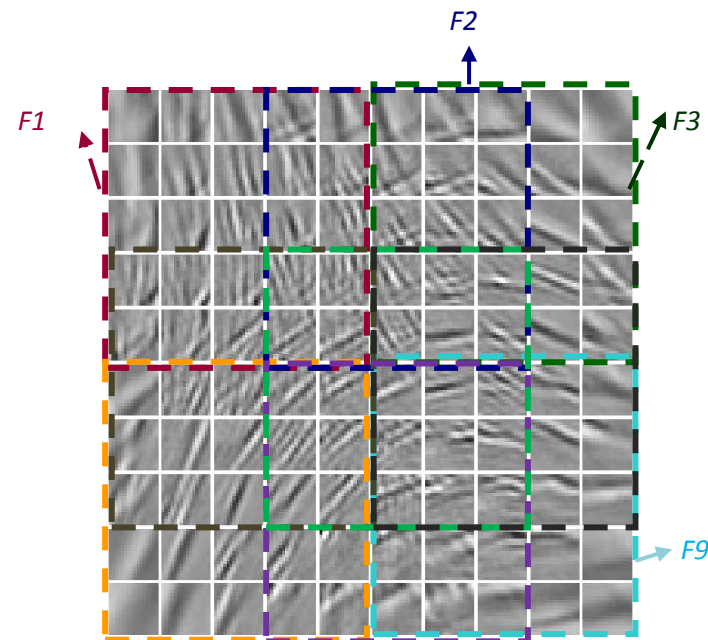

# Resulted features and clustering

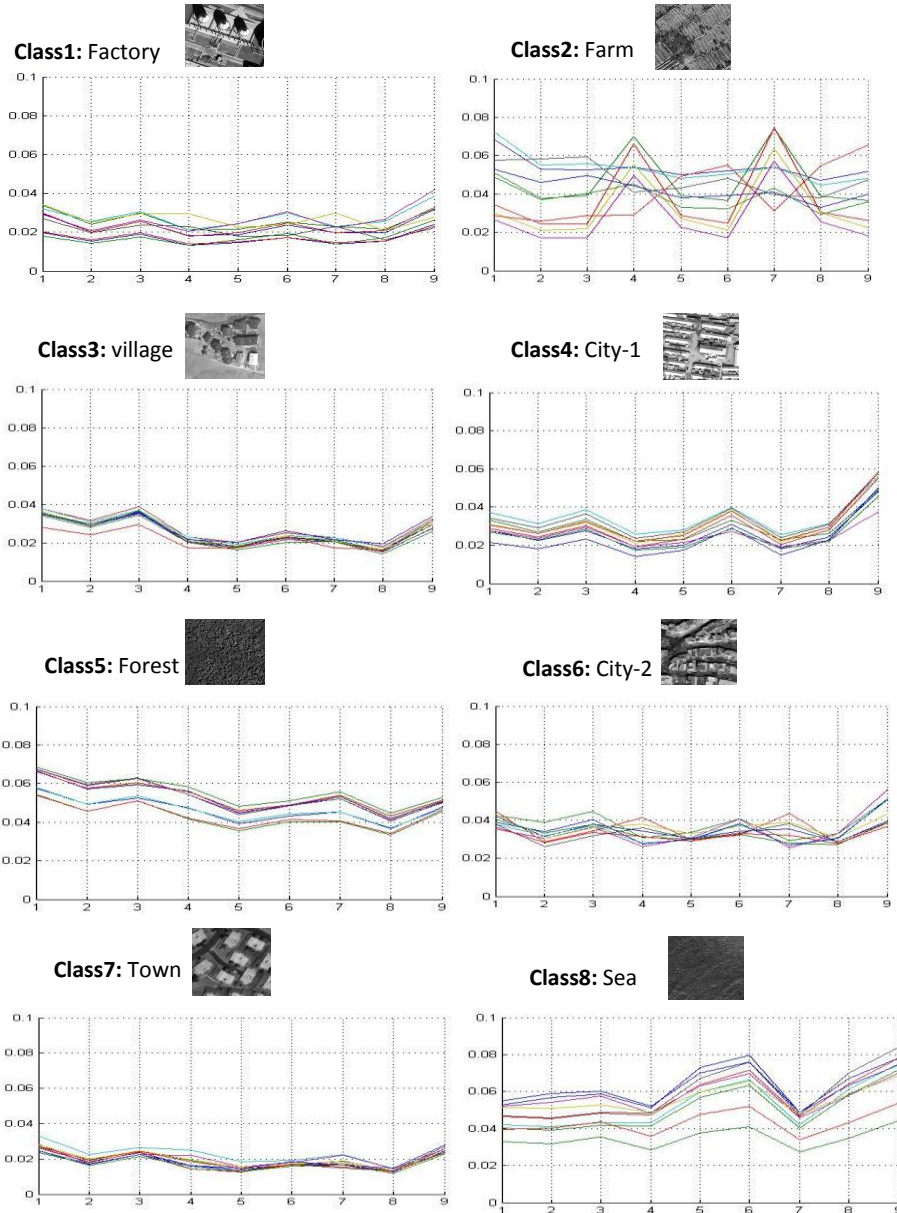

■ Results of clustering:

Clusters	Class1 Factory	Class2 Farm	Class3 Village	Class4 City-1	Class5 Forest	Class6 City-2	Class7 Town	Class8 Sea
1	81.1	3.3	3.3	2.2	1.1	1.1	3.3	1.1
2	1.1	74.4	2.2	1.1	8.9	2.2	0	7.8
3	3.3	0	83.3	3.3	1.1	3.3	1.1	1.1
4	5.5	0	3.3	86.7	0	3.3	3.3	1.1
5	0	11.1	1.1	1.1	81.1	1.1	1.1	5.5
6	4.4	1.1	1.1	3.3	0	86.7	2.2	1.1
7	3.3	1.1	4.4	2.2	1.1	1.1	88.9	0
8	1.1	8.9	1.1	0	6.7	1.1	0	82.2

- Principles of Independent Component Analysis
- Scale and Dimensionality Behavior of ICA components for satellite images
- Feature extraction from ICA sources
- Middle level Topographic ICA features
- **Feature extraction from ICA basis vectors: Bag of Words model**
- Feature extraction from ICA basis vectors: Line and gradient properties
- Features based on line properties inside Images
- supervised classification based on SVM
- Conclusions and Perspectives

- There are two points of view for feature extraction using ICA from image data. The usual approach is to use the ICA coefficients (ICA sources).
- The other point of view is to use the ICA basis vectors which are corresponding to every image.
- We are going is to find basic characteristics of the ICA basis vectors extracted from each contextual image patch.

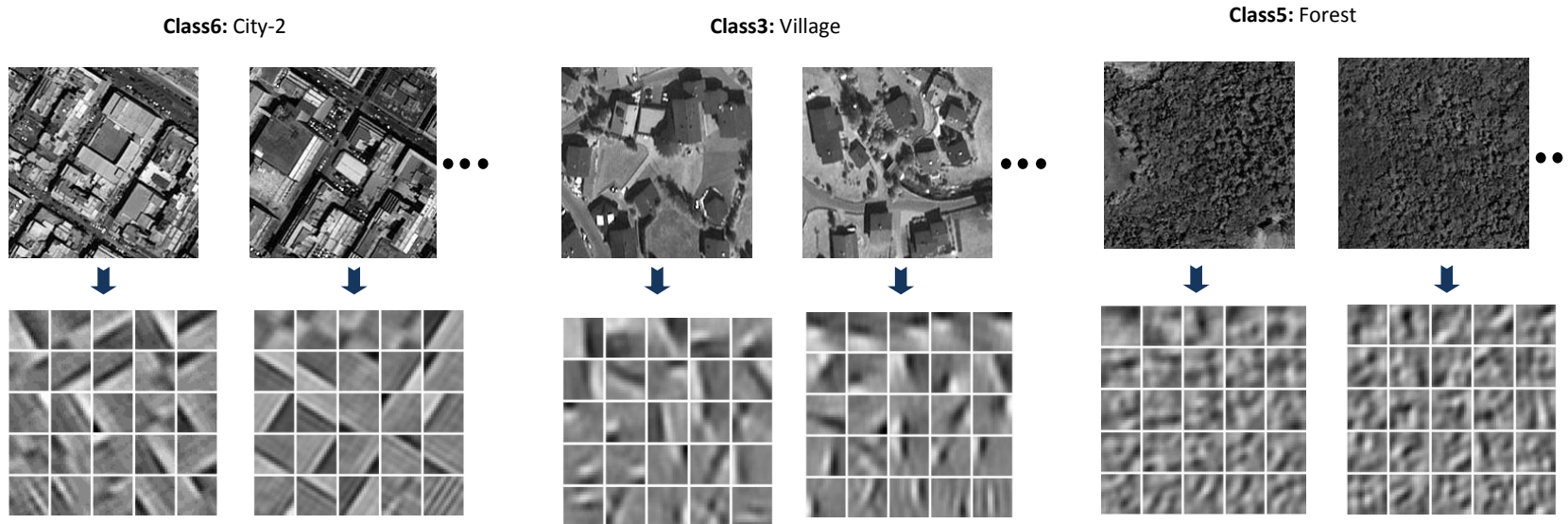

# Bag of words model

- In text retrieval approaches, the Bag of Words (BoW) is a model for representing the documents as a set of dictionary words in which the arrangement of words is not important.
- For using the BoW idea to characterize the images, the basic problem is to define an analogy between texts and images.
- Document  $\rightarrow$  Contextual patches
- Words  $\rightarrow$  ICA basis vectors
- Dictionary  $\rightarrow$  Two ways are proposed
- Labeling  $\rightarrow$  Finding the most similar dictionary word for each basis vector.
- Histogram  $\rightarrow$  repeats of dictionary words for each document

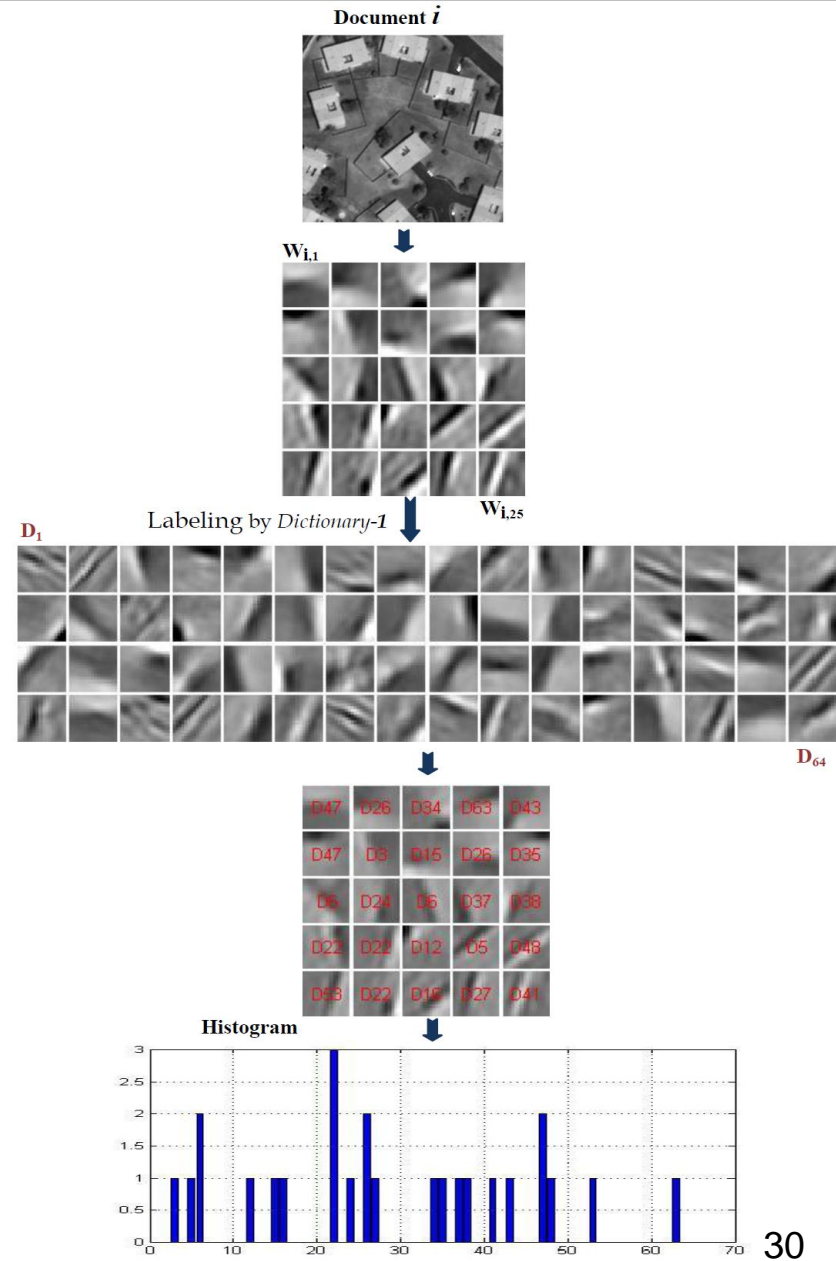

- Dictionary1 is produced through a clustering on the basis vectors of contextual patches.
- Dictionary2 is produced through obtaining basis vectors for each class.
- The normal approach is to label each document word by only one dictionary word which is the most similar to the document word:

$$C(w_1, w_2) = \frac{|w_1 w_2|}{|w_1| |w_2|}$$

- Many of the features are zero because usually the number of document words is less than the number of dictionary words.
- The idea is to measure the total similarity between one dictionary word with all of document words.

$$f_{i,k} = \underset{j}{\text{mean}}(C(D_k, w_{i,j}))$$

- The advantage of this new approach is that all dictionary words participate in defining a feature.

# Resulted features and clustering (Dictionary1)

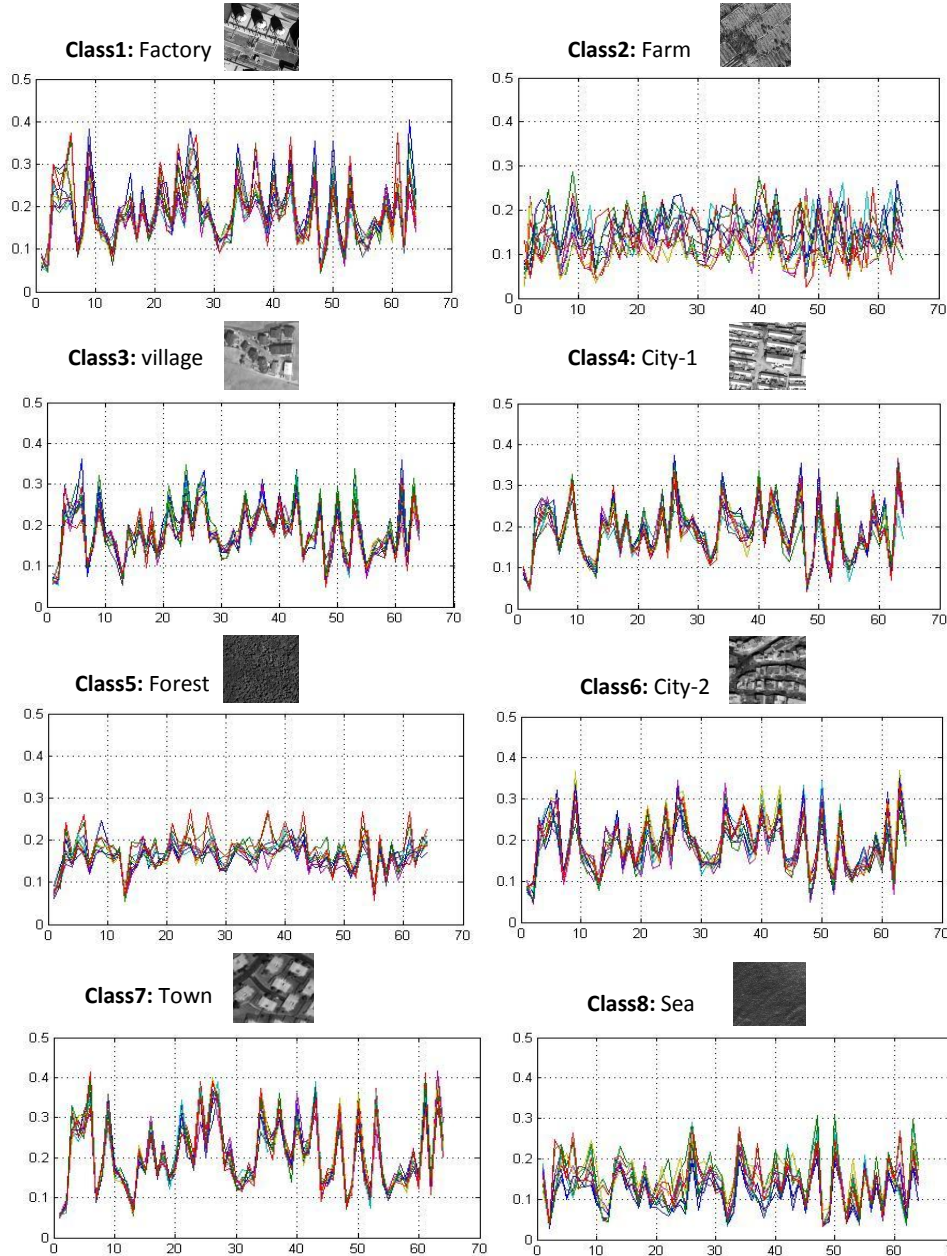

■ Result of clustering:

Clusters	Class1 Factory	Class2 Farm	Class3 Village	Class4 City-1	Class5 Forest	Class6 City-2	Class7 Town	Class8 Sea
1	71.1	6.7	2.2	3.3	4.4	7.7	3.3	1.1
2	4.4	55.6	10	1.1	5.5	3.3	10	6.7
3	5.5	6.7	71.1	2.2	4.4	4.4	4.4	5.5
4	3.3	1.1	2.2	77.8	1.1	6.6	2.2	3.3
5	5.5	10	3.3	2.2	76.7	1.1	2.2	2.2
6	5.5	7.8	4.4	3.3	3.3	72.2	4.4	2.2
7	4.4	6.7	5.5	4.4	1.1	2.2	72.2	0
8	0	5.5	1.1	5.5	3.3	2.2	1.1	78.9



# Resulted features and clustering (Dictionary2)

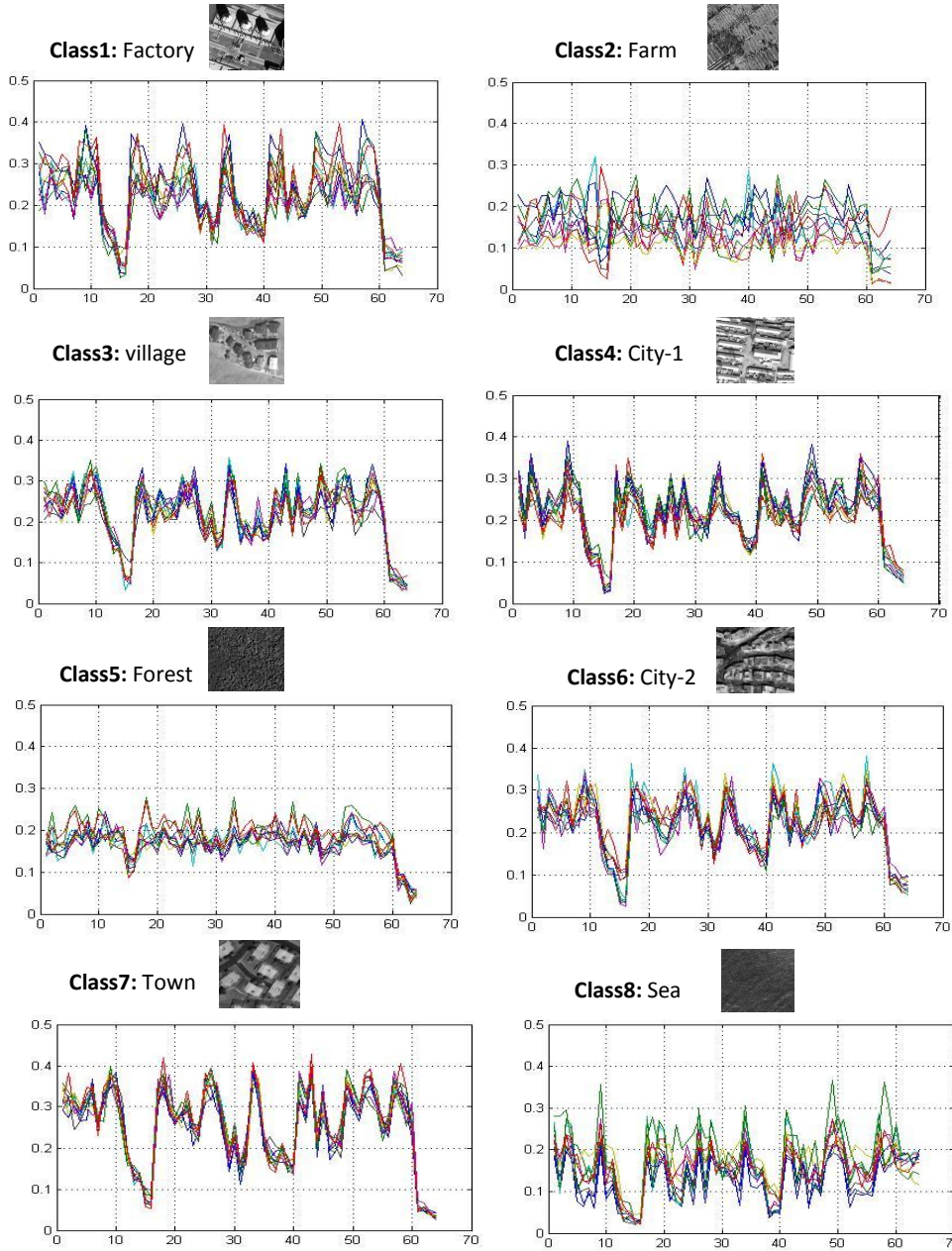

■ Result of clustering:

Clusters	Class1 Factory	Class2 Farm	Class3 Village	Class4 City-1	Class5 Forest	Class6 City-2	Class7 Town	Class8 Sea
1	74.4	5.5	2.2	3.3	2.2	5.5	3.3	0
2	2.2	58.9	7.8	1.1	4.4	4.4	5.5	8.9
3	3.3	7.8	75.6	2.2	5.5	3.3	3.3	3.3
4	5.5	1.1	1.1	81.1	1.1	4.4	4.4	5.5
5	3.3	5.5	3.3	0	78.9	0	2.2	2.2
6	5.5	3.3	4.4	3.3	2.2	77.8	4.2	2.2
7	4.4	7.8	5.5	4.4	1.1	2.2	75.6	1.1
8	1.1	10	0	4.4	4.4	2.2	1.1	76.7

- Principles of Independent Component Analysis
- Scale and Dimensionality Behavior of ICA components for satellite images
- Feature extraction from ICA sources
- Middle level Topographic ICA features
- Feature extraction from ICA basis vectors: Bag of Words model
- **Feature extraction from ICA basis vectors: Line and gradient properties**
- Features based on line properties inside Images
- supervised classification based on SVM
- Conclusions and Perspectives

# Lines and gradient as basic characteristics of basis vectors

- Basis vectors could be modelled by their lines.
- The basis vectors of right image contain some lines which are mostly long and intense from gradient point of view.
- The basis vectors of left image have some lines which are shorter and weaker from gradient point of view.
- Moreover, the distributions of lines angles in two sets of basis vectors are different.
- This can be an idea for extracting features from the basis vectors of one image.

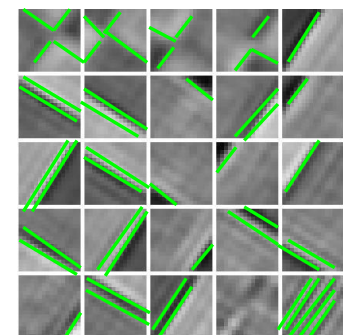
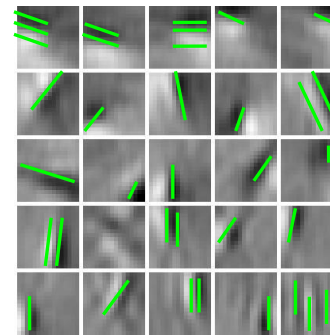
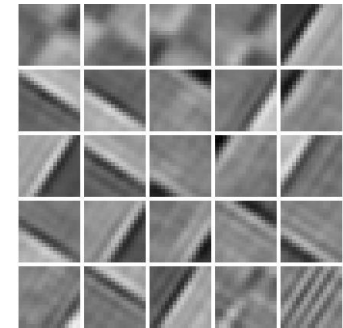
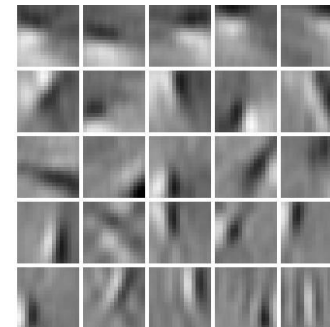

# Edge detection and line approximation

- For edge detection we use Sobel operator and thresholding and edge thinning step is applied to have one pixel thick edges
- We introduce a line approximation method which is fast and precise with respect to some classical methods such as Hough.
- This method is based on finding the 3-pixel lines.
- Then we enlarge each line from two sides until its direction doesn't change significantly .
- At last we extract some features from the lines properties

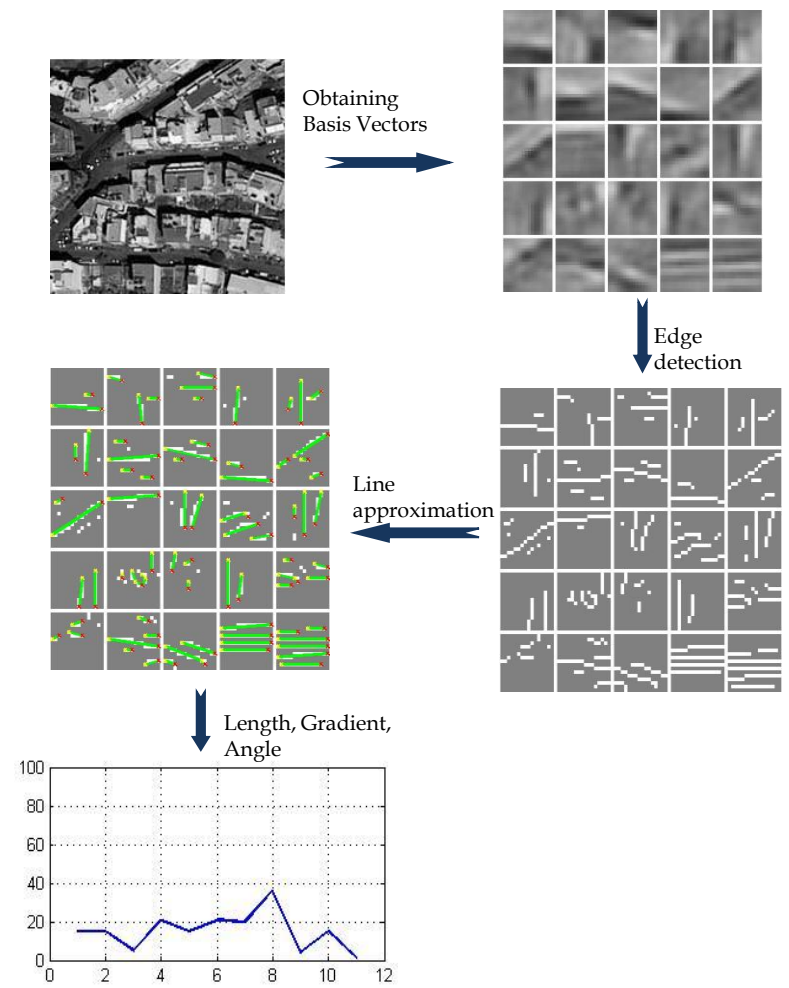

# Feature extraction from lines properties

- The length, the average of gradient magnitudes and the angle of a line is considered as its most important characteristics.
- For each line, we put each of its characteristics (length, average of gradient magnitude and angle) into the corresponding bin.
- The number of elements in each bin could be considered as a feature of our contextual patch.

Feature	1	2	3	4	5	6	7
<b>Description</b>	<i>Short,</i>	<i>Medium,</i>	<i>Long,</i>	<i>Very Long</i>	<i>Weak</i>	<i>Strong</i>	<i>Very Strong</i>
<b>Interval</b>	$4 \leq L \leq 6$ , $7 \leq L \leq 10$ ,		$11 \leq L \leq 13$	$14 \leq L$ ,	$ G  < 0.11$	$0.11 \leq  G  < 0.14$	$ G  \geq 0.14$

  

Feature	8	9	10	11
<b>Description</b>	<i>Horizontal</i>	<i>Oblique1</i>	<i>Vertical</i>	<i>Oblique2</i>
<b>Interval</b>	$0^\circ \pm 22.5^\circ$	$45^\circ \pm 22.5^\circ$	$90^\circ \pm 22.5^\circ$	$135^\circ \pm 22.5^\circ$

# Resulted features and clustering

**Class1: Factory** 

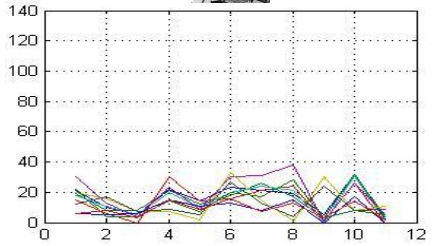

**Class2: Farm** 

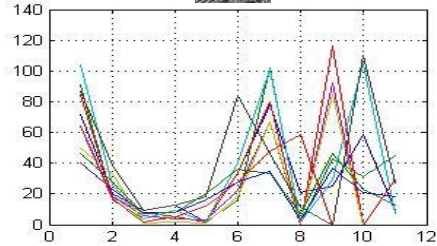

**Class3: village** 

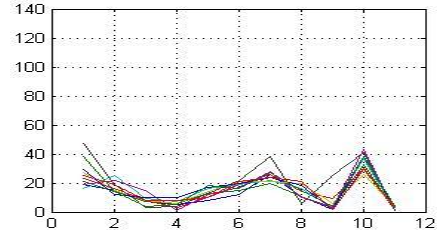

**Class4: City-1** 

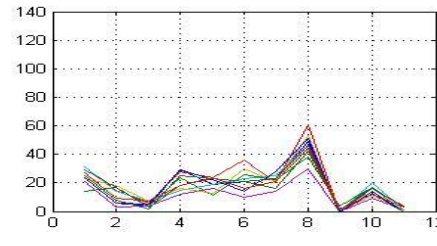

**Class5: Forest** 

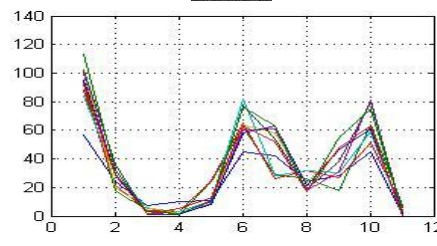

**Class6: City-2** 

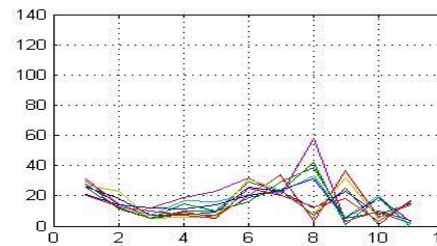

**Class7: Town** 

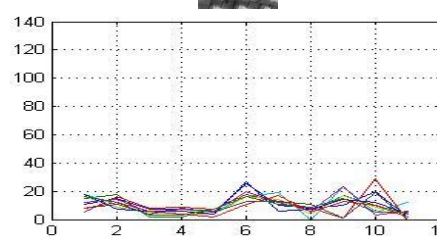

**Class8: Sea** 

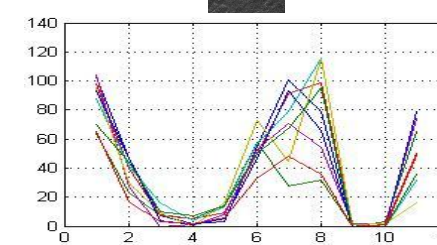

■ Result of clustering:

Clusters	Class1 Factory	Class2 Farm	Class3 Village	Class4 City-1	Class5 Forest	Class6 City-2	Class7 Town	Class8 Sea
1	<b>83.3</b>	3.3	5.5	2.2	1.1	1.1	2.2	0
2	0	<b>73.3</b>	0	1.1	10	1.1	0	8.9
3	3.3	0	<b>85.6</b>	3.3	0	3.3	4.4	0
4	6.6	1.1	3.3	<b>84.4</b>	0	5.5	3.3	0
5	0	12.2	1.1	0	<b>81.1</b>	0	0	7.8
6	4.4	1.1	2.2	5.5	0	<b>87.8</b>	3.3	0
7	2.2	0	2.2	3.3	0	1.1	<b>86.7</b>	0
8	0	8	0	0	7	0	0	<b>83.3</b>

- Principles of Independent Component Analysis
- Scale and Dimensionality Behavior of ICA components for satellite images
- Feature extraction from ICA sources
- Middle level Topographic ICA features
- Feature extraction from ICA basis vectors: Bag of Words model
- Feature extraction from ICA basis vectors: Line and gradient properties
- **Features based on line properties inside Images**
  - supervised classification based on SVM
- Conclusions and Perspectives

# Line segments inside image as basis components

- ICA basis vectors provide a space to represent the images. They can be modeled by their lines.



$$\text{Patch} = S_1 a_1 + S_2 a_2 + \dots + S_n a_n$$

- The idea is to detect lines directly in the contextual image patch and extract features from their characteristics.



$$f_1^*(\text{short line}) + \dots + f_k^*(\text{long line}) + \dots + f_j^*(\text{weak line}) + \dots + f_i^*(\text{strong line}) + \dots + f_m^*(\text{horizontal line}) + \dots + f_n^*(\text{vertical line}) + \dots$$



# Feature extraction from lines approximated inside the image

- Without performing an ICA procedure We directly do other steps such as edge detection and line approximation.
- Finally, for each line, we consider a narrow segment around it and put each of its characteristics (length, average of gradient magnitude and angle) into the corresponding bin.
- The intervals of bins are different from previous case:

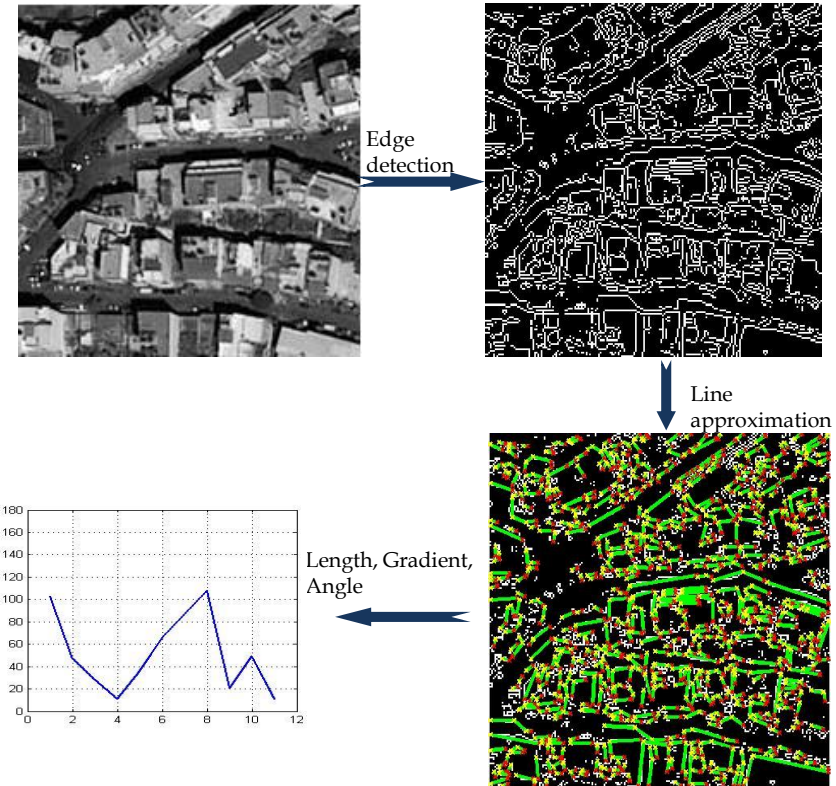

Feature	1	2	3	4	5	6	7
Description	<i>Short,</i>	<i>Medium,</i>	<i>Long,</i>	<i>Very Long</i>	<i>Weak</i>	<i>Strong</i>	<i>Very Strong</i>
Interval	$8 \leq L \leq 12$	$13 \leq L \leq 15$	$16 \leq L \leq 20$	$21 \leq L$	$ G  < 42$	$42 \leq  G  < 60$	$ G  \geq 60$

Feature	8	9	10	11
Description	<i>Horizontal</i>	<i>Oblique1</i>	<i>Vertical</i>	<i>Oblique2</i>
Interval	$0^\circ \pm 22.5^\circ$	$45^\circ \pm 22.5^\circ$	$90^\circ \pm 22.5^\circ$	$135^\circ \pm 22.5^\circ$

# Resulted features and clustering

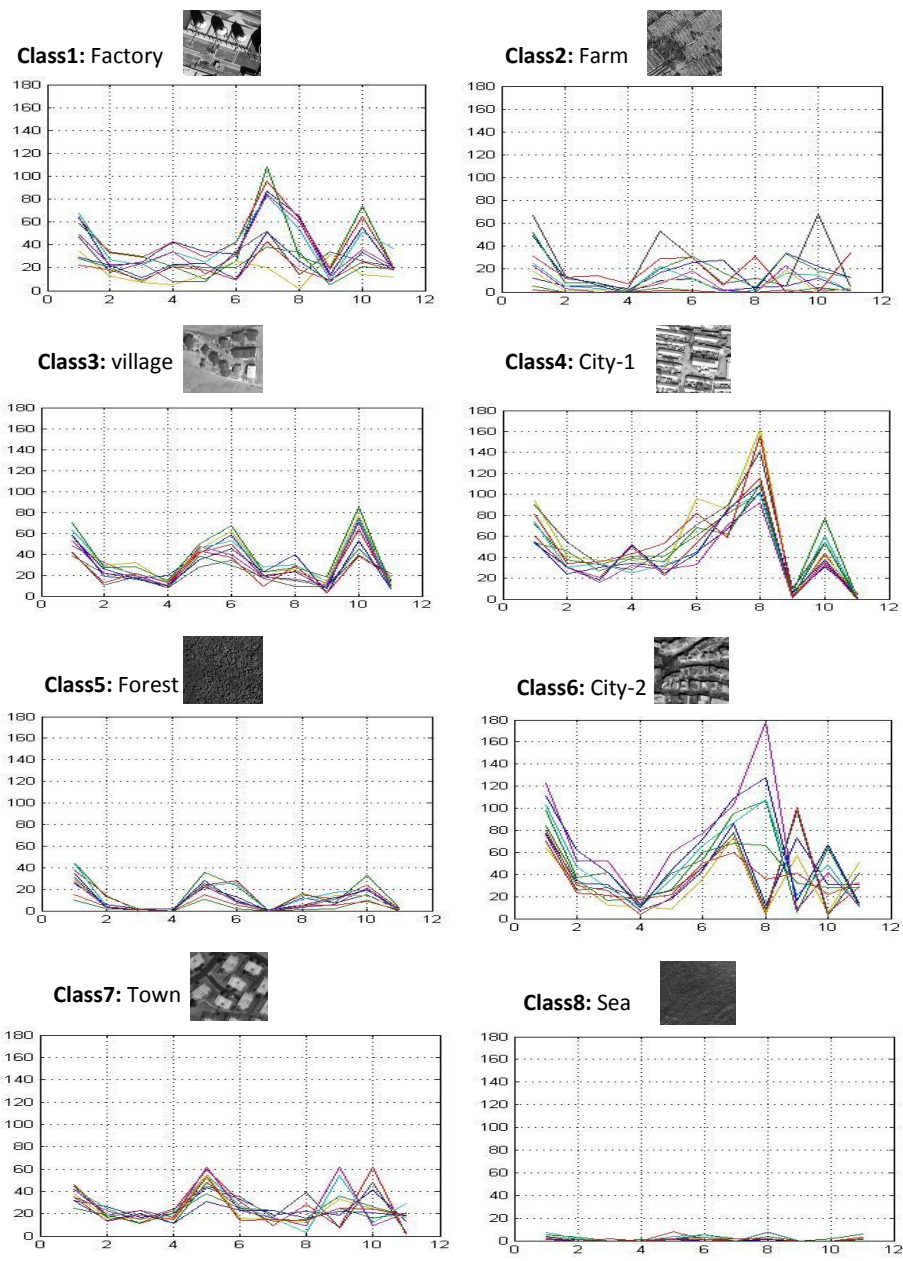

■ Result of clustering:

Clusters	Class1 Factory	Class2 Farm	Class3 Village	Class4 City-1	Class5 Forest	Class6 City-2	Class7 Town	Class8 Sea
1	84.4	2.2	3.3	2.2	1.1	4.4	2.2	0
2	0	71.1	0	1.1	11.1	0	0	10
3	4.4	0	88.9	2.2	0	3.3	3.3	0
4	5.5	1.1	1.1	86.7	0	4.4	4.4	0
5	0	13.3	1.1	0	80	0	0	6.7
6	3.3	1.1	0	5.5	0	86.7	2.2	0
7	2.2	0	5.5	2.2	0	1.1	87.8	0
8	0	11.1	0	0	6.7	0	0	83.3

- Principles of Independent Component Analysis
- Scale and Dimensionality Behavior of ICA components for satellite images
- Feature extraction from ICA sources
- Middle level Topographic ICA features
- Feature extraction from ICA basis vectors: Bag of Words model
- Feature extraction from ICA basis vectors: Line and gradient properties
- Features based on line properties inside Images
- **Supervised classification based on SVM**
- Conclusions and Perspectives

- To evaluate our proposed descriptor a usual way is to examine them through a classifier.
- Supervised classifiers let us to detect samples corresponding to a desired class.
- The idea of Super Vector Machine (SVM) is to fit a separating hyperplane between two classes such that the samples that are located at the boundaries of two classes will be as far as possible.

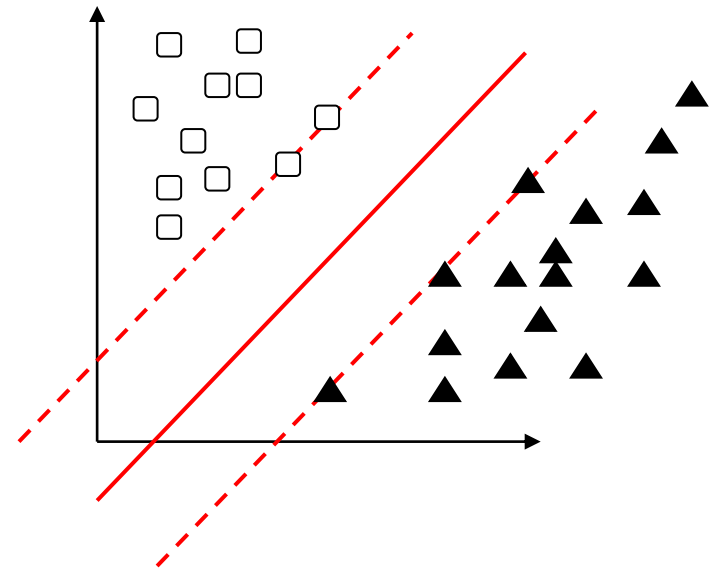

- SVM takes the positive and negative samples in each iteration and change the hyperplane in order to improve the classification.

- A database of 20000 contextual image patches is provided.
- For each method we extract feature vector of contextual images and add mean value and variance of contextual image to the feature vector.
- Our supervised classifier is a visual tool that in every iteration allows us to observe a number of samples which are placed on SVM surfaces in order to select positive and negative samples corresponding to one class.

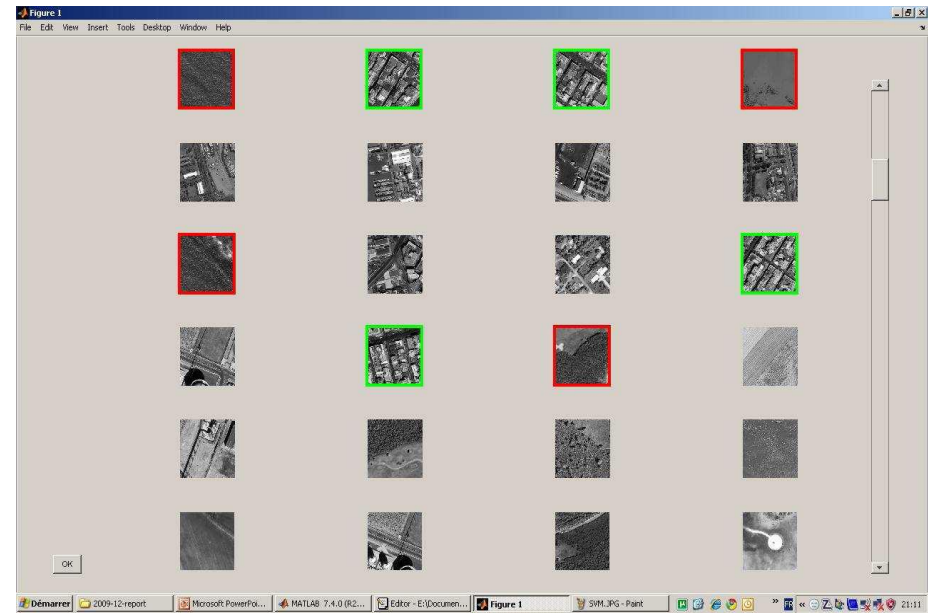

- Detecting one class is done during about 7-15 training iterations. We stop detecting a class when the samples shown by visual tool stay in a stable situation.

- We extracted 20 classes from different man-made and natural landscapes.

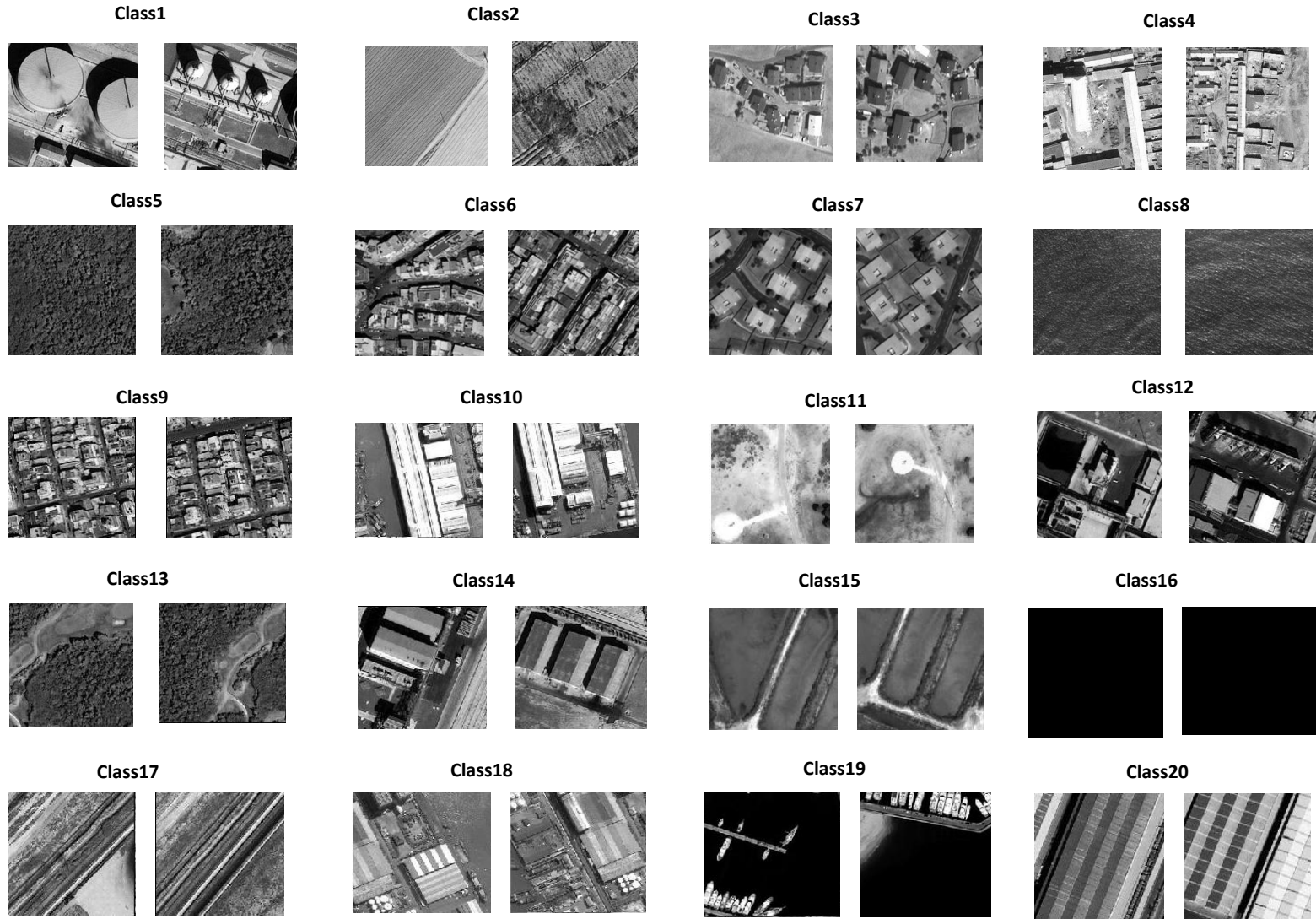

- Precision (red) is defined as the number of relevant samples retrieved by classification divided by the total number of samples retrieved by that classification.
- Recall (blue) is defined as the number of relevant samples retrieved by classification divided by the total number of existing relevant samples (which should have been retrieved) .

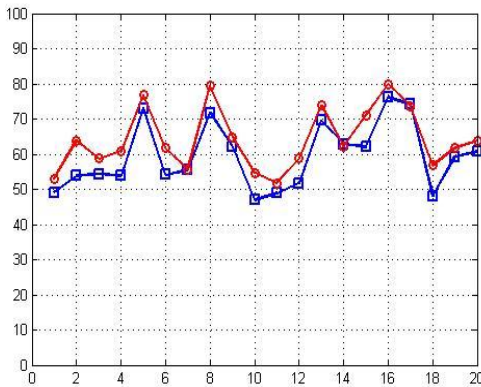

Gabor wavelet

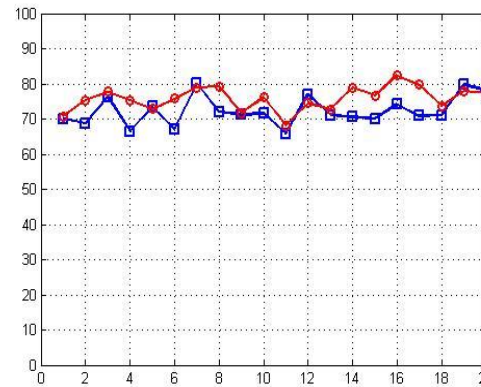

ICA

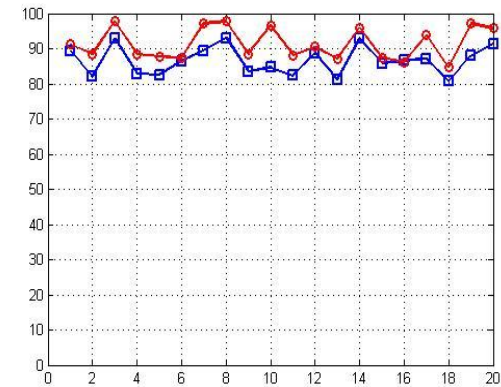

TICA

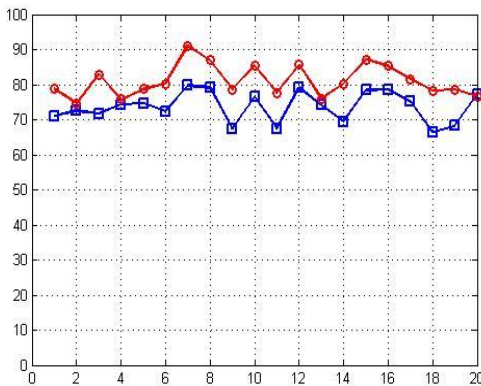

Bag of Words

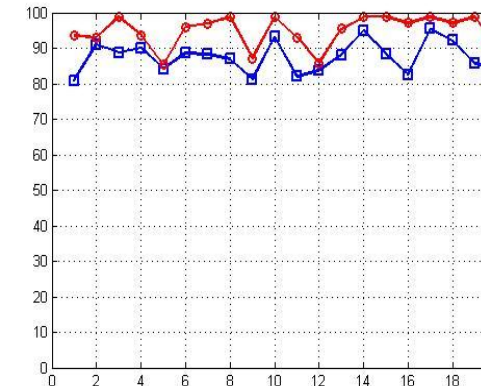

Lines inside basis vectors

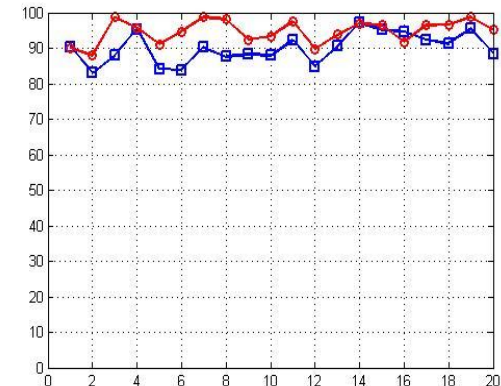

Lines inside the image

# Comparison of methods

- “Gabor ” don’t present a suitable result but they work an acceptable accuracy for natural classes.
- “TICA”, “Lines inside the basis vectors” and “lines inside the images” have the best results.
- “Gabor “, “ICA” and “TICA” are faster than other methods.
- “TICA”, “Lines inside the basis vectors” and “lines inside the images” have short feature vectors.

	<b>Average of precision and recall</b>	<b>Average of time for obtaining features</b>	<b>Length of feature vector</b>
<b>Gabor features</b>	P=64.14% R=59.41%	0.15 sec	27
<b>ICA features</b>	P=75.79% R=72.29%	0.15 sec	27
<b>TICA features</b>	P=91.39% R=86.57%	0.21 sec	11
<b>Bag of words features</b>	P=81.01% R=73.68%	0.82 sec	66
<b>Lines inside basis vectors</b>	P=94.87% R=87.54%	0.96 sec	13
<b>Lines inside images</b>	P=93.37% R=88.63%	0.59 sec	13



- Principles of Independent Component Analysis
- Scale and Dimensionality Behavior of ICA components for satellite images
- Feature extraction from ICA sources
- Middle level Topographic ICA features
- Feature extraction from ICA basis vectors: Bag of Words model
- Feature extraction from ICA basis vectors: Line and gradient properties
- Features based on line properties inside Images
- Supervised classification based on SVM
- **Conclusions and Perspectives**

- A methodology was presented to study the statistical nature of satellite images and extract their statistical signatures.
- Algorithms were developed for extracting features from image patches and defining descriptors.
- Evaluation of feature vectors shows good results for satellite images with about 1m resolution.
- Descriptors are placed between textural and local features.
- Descriptors are suitable for a variety of scenes, especially man-made landscapes characterization.
- TICA is the most efficient methods regarding to its results and its computation time and the length of descriptor.

- Descriptors can be developed and can be combined with other features extracted from other methods to improve their efficiency.
- Features extraction algorithms can be verified with the satellite images from other sensors and with other resolutions.
- Features extraction algorithms can be verified with other types of images ; Medical images, natural images, astronomy ,...
- Descriptors can be used for Image Information Mining and classification algorithms.
- Proposed features can be used for different applications such as urban area detection, Geographic Information System, image search engines, ...

**Thanks for your attention**